



GARDEN REACH SHIPBUILDERS & ENGINEERS LTD.

गार्डन रीच शिपबिल्डर्स एण्ड इंजीनियर्स लिमिटेड

(A GOVERNMENT OF INDIA UNDERTAKING) / (भारत सरकार का प्रतिष्ठान)

Address: 61, Garden Reach Road, Kolkata-700 024 61, गार्डन रीच रोड, कोलकाता-700 024

Phone/दूरभाषः(033) 2469-8140 to 8143, FAXफैक्सः (033) 2469-8144

Web siteवेबः www.grse.in, E-Mailई मेलः Gupta.Manoj@grse.co.in

CIN / सी आई एनः L35111WB1934GOI007891

NOTICE INVITING TENDER (NIT)

निविदा आमंत्रण सूचना

Garden Reach Shipbuilders & Engineers Limited, a **leading Warship Builders and Engineering Product Company**, invites interested, reputed, resourceful and financially solvent contractors to submit **single stage two-part bids (Part I- Techno-Commercial & Part II- Price)** through e-tendering mode for the work package as per following bid document.

NIT SLA No / निविदा संख्या:	SCC/NK/NIC/OT/CDO/Valves/019/ET-2018 DTD: 14-Oct-2023	
Job Title / कार्य का नाम	RE-SIZING / REFURBISHMENT OF VALVES	
SOR No:	GT61410014M/A Rev.03 dt. 10.07.23 (Annexure-1A)	
Tender issuing Dept. / बिभाग द्वारा जारी	Contract Cell (संविदा बिभाग)	
Cardinal Dates		
Date of Prebid Query Submission	19-Oct-2023	12:00 noon
Date of Prebid Meeting / बोलीपूर्व बैठक	20-Oct-2023	09:30 hrs
Commencement of Bid Submission	01-Nov-2023	15:00 hrs
Tender Submission Due Date निविदा जमा की अंतिम तिथी	06-Nov-2023	12:00 noon
Tender Opening Date (Part I) निविदा खुलने की तिथी	08-Nov-2023	14:30 hrs
Contact Persons:		
Query regarding SOTR / Drawing or other technical Terms	Mr. Manindra Mohan Chatteraj, Sr. Manager (CDO) E-mail: Chatteraj.M.M@grse.co.in Mobile no.: + 91-9163361896	

NIT TERMS & REQUIREMENTS

Sl. No.	Description	Reference	Requirement of NIT
1.	TENDER FEE	STAC	INR 500/- (Rupees Five hundred only)
2.	EARNEST MONEY DEPOSIT (EMD)	STAC	INR 8,00,000/- (Rupees Eight Lakh only)
3.	DETERMINATION OF L1	Article – 15	L1 bidder will be decided on TOTALITY BASIS excluding GST
4.	SECURITY DEPOSIT	Article – 22 (1)	5% of total order value (inclusive of taxes)
5.	PERFORMANCE GUARANTEE	Article – 22 (2)	10% of total executed order value (inclusive of taxes)
6.	LIQUIDATED DAMAGES	Article – 22 (9)	0.5% per week, Max. 5% of unexecuted job
7.	TECHNICAL ELIGIBILITY CRITERIA	Article -1 & Annexure-1A	As per Clause-2 & 3 of SOTR (Annexure-1A)



Sl. No.	Description	Reference	Requirement of NIT
8.	FINANCIAL ELIGIBILITY CRITERIA	Article -2	Average Annual financial turnover should be at least Rs. 120 Lakh during last 03 financial years ending on 31 st March 2023.
9.	VENDORS ON TENDER HOLIDAY / BLACKLISTED VENDORS	Article – 3	Submission of the self-certification document as per relevant format is mandatory. On non-submission of the declaration the bidder may be treated as non-responsive, and their offer may be rejected.
10.	OFFER VALIDITY	Article – 4	180 days
11.	BOQ	Article-6	As detailed at Article-6
12.	TENURE OF CONTRACT / COMPLETION PERIOD	Article – 8	04 (Four) months from date of PO / LOA
13.	MOBILIZATION PERIOD	Article – 9(a)	The successful bidder is required to give notice to GRSE 3 days in advance before mobilisation of resources for collecting the surplus valves from GRSE site.
14.	JOB COMPLETION SCHEDULE	Article – 9(c)	04 (Four) months from date of PO / LOA Ref Clause – 6(viii) of SOTR (Annexure-1A)
15.	GUARANTEE & WARRANTY / DEFECT LIABILITY PERIOD	Article – 10	The materials are to be guaranteed /warranted for satisfactory performance for the period of 12 Months from the date of commissioning of the respective ship on which the equipment/materials/items are installed or 36 months from the receipt of last consignment of equipment/materials/items at GRSE whichever is earlier against improper design, defective materials and faulty workmanship. Ref Clause – 6(vii) of SOTR (Annexure-1A)
16.	ESCALATION	Article – 12	Not Applicable
17.	AWARDING JOBS TO MULTIPLE BIDDERS	Article – 16	Not Applicable
18.	INTEGRITY PACT & INDEPENDENT EXTERNAL MONITORS (IEM)	Article – 18	Applicable Submission of INTEGRITY PACT complying to Article-18 & 25 and ANNEXURE-11 of NIT is MANDATORY.
19.	PAYMENT TERMS	Article – 22 (3)	Terms mentioned at Article-22(3) shall prevail over SOTR. 1. 90% (Ninety percent) of the value of work done will be paid progressively against R/A bill subject to completion of work for each line item. 2. 10% (Ten percent) of the value of work done shall be held as Performance Guarantee. Release shall be as per Article – 22(3.3).
20.	QUALITY ASSURANCE AUTHORITY / INSPECTION AUTHORITY	Article – 22	Inspection shall be done by GRSE / GRSE nominated agency as per approved QAP. For further details refer Clause -6(iii), 6(iv), 6(v) & 10 and Annexure-V of SOTR.
21.	WORK DONE CERTIFICATE AUTHORITY	Article – 22	In charge FOJ Pipe Shop / his authorised representatives.
22.	BILL CERTIFYING AUTHORITY	Article – 22	AGM(Eng.)/FOJ / his authorised representatives.
23.	NON-DISCLOSURE AGREEMENT	Annexure-12	APPLICABLE



Sl. No.	Description	Reference	Requirement of NIT
24.	COLLECTION OF RAW MATERIAL AND DELIVERY OF COMPLETE MATERIALS	Article – 22	<p>➤ Applicable</p> <p>➤ Special Terms for this Tender</p> <p>The Successful Bidder has to submit Material Guarantee Deposit in form of DD / Bank Guarantee (as per GRSE format), prior to taking out of the existing valves from GRSE premises, amounting to the value as follows:</p> <ul style="list-style-type: none">• Amount of Material Guarantee Deposit = $(0.8 \times \text{Gross Weight of Material}) \times (\text{Rate of Gun Metal Scrap as notified by Bombay Metal Exchange as on date of weighment of the collected material})$.• For Bombay Metal Exchange Rates refer website www.bme.in. <p>Indemnity Bond shall not be accepted.</p>
25.	MATERIAL RECONCILIATION	Article – 22	<p>➤ Applicable</p> <p>➤ Special Terms for this Tender</p> <p>The gross weight of the Gun Metal parts of resized / refurbished valves to be recorded in presence of GRSE Inspection Authority.</p> <p>In case, the total weight (W_r) of such resized / refurbished parts is less than 80% of the Gross Weight of material collected (W_c), the vendor shall be required to reimburse on account of material GRSE as per follows:</p> <p>Amount of Reimbursement = $[(0.8 \times W_c) - W_r] \times (\text{Rate of Gun Metal Scrap as notified by Bombay Metal Exchange as on date of weighment of the collected material})$.</p> <p>However, it is to be noted that no additional payment shall be made by GRSE if W_r exceeds 80% of W_c.</p>

Sr. Manager (Contract) / वरिष्ठ प्रबन्धक (संबिदा)
Garden Reach Shipbuilders & Engineers Limited
61, Garden Reach Road, Kolkata – 700024.
email: Kar.Nilanjan@grse.co.in



Contents

NOTICE INVITING TENDER (NIT)	1
INTRODUCTION	5
ARTICLE/अनुच्छेद 1. TECHNICAL ELIGIBILITY CRITERIA तकनीकी मापदंड	5
ARTICLE/अनुच्छेद 2. FINANCIAL ELIGIBILITY CRITERIA वित्तीय मापदंड	5
ARTICLE/अनुच्छेद 3. VENDORS ON TENDER HOLIDAY / BLACKLISTED VENDORS	5
ARTICLE/अनुच्छेद 4. OFFER VALIDITY प्रस्ताव की वैधता	5
ARTICLE/अनुच्छेद 5. OPENING OF BIDS निविदा खुलना	5
ARTICLE/अनुच्छेद 6. BOQ बी ओ क्यू	5
ARTICLE/अनुच्छेद 7. JOB EXECUTION कार्य निष्पादन	6
ARTICLE/अनुच्छेद 8. TENURE OF CONTRACT	6
ARTICLE/अनुच्छेद 9. JOB EXECUTION SCHEDULE कार्य निष्पादन सूची	6
ARTICLE/अनुच्छेद 10. GUARANTEE & WARRANTY गारंटी एवं वारंटी	6
ARTICLE/अनुच्छेद 11. PRICE मूल्य	6
ARTICLE/अनुच्छेद 12. ESCALATION मूल्य वृद्धि	6
ARTICLE/अनुच्छेद 13. UNREASONABLE QUOTES अतर्कसंगत भाव	6
ARTICLE/अनुच्छेद 14. CONDITIONAL OFFER सशर्त प्रस्ताव	7
ARTICLE/अनुच्छेद 15. DETERMINATION OF L1 एल-1 का चयन	7
ARTICLE/अनुच्छेद 16. AWARDING JOBS TO MULTIPLE BIDDERS बहुल बिडर के लिए ठेका कार्य	7
ARTICLE/अनुच्छेद 18. Integrity Pact & Independent External Monitors (IEM): (Applicable for the Contract value more than Rs. 2.0 Cr.)	7
ARTICLE/अनुच्छेद 19. INSTRUCTION TO THE BIDDERS बिडर हेतु अनुदेश	8
ARTICLE/अनुच्छेद 20. e-BID INSTRUCTION ई बिड के अनुदेश	9
ARTICLE/अनुच्छेद 21. BID REJECTION CRITERIA बिड अस्वीकृति के मापदंड	9
ARTICLE/अनुच्छेद 22. POST AWARD APPLICABLE CLAUSES ठेका जारी करने के पश्चात लागू उपधारा	10
ARTICLE/अनुच्छेद 23. ANNEXURES FORMING PART OF THIS e-TENDER ई-निविदा की संलग्नक प्रपत्र	11
ARTICLE/अनुच्छेद 24. DOCUMENTS TO BE UPLOADED अपलोड हेतु दस्तावेज	12
ARTICLE/अनुच्छेद 25. DOCUMENTS IN PHYSICAL FORM TO SUBMIT वास्तविक प्रपत्र जो जमा करने हैं	13
ARTICLE/अनुच्छेद 26. SUBMISSION OF BID बिड की पेशी	14
ARTICLE/अनुच्छेद 27. PRE-BID MEETING बोलीपूर्व बैठक	14
ANNEXURE-1A: STATEMENT OF TECHNICAL REQUIREMENTS (SoTR) & DRAWINGS	15
ANNEXURE-1B: BILL OF QUANTITIES	49
ANNEXURE 1C: PAYMENT TERMS	51
ANNEXURE -2: STANDARD TERMS & CONDITIONS (STAC)	52
ANNEXURE -2: STANDARD TERMS & CONDITIONS (STAC) मानक निबंधन और शर्तें (एसटीएसी)	52
ANNEXURE – 3: EXECUTED RELEVANT JOBS for TECHNICAL ELIGIBILITY	69
ANNEXURE – 4: FORMAT for FINANCIAL ELIGIBILITY	70
ANNEXURE-5: FORMAT OF SELF-CERTIFICATION FOR DECLARATION REGARDING BLACKLISTING/ TENDER HOLIDAY	71
ANNEXURE-6: FORMAT FOR DISCLOSURE BY CONTRACTOR OF EXISTING WORK	72
ANNEXURE-7: FORMAT FOR DISCLOSURE BY CONTRACTOR OF PROPOSED EXECUTION / DEPLOYMENT PLAN OF THIS TENDERED JOB	73
ANNEXURE-8: CONFIRMATION BY BIDDER & CHECKLIST FOR BID SUBMISSION	74
ANNEXURE-9: CHECK LIST FOR BILL SUBMISSION - for Service Contracts	75
ANNEXURE-11: INTEGRITY PACT	76
ANNEXURE-12: NON-DISCLOSURE AGREEMENT	80



INTRODUCTION

Garden Reach Shipbuilders & Engineers Limited, a leading Warship Builders and Engineering Product Company, invites interested, reputed, resourceful and financially solvent contractors to submit **Single Stage two-part bids (Part I: Techno-Commercial & Part II- Price Bid)** through e-tendering mode for the work of **“RE-SIZING / REFURBISHMENT OF VALVES”**. Detailed Scope of work is mentioned in SOTR (Annexure-1A).

ARTICLE/अनुच्छेद 1. TECHNICAL ELIGIBILITY CRITERIA तकनीकी मापदंड

- i. Bidder should comply to Eligibility Criteria mentioned in SOTRs. **(Annexure-1A)**.
- ii. Format for Technical Eligibility Criteria in this regard has been attached to this document as **Annexure - 3**. The format must be filled up and to be uploaded with the Techno-commercial Bid.

ARTICLE/अनुच्छेद 2. FINANCIAL ELIGIBILITY CRITERIA वित्तीय मापदंड

- i. Bidder's Average Audited Annual financial turnover during last 03 financial years should be at least the amount as specified at NIT Terms & Requirements. Audited Annual Statement for the relevant last three (03) years is to be provided while submitting the bid.
- ii. Requisite formats attached with NIT as **Annexure 4** to be filled up in support of above financial eligibility criteria.

ARTICLE/अनुच्छेद 3. VENDORS ON TENDER HOLIDAY / BLACKLISTED VENDORS

- i. The bidder should give self-certification (as per **Annexure - 5**) that they have neither been Blacklisted nor have received any tender holiday from any PSUs/Central & State Govt. Organizations or any other Government / Quasi Government Organizations during last 03 (three) years ending on the date of submission of the Tended by the bidder. The bidder has to submit self-certification for the same along with the techno-commercial offer. GRSE reserves the right to independently verify the same. In case violation of declaration is detected at any stage of tender process and during currency of contract, the order will be terminated.
- ii. If any bidder has been black listed by any PSUs/Central & State Govt. Organizations or any other Government / Quasi Government Organizations, then the bidder is not eligible to participate in this tender. If any discrepancy is detected at any stage of the tender, then the offer submitted by the bidder / contract awarded to the bidder will be cancelled and EMD/SD shall be forfeited and appropriate action will be taken in accordance with the vendor policy of GRSE.
- iii. If any bidder has been put on Tender Holiday by any PSUs/Central & State Govt. Organizations or any other Government / Quasi Government Organizations, then this fact must be clearly stated and it may not necessarily be a cause for disqualifying them.
- iv. In case of non-submission of the self-certification document as per relevant format referred at SI- (i) above, the bidder will be treated as non-responsive and their offer will be rejected.

ARTICLE/अनुच्छेद 4. OFFER VALIDITY प्रस्ताव की वैधता

- i. Offer should be valid for period as stipulated in NIT Terms & Requirements from the date of opening of Part-I bid i.e. Techno-commercial bid. Under exceptional circumstances GRSE may request for extension of price validity, beyond the stipulated period against valid reason.

ARTICLE/अनुच्छेद 5. OPENING OF BIDS निविदा खुलना

Part I (techno-commercial) bid will be opened on the date declared in NIT.

Part II bid will be opened post techno-commercial evaluation by GRSE. Price bid of only those who qualify techno-commercially will be opened. Opening date of Price Bid will be intimated accordingly to all qualified bidders. Disqualified bidders, either during technical assessment or commercial discussion will also be intimated about their non-consideration for farther processing.

ARTICLE/अनुच्छेद 6. BOQ बी ओ क्यू

- (a) BOQ for the work is detailed at **Annexure-1B**.

Unpriced copy of the Price breakup indicating the GST SAC/HSN Code & GST percentage is to be uploaded alongwith the Techno-commercial offer (Part-I). The bid shall not be considered if Price is indicated in any part of Techno-commercial offer (Part-I).



ARTICLE/अनुच्छेद 7. JOB EXECUTION कार्य निष्पादन

Job is to be carried out strictly as per SOTR and GRSE requirement and in case of doubt, instructions of the officer-in-charge of GRSE/ their authorised representative is to be followed.

ARTICLE/अनुच्छेद 8. TENURE OF CONTRACT

The tenure of the contract shall be as specified in the NIT Terms & Requirements.

ARTICLE/अनुच्छेद 9. JOB EXECUTION SCHEDULE कार्य निष्पादन सूची

- (a) **Mobilization Period / लामबंदी अवधी** shall be equal to number of days (as specified in the NIT Terms & Requirements) from date of LOA/PO.
- (b) **Job Starting Date / कार्य आरम्भ तिथी** Job is to be started immediately after mobilization as per direction of WDC Authority / Bill Certifying Authority / their authorized representatives.
- (c) **Job Completion Schedule / कार्य समाप्ती तिथी:** -The job is required to be completed within time limit as specified at NIT Terms & Requirements.

ARTICLE/अनुच्छेद 10. GUARANTEE & WARRANTY गारंटी एवं वारंटी

Duration of Guarantee Period / Defect Liability Period shall be as per requirement mentioned at NIT Terms & Requirements and shall commence from the date mentioned in the Completion Certificate.

Guarantee Period / Defect Liability Period shall be deemed to be over on completion of the specified duration subject to successful and satisfactory liquidation of defects notified within the pendency of the Guarantee Period / Defect Liability Period.

In case of pending unresolved defects, the Guarantee Period / Defect Liability Period shall stand automatically extended till satisfactory liquidation of defects.

ARTICLE/अनुच्छेद 11. PRICE मूल

- (a) The rates QUOTED/ACCEPTED by the bidder, shall be final and will remain **firm and fixed for the entire contractual period or till completion of ordered work.**
- (b) The quoted price should also include all statutory cost as mentioned/ indicated in SOTR.
- (c) GST is to be indicated separately in the Price Breakup.

ARTICLE/अनुच्छेद 12. ESCALATION मूल्य वृद्धि

NO ESCALATION of price during the contractual period and/or till completion of complete work (except change in GST Rate, if notified by Competent Authority) shall be applicable.

ARTICLE/अनुच्छेद 13. UNREASONABLE QUOTES अतर्कसंगत भाव

- (a) In case the price of L-1 Bidder is found to quote unreasonably low and/or express desires to withdraw from the tender then such bid will be cancelled and EMD will be forfeited and punitive action will be taken in line with the provision as per GRSE Vendor policy.
- (b) However, in case the L1 Bidder agrees to take-up the job with such unreasonable low quote, lower by 30% or more than estimate and also if the difference in price between L1 & L2 is 30% or more, then the quoted price to be analyzed w.r.t. tender requirement and if the L1 bidder fails to justify their quoted rate, the obtained L1 quote may be liable for rejection.
- (c) If justification is acceptable to GRSE, then Bidder have to submit a declaration to execute the job till satisfactory completion of entire contract. In case of breach of contract, GRSE shall reserve the right to impose Tender Holiday for a period of at least 03 years.



ARTICLE/अनुच्छेद 14. CONDITIONAL OFFER सशर्त प्रस्ताव

Conditional offers w.r.t. SOTR (Annexure 1) will not be accepted. However, in case the bidder wishes to deviate from any/ some commercial Terms & conditions, then separate deviation statement has to be uploaded along with Part-I bid.

However, GRSE reserves the right to accept / reject the deviations / bid with deviations after giving reasonable opportunity to the Bidder.

If the deviation is acceptable to GRSE, then suitable loading factor for such deviation on the price quoted by the bidder will be formulated during technical/commercial negotiation and the factor will be loaded on the price quoted by the bidder for determination of L1 price.

ARTICLE/अनुच्छेद 15. DETERMINATION OF L1 एल-1 का चयन

- (a) **L1 bidder will be decided as per criteria mentioned at SI-3 of NIT Terms & Requirements.**
- (b) However, in case of loading the price due to any deviation against the tender, GRSE will evaluate L1 bidder offline, considering suitable loading factor for such deviation on the quoted price as mentioned in Article-14 above.

ARTICLE/अनुच्छेद 16. AWARDING JOBS TO MULTIPLE BIDDERS बहुल बिडर के लिए ठेका कार्य

- (a) Separate bidder may be engaged against each line item mentioned in BOQ based on L1 determination (as mentioned at Article-15 above) as specified at **SI-18 of NIT Terms & Requirements.**
- (b) GRSE wishes to engage multiple bidders for the tendered work subject to the bidders accepting the rate quoted / agreed by L1 Bidder. The ratio of distribution shall be as indicated in **SI-18 of NIT Terms & Requirements.**

ARTICLE/अनुच्छेद 17. MICRO & SMALL ENTERPRISES सूख्छम एवं छोटे उद्योग

- a) The 'Public Procurement Policy for Micro & Small Enterprises (MSEs) Order, 2012 and subsequent amendments / guidelines / press publications / circulars to the Order, as issued by the Ministry of MSME, shall be applicable as on the date of opening of the price bids.
- b) The bidders are advised to check the website of the Ministry of MSME for details of the amendments / circulars issued by the Ministry of MSME.
- c) Class A and B items are to be considered as non-divisible within the same class of ships and tender is to be awarded on a single bidder on totality basis unless there is any specific clause in the tender enquiry to indicate divisibility of the tendered quantity.

ARTICLE/अनुच्छेद 18. Integrity Pact & Independent External Monitors (IEM): (Applicable for the Contract value more than Rs. 2.0 Cr.)

- (a) **Integrity Pact (समग्रता अनुबंध)** pact essentially envisages the agreement between prospective vendors /Bidders & buyers committing the person/officials of both the parties not to exercise any corrupt influence on any aspects of the contract. Only those vendors/bidders who enter into such an integrity pact with the buyer would be competent to participate in the bid. The format of integrity Pact is enclosed with tender documents. Refer Annexure - 10. The "Integrity pact on Govt. issued Stamp paper of Rs. 100 duly filled as per enclosed format to be submitted in original. Bidders to ensure that every page of IP is ink signed with company seal/stamp in every page. [Please refer guideline for IP in STAC (SI.-1) in GRSE website]
- (b) Either or both of the following Independent External Monitors will have the power to access the entire project document and examine any complaints received by him. In case of any change in IEMs, it will be informed accordingly.
- (c) The communication details of the IEMs are as follows: -

Shri Bam Bahadur Singh, Height-7; Flat No.1802, Uniworld City, New Town, Rajarhat, Kolkata-700160 Email: bbsinghbeml@gmail.com	Shri Pidatala Sridhar, IRS (Retd.) Flat 2C, Kanaka Lakshmi Apartments 3-6-467 & 468 Street Number-6, Himayatnagar, Hyderabad-500029, Email: sridharpidatala@gmail.com
--	--



ARTICLE/अनुच्छेद 19. INSTRUCTION TO THE BIDDERS बिडर हेतु अनुदेश

- i. Before submitting a bid, bidders are expected to examine the Bid Documents carefully. If they desire, **may visit the work front**, fully inform themselves of existing conditions and limitations including all items described in the Bid Documents. No consideration will be granted for any alleged misunderstanding or the materials to be furnished, work to be performed or actual considerations to complete all work and comply with conditions specified in the Bid Document.
- ii. Any qualified deficiency, errors, discrepancies, omissions, ambiguities or conflicts in the Bid Documents, or there be any doubts as to the meaning of a provision or requirement, the same shall immediately brought to notice of GRSE Tendering Dept. in writing not less than 07 days prior to bid closing date.
- iii. It is understood that in receiving this bid, GRSE assumes no obligation to enter into a contract for the WORK covered by this bid request. GRSE reserves the right to reject any and all unqualified proposals or waive irregularities therein. GRSE reserves the right to evaluate each and every proposal and accept the whole or any part of the tender and the Tenderer shall be bound to perform the same at the rates quoted.

GRSE also reserves the right to reject any and all bids and accept the bid, which in its opinion, appears to be most advantageous to GRSE. Receipt and review of this Bid Request constitutes an agreement of confidentiality between GRSE and each of the contracting Firms preparing its Bid. GRSE reserves the right to change the form of this request to Bids, or make clarifications thereto, within a reasonable time before date of submission of Bids.
- iv. General Contractors assume all safety related responsibilities for the site and will furnish and maintain its own safety program for itself and its subcontractors. Contractor are bound to comply with all applicable Environmental, Health & Safety rules, regulations, policies, procedures and guidelines when performing work in the facility or site.
- v. Bidders objecting on any grounds to any bid specification or legal requirements imposed by these bidding documents shall provide written notice to GRSE within 10 calendar day from the day bid document was made available to public. Failure of a bidder to object in the manner set forth in this paragraph shall constitute and irrevocable waiver of any such objection.
- vi. Job is to be carried out as per SOTR and instruction of the Engineer in-charge.
- vii. Any Drawings or technical information attached / provided with this NIT is the Intellectual Property of the Company and will be governed by the specific Acts applicable thereto.
- viii. Post submission of Tender, such drawings and technical information are to be physically returned. Also, all soft copies are to be destroyed and a self-certification to be submitted during CNC, failing which the processing of bid will not be taken further.
- ix. Contractors are responsible to clean up the area of work from all sorts of debris every 3 days. In case of non-compliance to the same, GRSE reserves the right to perform the cleaning activity and charge cost for the same on the contractor with additional penalty of Rs 5000/- per instance.
- x. Bidder has to declare, in what capacity he is participating in the tender viz PSU, Limited Co, Pvt. Ltd. Co., Sole Proprietorship Organization, Partnership firm, Joint Venture / Consortium [Ref. STAC (Annexure - 2), Clause: 10], etc. Supporting documents (scanned copy) confirming such status to be uploaded as attachment to Part-I bid.
- xi. A Bidder is allowed to submit only one Bid under any capacity / status.
- xii. Difficulty in submitting the bid:
 - a) In case of any query / difficulty in understanding of SOTR or other technical Terms the same may be got clarified from SOTR authority prior submission of offer.
 - b) Any query/difficulty in understanding of Commercial Terms may be got clarified from Mr. Nilanjan Kar, Sr. Manager (Contract), GRSE (Main Unit) e-mail: Kar.Nilanjan@grse.co.in Mobile no. +91-8584888194.
- xiii. **E-mail Address of Vendor for communication संचार हेतू ई. मेल पत:** Vendor has to provide e-mail address to enable faster communication.



ARTICLE/अनुच्छेद 20. e-BID INSTRUCTION ई बिड के अनुदेश

- a) Bidders can view / download Part-I (Techno-Commercial) bid documents along with all attachments on portal <https://eprocuregrse.co.in>. Bidders need to fill up the downloaded documents including the Acceptance Matrices and Declarations as per instruction and upload the same during bid submission as per Bid criteria. Non-acceptance of any techno-commercial criteria is discouraged.
- b) Detailed price breakup as per BoQ is to be uploaded with price offer (Part-II). No other attachment to the price bid except as mentioned will be reckoned.
- c) **If price is indicated in any document pertaining to Part-I of the bid the Offer shall be summarily rejected.**
- d) In case the bidder does not quote his rate for any item(s), it will be presumed that the bidder has included the cost of that/those item(s) in the rates of other items and the rate for such item(s) shall be considered as Zero (0) and the tender shall be evaluated accordingly and the work need to be executed by the successful bidder accordingly.
- e) The amendments / clarifications to the bid document, if any, will be posted on portal only.
- f) It will be the bidder's responsibility to check the status of their Bid on-line regularly after the opening of bid till award of Contract.

g) AMENDMENT OF TENDER DOCUMENT

- (i) Before the deadline for submission of tenders, the Tender Document may be modified by GRSE Ltd. by issue of addenda/corrigendum. Issue of addenda / corrigenda will however be stopped 7 days prior to the deadline for submission of tenders as finally stipulated.
- (ii) Addendum/corrigendum, if any, will be hosted on website / e procurement portal and shall become a part of the tender document. All Tenderers are advised to see the website for addendum/ corrigendum to the tender document which may be uploaded up to 7 days prior to the deadline for submission of Tender as finally stipulated.
- (iii) To give prospective Tenderers reasonable time in which to take the addenda/ corrigenda into account in preparing their tenders, extension of the deadline for submission of tenders may be given as considered necessary by GRSE.

h) PREVALANCE OF VERSION / संस्करण की व्यापकता:

In case of any discrepancy between English and Hindi version **the English Version shall prevail.** / अंग्रेजी और हिंदी संस्करण के बीच किसी भी विसंगति के मामले में अंग्रेजी संस्करण मान्य होगा।

ARTICLE/अनुच्छेद 21. BID REJECTION CRITERIA बिड अस्वीकृति के मापदंड

Following bid rejection criteria may render the bids liable for rejection:

- i. Bidder indicating price offer in any form in the Part-I bid i.e techno-commercial bid.
- ii. Bidder's failure to furnish sufficient or complete details for evaluation of the bids within the given period which may range in between two to three weeks depending on the deficiencies noticed in the drawings / technical data which shall not however conflict with validity period.
- iii. Incomplete / misleading / ambiguous bid in the considered opinion of the Technical Negotiation Committee (TNC) of GRSE.
- iv. Bid with technical requirements and/or terms not acceptable to GRSE / Customers / External agency nominated, as applicable.
- v. Bid received without qualification documents, where required as per the tender.
- vi. Bid not meeting the pre-qualification parameters / criteria stipulated in the Tender Enquiry.
- vii. Bid with validity expiry date shorter than that specified in the Tender Enquiry.
- viii. EMD validity period is shorter than Bid Validity Period / as specified in the tender enquiry.
- ix. Bidders who have not agreed for the fixed price till the validity of the tender or have quoted the variable price.
- x. Bidder not agreeing for furnishing of the required Security Deposit (SD).
- xi. Bidders not submitting Original instrument of EMD within 05 days from opening of Part I bid.



- xii. Bidder not submitting Integrity Pact as per requirement of the tender and in reference to ARTICLE/अनुच्छेद 18. of NIT.
- xiii. Bidder submitted false / incorrect declaration and/or documents etc.

ARTICLE/अनुच्छेद 22. POST AWARD APPLICABLE CLAUSES ठेका जारी करने के पश्चात लागू उपधारा

1. **Security Deposit प्रतिभूति जमा-** non-interest-bearing security deposit amounting to percentage of total individual order value (inclusive of taxes) as specified at NIT Terms & Requirements is to be deposited in the manner elaborated in STAC (Annexure - 2).

Security Deposit shall be released on issue of job completion certificate by WDC Authority and submission of PBG (if applicable).

2. **Performance Guarantee:** Non-interest-bearing Performance Guarantee deposit amounting to percentage of total executed order value (inclusive of taxes) as specified at NIT Terms & Requirements is to be deposited in the manner elaborated in STAC. The same shall be released after successful completion of Guarantee Period / Defect Liability Period and satisfactory liquidation of defects.

3. **Payment Terms भुगतान की शर्तें:**

3.1 The contractor shall submit the R/A bills in triplicate along with all necessary / required supporting documents, measurement sheet etc.

3.2 **Percentage** of the value of actual work done as specified at NIT Terms & Requirements will be paid progressively against R/A bill at a frequency of once every month during construction. The amount paid at every month shall be evaluated on the basis of actual completed works done during the previous month, against the BOQ item and Unit Rates, on certification of quantum and quality of work by Engineer / Engineer's Representative.

3.3 **Remaining Percentage** of the certified value of work shall be released on: -

Completion of the Guarantee period / defect liability period subject to satisfactory liquidation of defects duly certified by Bill Certifying Authority.

OR

Submission of performance Bank Guarantee of equivalent amount valid till expiry of Guarantee period.

For release of this remaining percentage i.e. retention money (if any) either after guarantee period or on submission of PBG; work done certificate shall not be required. While releasing PBG after expiry of guarantee period, the PBG release application to be submitted to Contract Cell duly certified by Bill Certifying Authority.

4. **Work Done Certificate (W.D.C.) कार्य पूर्ति प्रमाण-पत्र (डबल्यू.डी.सी)**

Work Done Certificate will be issued by the Quality Assurance Authority OR his Nominated Officer based on clear inspection report as applicable.

W.D.C. is to include whether work has been completed as per delivery schedule or with delay [in days/weeks specified therein]. Any recovery towards usage of GRSE resources is also to be indicated.

5. **Bill Certifying Authority बिल प्रमाणन प्राधीकर:**

As mentioned at NIT Terms & Requirements.

6. **Bill Submission बिल प्रस्तुति:**

On obtaining WDC, bills to be raised as Progressive RA Bills. Bills are to be submitted along with supporting documents (Work Done Certificate etc.) at the Bill Receiving Counters located at the respective units of Company. Bill is to be submitted (in 03 copies) in sealed envelope super-scribing on the envelope the Purchase Order No., Vendor code, Bill / Invoice No., Name of person /employee to whom bill is addressed, for processing. The Name of the person to be mentioned on sealed envelope will be the Bill certifying officer.

Note: Transaction fee of Rs. 500.00 for first return & Rs. 1000.00 for subsequent return of bill with inappropriate documents will be charged



7. **Collection of Raw Material and Delivery of Complete materials (अनिर्मित सामग्री संग्रह एवं परिवर्तित सम्पूर्ण सामग्री की सुपुर्दगी)**
- (a) Raw materials will be required to be collected from GRSE against submission of Material Guarantee Deposit on form of Demand Draft / Bank Guarantee (as per GRSE format) amounting to value as specified at **NIT Terms & Conditions** OR the equivalent value of material as that will remain in the custody of the firm during the execution of the work ONLY in case of materials taken outside GRSE premises. Transportation of materials from GRSE to sub-contractor's premises and transportation of finished materials from Sub-contractor's premises up to GRSE are the responsibility of the contractor.
- ~~(b) Indemnity Bond affixing the Common Seal from the registered sub-contractors can be accepted but it should be backed by Insurance Coverage with GRSE as the beneficiary on case-to-case basis with due approval of the management. GRSE registered vendor who are interested to submit Indemnity Bond backed by Insurance coverage should indicate clearly in their offer.~~
8. **Material Reconciliation Statement (MRS) (सामग्री मिलान)**
- Vendors are to furnish the material reconciliation statement (running MRS) for all free issue materials, ONLY in case of materials taken outside GRSE premises against each consignment immediately on delivery of the same but not later than 30 days of delivery, showing details of raw materials received and material returned or as specified in at **NIT Terms & Conditions**. Any excess consumption of material on account of wastage / damage / re-work attributable to the Contractor, shall be liability of the Contractor and shall be recovered from the receivables of the Contractor from GRSE or otherwise.
- In case received material is less than issued material the cost of the material not received shall be recovered from the Contractor as per terms specified at **NIT Terms & Conditions**.
- The MRS should be submitted with documentary evidence of material issued & returned duly accepted by competent authority of GRSE and as per the GRSE format and filled up check list for MRS.
9. **Liquidated Damages / Penalty**
- The vendor will be liable to pay minimum Liquidated Damages @ ½ % per week or part thereof on the undelivered work subject to a maximum of 5 % of the value of the order for delayed part. The amount of L.D. may be adjusted or set-off against any sum payable to the Contractor under this or any other Contract with GRSE Ltd.
10. **Risk Purchase जोखिम खरीद**
- In case the progress of work is not satisfactory and the contractor fails to maintain the schedule, GRSE reserves the right to get the work done by alternative source at the risk and cost of sub-contractor.
- GRSE shall be at liberty to purchase/obtain the service from the alternative source as it deems fit, to make good such default and or in the event of the contract being terminated, the balance of the remaining service to be delivered there under. Any excess over the job price / service rates, paid and incurred by GRSE, as the case may be, over the contract price shall be recoverable from the firm. To make good the recoverable excess amount paid, GRSE shall be at liberty to invoke Bank Guarantee and/or with other available dues of the firm.
11. **Time of completion**
- Time of completion has to be considered as essence of the contract and cannot be extended for any reason whatsoever. However, in an unlikely situation beyond the control of the contractor, application for extension of due time shall be submitted by the Contractor, 01 Month in advance with proper justification duly endorsed by Engineer In-charge / PL of GRSE with commensurate recording of events in the "Hindrance Register". Please note LD will be levied for the unexecuted portion for such time extension.
12. **Contractor's Safety Personnel (संविदाकार के बचाव कर्मचारी)**
- One fully specialist and certified Safety Personnel has to be posted at the site during progress of work. The responsibility of the safety personnel is to supervise and monitor the site safety obligations of all work places and to comply all laid down Fire & Safety Rules of GRSE. He also ensures all workmen working under the sub-contractor at site are made aware of and comply with all the safety norms.

ARTICLE/अनुच्छेद 23. ANNEXURES FORMING PART OF THIS e-TENDER ई-निविदा की संलग्नक प्रपत्र

Please find all enclosures as indicated below in GRSE website by clicking the link <http://www.grse.in/index.php/tender.html> and then click Enclosure Related to tenders of Sub-Contracting Activities



Annexure/ संलग्नक	Description /
1.	A. Statement of Technical Requirement (SOTR) & Drawings B. Bill of Quantities (BOQ) C. Payment Terms
2.	GRSE Standard Terms and Conditions (STAC)
3.	Format for Technical Eligibility Criteria
4.	Format for Financial Eligibility Criteria
5.	Self-Certification for Blacklisting / Tender Holiday
6.	Format for – Disclosure by Contractor of existing work load
7.	Format for – Disclosure by Contractor of proposed execution / deployment plan of this tendered job
8.	Confirmation by Bidder & Checklist for Bid Submission
9.	Check List for Bill Submission – For Service Contracts
10.	Format for - Integrity Pact To be submitted in Non-Judicial stamp paper of value not less than Rs.100/-.
11.	Format for – Non-Disclosure Agreement (please refer www.grse.in →Tender→Enclosures Related to tenders of Sub-Contracting Activities)
12.	Format for – Bank Guarantee Format for EMD (please refer www.grse.in →Tender→Enclosures Related to tenders of Sub-Contracting Activities)
13.	Fire & Safety Guidelines (please refer www.grse.in →Tender→Enclosures Related to tenders of Sub-Contracting Activities)
14.	Special condition of contract (please refer www.grse.in →Tender→Enclosures Related to tenders of Sub-Contracting Activities)
15.	Contractors Responsibility (please refer www.grse.in →Tender→Enclosures Related to tenders of Sub-Contracting Activities)
16.	General Requirement (please refer www.grse.in →Tender→Enclosures Related to tenders of Sub-Contracting Activities)
17.	Check List for Bill submission (please refer www.grse.in →Tender→Enclosures Related to tenders of Sub-Contracting Activities)
18.	PF, ESI declaration form (please refer www.grse.in →Tender→Enclosures Related to tenders of Sub-Contracting Activities)
19.	Format for - Bank Guarantee Format for SD (please refer www.grse.in →Tender→Enclosures Related to tenders of Sub-Contracting Activities)
20.	Format for - Bank Guarantee Format for PBG (please refer www.grse.in →Tender→Enclosures Related to tenders of Sub-Contracting Activities)
21.	Guide line for Bank Guarantee (please refer www.grse.in →Tender→Enclosures Related to tenders of Sub-Contracting Activities)

ARTICLE/अनुच्छेद 24. DOCUMENTS TO BE UPLOADED अपलोड हेतु दस्तावेज

a. Self-Attested documents are to be scanned and uploaded with Part I of e-bid / ई-बिड के भाग-1 के साथ स्कैन एवं अपलोड हेतु स्वअभिप्रामाणित दस्तावेज

b. NON-SUBMISSION / INCOMPLETE SUBMISSION IN RESPECT TO BELOW-MENTIONED DOCUMENTS MAY LEAD TO REJECTION OF BID

Sl. No.	Description
1.	DD/PO or MSE/NSIC Exemption certificate towards tender fee
2.	DD/PO /BG or MSE/NSIC Exemption certificate towards EMD
3.	Integrity Pact (For Tenders above INR 2 Cr)
4.	Registration Certificate of the Company with ROC / Trade License
5.	PAN, TAN, GST
6.	Copies of registration with PF, ESI authorities.
7.	Government e-Market Place (GeM) registration certificate with Unique GeM Seller ID



Sl. No.	Description
8.	The Registration Number allotted to MSME's by Trades Receivable e-Discounting System (TReDS)
9.	Partnership Deed / Memorandum and the Article of Association of the firm confirming partners and lead partner (If applicable)
10.	Joint Venture Agreement / Memorandum of Understanding with Power of Attorney in favour of lead member. (If applicable)
11.	Acceptance Matrix for NIT
12.	Acceptance Matrix for Standard Terms & Conditions
13.	Acceptance Matrix for SoTR
14.	Format for Technical Eligibility Criteria
15.	Format for Financial Eligibility Criteria
16.	Audited/Certified Annual Accounts and Annual Report for immediate last three (03) financial years ending on 31st Mar'21 in support of Financial Eligibility.
17.	Self-Certification for Blacklisting / Tender Holiday
18.	Disclosure by Contractor of existing work load
19.	Disclosure by Contractor of proposed execution plan including proposed deployment of resources of this tendered job
20.	Work execution plan / schedule in MS Project clearly indicating dependencies
21.	Confirmation by Bidder & Checklist for Bid Submission
NON-SUBMISSION / INCOMPLETE SUBMISSION IN RESPECT TO ABOVE MAY LEAD TO REJECTION OF BID	

The Bidders has to submit ink signed hard copy of all above documents within 05 days from opening of Part I bid.

The Bidders should mention the following:

- "Unique Seller ID" allotted by GeM (Government e-Market Place) and
- The Registration Number allotted by Trades Receivable e-Discounting System (TReDS). The TReDS Registration Number is only applicable for MSME firms.

The Bidders not registered for Sl. No. 7 & 8 above should apply for registration of the following facilities in portals as per directives of the Government of India.

- GeM (Government e-Market Place) → website: <https://gem.gov.in>
- TReDS (Trades Receivable e-Discounting System) → website: www.invoicemart.com

Vendors Registered with GRSE are not required to upload documents at Sl. No. 4, 5 & 6 above, and are instead required to mention the Vendor Code allotted by GRSE.

ARTICLE/अनुच्छेद 25. DOCUMENTS IN PHYSICAL FORM TO SUBMIT वास्तविक प्रपत्र जो जमा करने हैं

PHYSICAL SUBMISSION		
1	EMD Instrument	Within 05 days from opening of Part I bid
2	Integrity Pact & Non-Disclosure Agreement	Within 05 days from opening of Part I bid
NOTE:	If instruments submitted through demand draft, the same to be drawn in favor of	GARDEN REACH SHIPBUILDERS & ENGINEERS LIMITED
	The demand drafts should be payable at	KOLKATA
	Above mentioned original Negotiable Instruments as stipulated, to reach the office of General Manager, Contract Cell, Commercial Department, New Building complex, 1 st Floor, GRSE Main Unit, 43/46, Garden Reach Road, Kolkata-700 024 within stipulated period as indicated above in a sealed envelope with tender number and job duly superscripting on it (preferably through speed post /courier service).	
NON-SUBMISSION / INCOMPLETE SUBMISSION IN RESPECT TO ABOVE MAY LEAD TO REJECTION OF BID		



ARTICLE/अनुच्छेद 26. SUBMISSION OF BID बिड की पेशी

- i. Last date of submission of Bid / Date of opening of bid is indicated in Tender Document. Tender is liable to be rejected if all the requisite documents are not enclosed with the Part I, Techno-Commercial offer. However, if the scanned copies are not uploaded with Part-I bid, then the original copies are to be submitted within 05 days from opening of Part I bid.
- ii. Date of opening of Part II offer i.e. Price Bid will be notified to all Techno-Commercially qualified bidders in due course after conclusion of TNC/CNC meetings and acceptance of Techno-Commercial offer. After opening of e-Price bids, the techno-commercially qualified bidders can view the System Generated Price Comparison Sheet from their own portal.
- iii. GRSE reserves the right to accept / reject any Tender in full or in part without assigning any reason.
- iv. Acceptance Format Matrix should be filled up and attached with techno-commercial bid as marks of acceptance of NIT/SOTR/STAC. In case of non-receipt of filled in STACs acceptance format matrix, it would be presumed that you have accepted all our terms& conditions as per GRSE tender until & unless deviation is specially mentioned in offer.

ARTICLE/अनुच्छेद 27. PRE-BID MEETING बोलीपूर्व बैठक

- i. Bidders are requested to forward their queries over email to the e-mail address: **Chattoraj.M.M@grse.co.in** with copy to **Kar.Nilanjan@grse.co.in** within 12:00 noon of 06-July-2023.
- ii. Pre-bid meeting shall be held at Central Design Office of GRSE located at GRSE Main Unit, 43/46, Garden Reach Road, Kolkata - 700024 on date as mentioned under Cardinal Dates.
- iii. The dates & time related to Prebid Meeting shall prevail over SOTR.



GARDEN REACH SHIPBUILDERS & ENGINEERS LTD.

गार्डन रीच शिपबिल्डर्स एण्ड इंजीनियर्स लिमिटेड

(A GOVERNMENT OF INDIA UNDERTAKING) / (भारत सरकार का प्रतिष्ठान)

Address: 61, Garden Reach Road, Kolkata-700 024 61, गार्डन रीच रोड, कोलकाता-700 024

Phone/दूरभाषः:(033) 2469-8140 to 8143, FAXफैक्सः (033) 2469-8144

Web siteवेबः www.grse.in, E-Mailई मेलः Gupta.Manoj@grse.co.in

CIN / सी आई एनः L35111WB1934GOI007891

ANNEXURE-1A: STATEMENT OF TECHNICAL REQUIREMENTS (SoTR) & DRAWINGS

NIT SLA No / निविदा संख्या:	SCC/NK/NIC/OT/CDO/Valves/019/ET-2018 DTD: 14-Oct-2023
Job Title / कार्य का नाम	RE-SIZING / REFURBISHMENT OF VALVES
SOR No:	GT61410014M/A Rev.03 dt. 10.07.23 (Annexure-1A)
Tender issuing Dept. / बिभाग द्वारा जारी	Contract Cell (संविदा बिभाग)



GARDEN REACH SHIPBUILDERS AND ENGINEERS LIMITED

(A Govt. Of India Undertaking)

CENTRAL DESIGN OFFICE: DESIGN ENGINEERING 61 PARK,
61 GARDEN REACH ROAD, KOLKATA - 700024

STATEMENT OF TECHNICAL REQUIREMENT FOR RE-SIZING / REFURBISHMENT OF VALVES SOTR No. GT61410014M/A Rev.02

HISTORY OF REVISION

REV	DATE	DESCRIPTION	PRP D. BY	CHK D. BY	APPROVED BY
03	10.07.23	Delivery Terms incorporated at para 6(viii) of Sec-A.	SM(D)(E)	AGM(D)(E)	AGM(D)(E)
02	26.06.23	Guarantee / Warranty Terms incorporated at para 6(vii) of Sec-A.	SM(D)(E)	AGM(D)(E)	AGM(D)(E)
01	05.06.23	a) Details of GM Flanges included b) Receipt inspection clause included	SM(D)(E)	AGM(D)(E)	AGM(D)(E)
00	30.05.23	INITIAL ISSUE	SM(D)(E)	AGM(D)(E)	AGM(D)(E)



	GRSE LTD. (A Govt. of India Undertaking) 43/46 Garden Reach Road, Kolkata - 700024	STATEMENT OF TECHNICAL REQUIREMENT FOR RE-SIZING / REFURBISHMENT OF VALVES	
		SOTR NO	GT61410014M/A
		REV. NO.	03
		DATE	10.07.2023
PROJECT-P17A YARD-3022		PAGE NO.	Page 2 of 32

SECTION-A:
GENERAL REQUIREMENT

1. INTRODUCTION:

GRSE is presently holding an inventory of gunmetal valves from ex-projects at FOJ Unit. The list of such valves is placed at **Annexure-I**. GRSE intends to refurbish/re-size these surplus valves into 143 nos GM valves and GM flanges as listed at **Annexure-II**, as per the technical specification indicated in this SOTR, for utilization on P17A ship (Yd-3022).

2. PRE-QUALIFICATION CRITERIA:

The firm should be manufacturer of valves with past experience in design, manufacturing, supply of valves for naval ships. Firm has to submit past supply order copy for supplying of valves in last three years to Navy or any reputed shipyards in India, in support of the pre-qualification criteria.

3. PRE-TENDER VISIT TO GRSE SITE:

A pre-bid site visit at GRSE/FOJ Unit is to be conducted by the bidding firms along with GRSE reps to assess the condition of the surplus material. Any ambiguity regarding understanding of scope have to be resolved by the firm in consultation with GRSE during this visit & accordingly Firm has to submit visit report for pre-bid site visit along with the bid. Any non-conformity will be liable for rejection of the offer.

4. SUPPLIER'S OFFER:

Supplier has to submit the following documents along with the offer-

- (a) Preliminary GA with part list.
- (b) Accepted & signed copy of model QAP (**Annexure-V**)
- (c) Certificate of conformity duly filled, signed & stamped (**Annexure-III**)
- (d) Deviation form dully filled (**Annexure-IV**)
- (e) Weight of valve in weight control data sheet.
- (f) Clause wise conformation to all points (Compliance Matrix)
- (g) Details of past supply of valve with same design to IN/Shipyard with purchase order copies.

5. MODALITY OF RE-FURBISHMENT/RE-SIZING:

Post placement of order the exact weight of the surplus valves will be determined & certified by GRSE & Supplier and subsequently firm will collect the surplus valves (**Annexure-I**) from GRSE site. Then the firm will extract the necessary raw material from these surplus valves at firm's premises and then the same will be utilized by the firm into making the new valves as per **Annexure-II**. Any material required over & above surplus material, for manufacturing of the valves as per this technical specification, is to be provided by the supplier. Prior delivery, firm has to demonstrate that the total weight of the re-furbished valves (**Annexure-II**) is identical (or greater) than the total weight of the surplus valves (**Annexure-I**) provided by GRSE.



	GRSE LTD. (A Govt. of India Undertaking) 43/46 Garden Reach Road, Kolkata - 700024	STATEMENT OF TECHNICAL	SOTR NO	GT61410014M/A
		REQUIREMENT FOR RE-SIZING /	REV. NO.	03
		REFURBISHMENT OF VALVES	DATE	10.07.2023
		PROJECT-P17A YARD-3022	PAGENO.	Page 3 of 32

6. **SUPPLIER'S SCOPE OF WORK:**

- i. Picking up old surplus valves from GRSE FOJ Unit. Post placement of order the firm will provide 3 days notice for collecting the surplus valves from GRSE site. All the necessary logistics & manpower for collecting valves from GRSE site to be arranged by the firm.
- ii. Manufacturing of 143 nos valves (approx.) as per this technical specification through re-sizing/ refurbishment of the surplus valves provided by GRSE. The list of valves to be manufactured in placed at **Annexure-II**.
- iii. The raw material is to be tested during the re-sizing by the valves by the supplier & the test certificate is to be reviewed by inspection agency as per QAP.
- iv. All the manufacturing stage inspection including raw material verification, pressure testing of the resized and re-furbished valves is to be carried out by the firm as per QAP.
- v. Delivery of 143 nos valves (approx.) along with test certificates, as per **Annexure-II**, having weight equivalent to old surplus valves listed in **Annexure-I**, taken from GRSE. Weight certificate of each valve have to be arrange by the vendor through TPIA inspection agency. Any course correction in delivery qty of valve based on certified weight of manufactured valve will be done prior delivery of the valve to GRSE to adjust the equivalent weight of old surplus valves listed in **Annexure-I**. Firm to submit certified weight report to GRSE to finalize the final qty of valve prior delivery of valve to GRSE.
- vi. Repair/rectification/replacement as applicable in case any deficiency if observed during Shop pressure test at GRSE post receipt of the valves.
- vii. **Guarantee / Warranty:** The materials are to be guaranteed /warranted for satisfactory performance for the period of **12 Months** from the date of commissioning of the respective ship on which the equipment/materials/items are installed or **36 months** from the receipt of last consignment of equipments /materials/items at GRSE **whichever is earlier** against improper design, defective materials and faulty workmanship. During guarantee/ warrantee period any equipment or component thereof supplied by the vendor, suffers due to defective material and or due to improper design and or due to defective drawing or due to faulty workmanship the vendor will assume full responsibility of rectification of such defective equipment or component thereof including direct expenses related to removal and re-positioning of the replacement/repared equipment or component thereof and subsequent test & trial, incurred thereon without any financial implication to GRSE. Issues/Defects related to Guarantee/Warranty shall have to be liquidated at the location of vessel and/or as desired by the Purchaser / Owner, at no extra cost.
- viii. **Delivery:** 04 months from the date of placement of order/LOA.

7. **GRSE'S SCOPE:**

GRSE will co-ordinate for the followings -

- I. GRSE will co-ordinate for pre-bid visit at FOJ Unit for assessment of surplus valves.
- II. Post placement of order GRSE will co-ordinate with the firm for weight certification of the surplus valves and handing over the same to the firm.

8. **DESIGN/ DRAWINGS:**

Within 07 days from placement of order, the firm will submit the binding drgs of the deliverable valves (**Annexure-II**) to GRSE for approval. The valves are to be manufactured in accordance to this specification & approved binding drg.



	GRSE LTD. (A Govt. of India Undertaking) 43/46 Garden Reach Road, Kolkata - 700024	STATEMENT OF TECHNICAL REQUIREMENT FOR RE-SIZING / REFURBISHMENT OF VALVES		SOTR NO	GT61410014M/A
				REV. NO.	03
				DATE	10.07.2023
		PROJECT-P17A YARD-3022		PAGE NO.	Page 4 of 32

9. QUALITY ASSURENCE PLAN:

The model QAP is placed at **Annexure-V** of this specification. Within 07 days from placement of order, the firm will submit the QAP to GRSE/QA for approval. The valves are to be manufactured in accordance to this specification & approved QAP.

10. INSPECTION:

Quality control stage inspections are to be carried out by firm in accordance to approved QAP. The inspection will be witnessed by GRSE/QA or TPIA nominated by GRSE/QA. Inspection charges (if any) will be borne by GRSE. Receipt inspection & certification will be undertaken by FOJ/Eng dept.

11. DOCUMENTATION:

Each consignment is to be accompanied by following drawings & documents-

SL NO.	Type of Documents/Drawings	Sets
(a)	As Fitted Drawings	2
(c)	Material Test Certificate	2
(d)	Inspection Certificate	2
(f)	Weight Certificates	2

12. PACKING/FORWARDING & PRESERVATION:

- i. Valve supplier is to provide high quality packing for the complete scope of supply along with handling arrangements. The package/container should display clear instructions for stowage, handling, care and accessibility for inspection of equipment preservation condition.
- ii. The Valves are to be preserved on delivery as per the standard marine engineering practice. Closing plates/plugs/caps are to be provided on all openings.
- iii. All Valves are to be packed in separate cases for each type. Each package is to be clearly marked to indicate its content, Quantity, PO Number & Correlate it with manufacturer 's Test Certificate.
- iv. Moisture / Corrosion Protection- Only VCI treated materials shall be used in direct contact with metallic items during packing. Appropriate class of VCI material shall be used for ferrous / non-ferrous items. Adequate measures would be taken to preserve soft material fitted inside valves and supplied as spares.
- v. All machined surfaces shall be suitably protected against mechanical damage. Valves larger than 100 mm shall be bolted or otherwise fastened to skids to avoid damage in subsequent handling.
- vi. Full-face flange protectors of waterproof Plywood/weather resistant Pressboard or plastic, of at least the outside diameter of the flange, shall be fastened to the flange to protect both flange & Valve interiors.
- vii. Delivery of the valve at GRSE premises & regularization of issue challan vs delivery challan have to be arranged by the vendor.



	GRSE LTD. (A Govt. of India Undertaking) 43/46 Garden Reach Road, Kolkata - 700024	STATEMENT OF TECHNICAL	SOTR NO	GT61410014M/A
		REQUIREMENT FOR RE-SIZING /	REV. NO.	03
		REFURBISHMENT OF VALVES	DATE	10.07.2023
		PROJECT-P17A YARD-3022	PAGE NO.	Page 5 of 32

SECTION-B:
TECHNICAL REQUIREMENT

13. GENERAL DESIGN REQUIREMENT:

- i. The Material, Dimension, Construction & Testing requirement of valves shall conform to the Codes /Standards specified in the valve data sheet placed in **SECTION-C**.
- ii. Valves with rod gearing requirement are to be non-rising spindle type & should have provision for rod gearing operation through an extended hex on the spindle (45mm above wheel and 25mm sq.)
- iii. The valves are to be designed to offer minimum pressure drop (C_v) during flow. The manufacturer is to submit Flow coefficient (C_v) for each type of valve for approval.
- iv. Valve body thickness wherever not specified in the standard shall be as per ANSI B16.34. To arrive at the minimum valve body thickness, in accordance with BS 5351 / ASME B 16.34 for Class 150, the valve designer should suitably incorporate applicable allowance based on corrosion / manufacturing allowance.
- v. An arrow to be embossed on the body to indicate the direction of flow (As applicable). Stops shall be provided to ensure positive alignment of valves with the ports.
- vi. Valve OPEN & CLOSED indicator shall be provided. All valves shall have locking arrangement.
- vii. All valves shall be field serviceable. In case of leakage through gland, the technicians/watch keeper on board the ship should be able to change the gland packing/seal even though the fluid is flowing through the valve under pressure (Back Seat provision)
- viii. The valve offered should operate smoothly under tropical marine conditions. It shall withstand contamination through air, oil, salt water & other contaminants associated with the marine environment.
- ix. The valves shall be designed suitably to withstand shock loading without any portion of the equipment coming adrift or creating a hazard to personnel or to any other equipment.
- x. Rubber seats/seals used in to the valve body & penetrated by the valve spindle shall be adequately reinforced to prevent the seat from getting inflated by pressure behind the seat. Circumferential joints of the rubber seats shall be bonded together.
- xi. Rubber components of Valve shall be designed such that it permits removal & replacement at the site of the installation. Rubber seats shall be clamped mechanically secured or bonded to the body or disc. Method of bonding shall be tested in accordance with ASTM D429.
- xii. Spring used shall be helical type. Supplier to provide data sheet of spring with spring constant, material & spring life cycle.
- xiii. All fasteners/ pins etc are to have positive locking devices to ensure that they do not open while in use.
- xiv. All valves 40kg & above shall be provided with permanent lifting arrangement for ease of handling on board the ship.
- xv. The surface of the castings shall be examined visually and shall be free of adhering sand, scale, cracks & hot tears. Other surface discontinuities shall meet the visual acceptance standard SP55. Un-acceptable visual surface discontinuities shall be removed & their



	GRSE LTD. (A Govt. of India Undertaking) 43/46 Garden Reach Road, Kolkata - 700024	STATEMENT OF TECHNICAL REQUIREMENT FOR RE-SIZING / REFURBISHMENT OF VALVES		SOTR NO	GT61410014M/A
				REV. NO.	03
		PROJECT-P17A YARD-3022		DATE	10.07.2023
				PAGE NO.	Page 6 of 32

removal verified by visual examination of the resultant cavities. The castings shall not be peened, plugged or impregnated to stop leaks.

14. END CONNECTIONS:

Valve End flanges shall be cast or forged integral with the body. Flanges are to conform to BS 4504 SEC. 3.3 (321) Raised Face for pressure rating PN 10. The flange thickness shall be as per code 321 (raised face) of BS 4504 part 3.3 for PN 10 rating.

15. OPERATION:

- i. All GATE, SDNR, SDSL & Storm Valves are operated by hand wheel or Rod gearing (from remote place.)
- ii. The Ball/Butterfly valves may be operated by hand lever/ wrench/ gearbox / Actuators or Rod gearing (from remote place.)
- iii. **All Ball /Plug Valves/Butterfly valves up to 125NB (Including) in size are to be Lever Operated unless otherwise specified in valve description & Valves above 150NB (including) are to be Gear Operated.**
- iv. Manually operated valves shall be clockwise closing type, unless otherwise specified.
- v. The design of the valve is to ensure an ease of operation so that single arms clear pull of not more than 140 N is required by an operator or 70 N by each hand on the hand wheel/lever. Vendor to provide the actual torque (CERTIFIED) required for the valve operation of the offered valves
- vi. The gearboxes fitted on valves are to be considered as the integral part of the valve & designed to anti corrosion & shock requirements of the valve itself. All gear boxes are to be water tight at 5 metre water column.
- vii. Hand wheels/levers/ gearboxes shall be marked to indicate the direction of opening & closing.

16. MATERIAL:

- i. Materials used in manufacturing of valves shall be such that it is compatible with all low-pressure fluids in surface ships.
- ii. Material requirements with specification, for various components of valves are given in **SECTION-C.**
- iii. All fasteners shall be forged type only. Fasteners to confirm NES 862 & shall have rolled threads. Machining of fasteners from rolled bars is not acceptable.
- iv. All rolled bars shall have elongation minimum 17%
- v. Castings shall be of a radiograph quality without any defect when inspected visually. Forged & rolled materials shall be free from lap, cracks etc. Valve body seat & other stress parts are of radiograph quality.
- vi. All raw material used for manufacturing shall be new virgin material only.
- vii. Rubber Components shall contain not more than 8 ppm of Cu ion & shall include Copper inhibitors to prevent Copper degradation of the rubber materials.
- viii. Rubber compounds shall be free of vegetable oil derivatives, animal fats & animal oils.



	GRSE LTD. (A Govt. of India Undertaking) 43/46 Garden Reach Road, Kolkata - 700024	STATEMENT OF TECHNICAL REQUIREMENT FOR RE-SIZING / REFURBISHMENT OF VALVES		SOTR NO	GT61410014M/A
				REV. NO.	03
				DATE	10.07.2023
		PROJECT-P17A YARD-3022		PAGENO.	Page 7 of 32

Reclaimed/recycled rubber shall not be used. Rubber compound shall contain not more than 1.5 parts of wax per 100 parts of rubber hydrocarbon.

- ix. All castings shall be Class-II quality as per NES 747.
- x. All valves shall be designed to ensure that in the event of the gland being removed while the valve is under pressure, the stem does not blow out of the body.
- xi. The passage for the flow of fluid shall be clear & smooth. The flow area shall be not less than 90% of bore area. The valves shall be full-bore type.

17. VALVE BODY MARKING:

Body marking shall be integral with the body or on a stainless steel (SS316) Plate securely fixed to the body. The marks shall be clear & distinct for identification & shall contain the following details:

- i. Valve Type
- ii. Nominal Size
- iii. Nominal Pressure Rating
- iv. Body Material Designation
- v. Manufacturer's Name or Trade Mark
- vi. Markings to indicate valve open or closed condition.
- vii. Project Name, Order No. Fitting No.
- viii. An arrow indicating the direction of flow when this is unique.
- ix. Body Test Pressure.

18. VALVE SPECIFICATIONS:

i) Butterfly valves

- (a) All butterfly valves shall comply with BS 5155 requirements.
- (b) All butterfly valves shall be Lugged type in design.
- (c) All butterfly valves shall have antistatic arrangement to ensure electrical continuity between stem & body of Valves.

ii) Gate/SDSL/SDNR valve

- (a) All GATE / SDNR / SDSL valves shall comply with BS 5154/BS MA65 requirements.
- (b) All GATE / SDNR / SDSL valves shall be of non-rising spindle with inside screw type.
- (c) The GATE (wedge) / Disc shall be solid type.
- (d) All GATE / SDNR / SDSL valves shall have back seat arrangement.

iii) Check valves

- (a) All check valves shall comply with BS 5154/BS MA65/BS1868 requirements.
- (b) The disc shall be solid type
- (c) The full port area shall be maintained without pockets from the inlet port to the valve seat to avoid turbulence.
- (d) At the outlet side of the valve seat the body shall be designed such that it allows sufficient swing of the disk to give a flow area at least equivalent to full port area.
- (e) The Lift check valves shall be spring type.
- (f) All check valves are to be tested at low pressure test (15 PSI air medium).

iv) Pressure reducing valve

- (a) All Valves are to be positively tight at pressure below the set pressure.
- (b) Reducing valves are to be of the fluid tight enclosed spring type, with enclosures vented to the



	GRSE LTD. (A Govt. of India Undertaking) 43/46 Garden Reach Road, Kolkata - 700024	STATEMENT OF TECHNICAL		SOTR NO	GT61410014M/A
		REQUIREMENT FOR RE-SIZING /		REV. NO.	03
		REFURBISHMENT OF VALVES		DATE	10.07.2023
		PROJECT-P17A YARD-3022		PAGE NO.	Page 8 of 32

- outlet side of the valve. Springs shall be of Helical Compression Springs type only.
- (c) The springs in valves are not to be in contact with the fluid enclosed.
 - (d) The coefficient of flow is to be calculated as per standard & is to be indicated in drawing.
 - (e) The proportional band & degree of stability on step change of demand are also to be indicated.
- v) **Diaphragm valve**
- (f) These valves can be considered for isolation as well as regulation purpose, particularly where throttling of fluid is required or in vacuum lines to obviate leakage through spindle glands



	GRSE LTD. (A Govt. of India Undertaking) 43/46 Garden Reach Road , Kolkata - 700024	STATEMENT OF TECHNICAL REQUIREMENT FOR RE-SIZING / REFURBISHMENT OF VALVES		SOTR NO	GT61410014M/A
		PROJECT-P17A YARD-3022		REV. NO.	03
				DATE	10.07.2023
		PAGE NO.	Page 9 of 32		

SECTION-C:
VALVE DATA SHEETS



	GRSE LTD. (A Govt. of India Undertaking) 43/46 Garden Reach Road, Kolkata - 700024	STATEMENT OF TECHNICAL REQUIREMENT FOR RE-SIZING / REFURBISHMENT OF VALVES		SOTR NO	GT61410014M/A
				REV. NO.	03
				DATE	10.07.2023
		PROJECT-P17A YARD-3022		PAGE NO.	Page 10 of 32

VALVE DATA SHEET GUN METAL BUTTERFLY VALVES					
1	GENERAL SPECIFICATION				
1.1	FLUID HANDLED	FW,CW,SW,F.O.L.O etc	1.7	BORE TYPE	FULL BORE
1.2	OP. PRESSURE	10 Kg / Cm ²	1.8	END CONN.	LUGGED BS4504-3.3
1.3	OP. TEMPERATURE	120 °C MAX.	1.9	FACE-TO-FACE DIST.	REFER DATASHEET
1.4	SIZE RANGE	REFER DATASHEET	1.10	FLANGE FACE	-
1.5	MATING PIPE SPECN.	90-10Cu-Ni (NES779)/CU (NES837)/ ASTM A106 GR.B	1.11	BODY TYPE	SINGLE PIECE
1.6	VALVE REF.DOC.	NES 375 / BS 5155	1.12	VALVE OPERATION	HANDLE/GEAR
2	MATERIAL SPECIFICATION				
	PART	MATERIAL	SPECIFICATION		
2.1	BODY /COVER	GUN METAL	BS 1400 LG 4C		
2.2	DISC	NICKEL ALUMINIUM BRONZE	NES PART 747 II		
2.3	STEM/SPINDLE	NICKEL ALUMINIUM BRONZE	NES 833 PART II		
2.4	CLAMP RING	NICKEL ALUMINIUM BRONZE	NES 747 PART II		
2.5	DISC PIN	NICKEL ALUMINIUM BRONZE	NES 833 PART II		
2.6	SOFT SEAT	REINFORCED PTFE	REINFORCED WITH 90/10 Cu-Ni		
2.7	BODY SLEEVE	REINFORCED PTFE	REINFORCED WITH 90/10 Cu-Ni		
2.8	BEARING	PHOSPHOR BRONZE	BS 2872 PB 102		
2.9	GLAND FLANGE	NICKEL ALUMINIUM BRONZE	NES 747 PART II		
2.10	GLAND PACKING	GRAPHITE			
2.11	BODY GASKET	ASBESTOS FREE	BS 7531		
2.12	BOLTS	NICKEL ALUMINIUM BRONZE	NES 862		
2.13	NUTS	NICKEL ALUMINIUM BRONZE	NES 862		
2.14	HANDLE/HANDWHEEL	FORGED STEEL/CAST STEEL (GALVANIZED)	ASTM A105/ASTM A216 WCB		
2.15	ANTISTATIC DEVICE	STAINLESS STEEL	ASTM A 276 Gr 304		
2.16	GEAR BOX CASING	GUN METAL	BS 1400 LG 4C		
2.17	GEARS	PHOSPHOR BRONZE	BS 2872 PB 102		
2.18	WORM & WORM WHEEL SPINDLE	NICKEL ALUMINIUM BRONZE	NES 833 PART II		
3	STATUTORY REQUIREMENTS				
3.1	PAINTING/ SURFACE FINISH	SMOOTH SURFACE WITH METAL FINISH			
3.2	INSPECTION & TESTING	API 598			
3.3	TESTING HYDROSTATIC	AS PER BS 6755 PART I for RATE 'A'			
3.4	HYDROSTATIC TEST PRESSURE	BODY - 15 BAR SEAT - 11 BAR			
3.5	PNEUMATIC TEST PRESSURE	7 BAR WITH VALVE CLOSED			
3.6	PRESSURE DROP TEST/FLOW MEASUREMENT TEST	ACROSS VALVE			
3.7	REPEATABILITY TEST	25 CYCLE MINIMUM FOLLOWED BY HYDROTEST			
3.8	RUBBER BONDING TESTING	ASTM D 429			
3.9	ANTISTATIC TEST	AS PER BS 5146 (" IF APPLICABLE)			
3.10	NOISE MEASUREMENT	MIL-STD-740-2			
3.11	GEAR BOX TESTING	LEAK TEST AT 5 METRES OF WATER COLUMN			
3.12	CERTIFICATION	GRSE/QA/TPIA			
3.13	INSPECTION	GRSE/QA/TPIA			



	GRSE LTD. (A Govt. of India Undertaking) 43/46 Garden Reach Road, Kolkata - 700024	STATEMENT OF TECHNICAL REQUIREMENT FOR RE-SIZING / REFURBISHMENT OF VALVES		SOTR NO	GT61410014M/A
				REV. NO.	03
				DATE	10.07.2023
		PROJECT-P17A YARD-3022		PAGENO.	Page 11 of 32

VALVE DATA SHEET					
NICKEL ALUMINIUM BRONZE BUTTERFLY VALVES					
1	GENERAL SPECIFICATION				
1.1	FLUID HANDLED	SEA WATER/BILGES	1.7	BORE TYPE	FULL BORE
1.2	OP. PRESSURE	10 Kg / Cm ²	1.8	END CONN.	FLANGED BS4504-3.3
1.3	OP. TEMPERATURE	120 °C MAX.	1.9	FACE-TO-FACE DIST.	REFER DATASHEET
1.4	SIZE RANGE	REFER DATASHEET	1.10	FLANGE FACE	-
1.5	MATING PIPE SPECN.	90-10 Cu-Ni as per NES 779 Part III	1.11	BODY TYPE	SINGLE PIECE
1.6	VALVE REF.DOC.	NES 375 / BS 5155	1.12	VALVE OPERATION	LEVER / GEAR
2	MATERIAL SPECIFICATION				
	PART	MATERIAL	SPECIFICATION		
2.1	BODY /COVER	NICKEL ALUMINIUM BRONZE	NES PART 747 II		
2.2	DISC	NICKEL ALUMINIUM BRONZE (SOLID)	NES PART 747 II		
2.3	SHAFT/SPINDLE	NICKEL ALUMINIUM BRONZE	NES 833 PART II		
2.4	CLAMP RING	NICKEL ALUMINIUM BRONZE	NES 747 PART II		
2.5	DISC PIN	NICKEL ALUMINIUM BRONZE	NES 833 PART II		
2.6	SOFT SEAT	REINFORCED PTFE	REINFORCED WITH 90/10 Cu-Ni		
2.7	BODY SLEEVE	REINFORCED PTFE	REINFORCED WITH 90/10 Cu-Ni		
2.8	BEARING	PHOSPHOR BRONZE	BS 2874 PB 102		
2.9	GLAND FLANGE	NICKEL ALUMINIUM BRONZE	NES 833 PART II		
2.10	GLAND PACKING	GRAPHITE			
2.11	BODY GASKET	ASBESTOS FREE	BS 7531		
2.12	BOLTS	NICKEL ALUMINIUM BRONZE	NES 862		
2.13	NUTS	NICKEL ALUMINIUM BRONZE	NES 862		
2.14	HANDLE/HANDWHEEL	STAINLESS STEEL(WITH PVC GRIP)	ASTM A105/ASTM A216 WCB		
2.15	ANTISTATIC DEVICE	STAINLESS STEEL	ASTM A 276 Gr.304		
2.16	GEAR BOX CASING	GUN METAL	BS 1400 LG 4C		
2.17	GEARS	PHOSPHOR BRONZE	BS 2874 PB 102		
2.18	WORM & WORM WHEEL SPINDLE	NICKEL ALUMINIUM BRONZE	NES 833 PART II		
3	STATUTORY REQUIREMENTS				
3.1	PAINTING/ SURFACE FINISH	SMOOTH SURFACE WITH METAL FINISH			
3.2	INSPECTION & TESTING	API 598			
3.3	TESTING HYDROSTATIC	AS PER BS 6755 PART I for RATE 'A'			
3.4	HYDROSTATIC TEST PRESSURE	BODY – 15 BAR SEAT – 11 BAR			
3.5	PNEUMATIC TEST PRESSURE	7 BAR WITH VALVE CLOSED			
3.6	PRESSURE DROP TEST/FLOW MEASUREMENT TEST	ACROSS VALVE			
3.7	REPEATABILITY TEST	25 CYCLE MINIMUM FOLLOWED BY HYDROTEST			
3.8	RUBBER BONDING TESTING	ASTM D 429			
3.9	ANTISTATIC TEST	AS PER BS 5146 (° IF APPLICABLE)			
3.10	NOISE MEASUREMENT	MIL-STD-740-2			
3.11	GEAR BOX TESTING	5 METRES OF WATER COLUMN			
3.12	CERTIFICATION	GRSE(QA)/TPIA			
3.13	INSPECTION	GRSE(QA)/TPIA			

 GRSE LTD. (A Govt. of India Undertaking) 43/46 Garden Reach Road, Kolkata - 700024	STATEMENT OF TECHNICAL REQUIREMENT FOR RE-SIZING / REFURBISHMENT OF VALVES PROJECT-P17A YARD-3022	SOTR NO	GT61410014M/A
		REV. NO.	03
		DATE	10.07.2023
		PAGENO.	Page 12 of 32

BUTTERFLY VALVE (LEVER OPERATED TYPE)

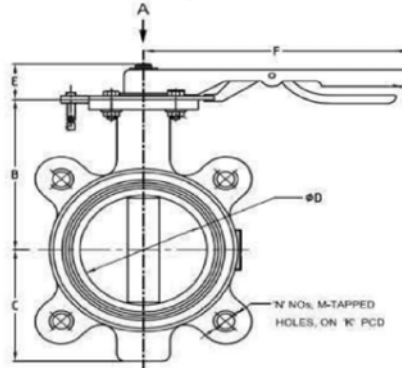

BUTTERFLY VALVE (GEAR OPERATED TYPE)

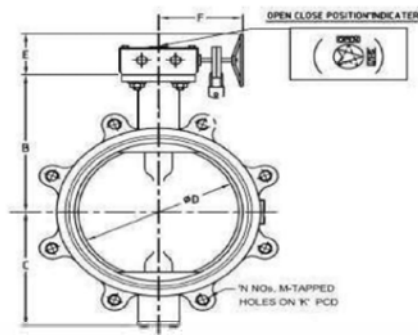

***NOTE:**

Drawings attached in SOTR are for reference and clear understanding of valve only

L-VALVE FACE TO FACE DIMENSIONS

Sl. No.	Nominal Size (DN)	Face to face dimensions (L)
1	80	64
2	100	64
3	125	70
4	150	76
5	200	89
6	250	114
7	300	114
8	350	127
9	400	140



 GRSE LTD. (A Govt. of India Undertaking) 43/46 Garden Reach Road, Kolkata - 700024	STATEMENT OF TECHNICAL REQUIREMENT FOR RE-SIZING / REFURBISHMENT OF VALVES		SOTR NO	GT61410014M/A
			REV. NO.	03
	PROJECT-P17A YARD-3022		DATE	10.07.2023
			PAGE NO.	Page 13 of 32

VALVE DATA SHEET					
NICKEL ALUMINIUM BRONZE STRAIGHT & ANGLE TYPE SDNR / SDSL AND GATE VALVES					
1	GENERAL SPECIFICATION				
1.1	FLUID HANDLED	SEA WATER/BILGES	1.7	BORE TYPE	FULL BORE
1.2	OP. PRESSURE	10 Kg/Cm ²	1.8	END CONN.	FLANGED
1.3	OP. TEMPERATURE	120 °C MAX.	1.9	FACE-TO-FACE DIST.	REFER DATASHEET
1.4	SIZE RANGE	REFER DATASHEET	1.10	FLANGE FACE	BS4504-3.3(RAISED FACE)
1.5	MATING PIPE SPECN.	90-10 Cu-Ni as per NES 779 Part III	1.11	BODY TYPE	BOLTED BONNET TYPE
1.6	VALVE REF. DOC.	NES 375 / BS 5154	1.12	VALVE OPERATION	HAND WHEEL / ROD GEARING (REMOTE)
2	MATERIAL SPECIFICATION				
	PART	MATERIAL	SPECIFICATION		
2.1	BODY / BONNET	NICKEL ALUMINIUM BRONZE	NES 747 PART II		
2.2	DISC/GATE	NICKEL ALUMINIUM BRONZE	NES 747 PART II		
2.3	SPINDLE	NICKEL ALUMINIUM BRONZE	NES 833 PART II		
2.4	BACK SEAT	NICKEL ALUMINIUM BRONZE	NES 747 PART II		
2.5	DISC SEAT	NICKEL ALUMINIUM BRONZE	NES 747 PART II		
2.6	SOFT SEAT	REINFORCED PTFE	REINFORCED WITH 90/10 CuNi		
2.7	YOKE/YOKE SLEEVE	NICKEL ALUMINIUM BRONZE	NES 747 PART II		
2.8	BEARING (BUSH)	PHOSPHOR BRONZE	BS 2874 PB 102		
2.9	GLAND FLANGE END	NAB	NES 747 PART II CLASS I		
2.10	GLAND PACKING	GRAPHITE (IMPREGNATED)			
2.11	BODY GASKET	ASBESTOS FREE	BS 7531		
2.12	BOLTS	NICKEL ALUMINIUM BRONZE	NES 862		
2.13	NUTS	NICKEL ALUMINIUM BRONZE	NES 862		
2.14	HAND WHEEL	CAST STEEL (GALVANIZED)	ASTM A 216 Gr. WCB		
2.15	TAB WASHER	STAINLESS STEEL	IS 8062 / ASTM A 240 Gr. 304		
3	STATUTORY REQUIREMENTS				
3.1	PAINTING/ SURFACE FINISH	SMOOTH SURFACE WITH METAL FINISH			
3.2	INSPECTION & TESTING	API 598			
3.3	TESTING HYDROSTATIC	AS PER BS 6755 PART I for RATE 'A'			
3.4	HYDROSTATIC TEST PRESSURE	BODY - 15 BAR SEAT - 11 BAR			
3.5	PNEUMATIC TEST PRESSURE	7 BAR WITH VALVE CLOSED CONDITION			
3.6	PRESSURE DROP TEST/FLOW MEASUREMENT TEST	ACROSS VALVE			
3.7	ANTISTATIC TEST	AS PER BS 5146 (* IF APPLICABLE)			
3.8	RUBBER BONDING TESTING	ASTM D 429			
3.9	REPEATABILITY TEST	25 CYCLE MINIMUM FOLLOWED BY HYDROTEST			
3.10	CERTIFICATION	GRSE(QA)/TPIA			
3.11	INSPECTION	GRSE(QA)/TPIA			



GRSE LTD.
(A Govt. of India Undertaking)
43/46 Garden Reach Road,
Kolkata - 700024

**STATEMENT OF TECHNICAL
REQUIREMENT FOR RE-SIZING /
REFURBISHMENT OF VALVES**

PROJECT-P17A YARD-3022

SOTR NO	GT61410014M/A
REV. NO.	03
DATE	10.07.2023
PAGE NO.	Page 14 of 32

SDNR / SDSL VALVE STRAIGHT TYPE

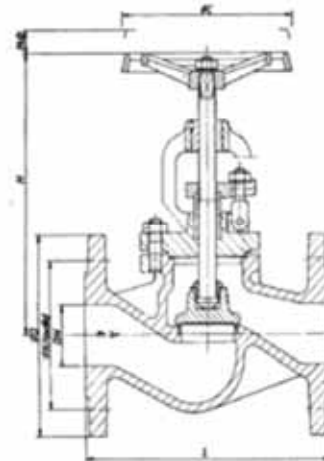

SDNR / SDSL VALVE ANGLE TYPE

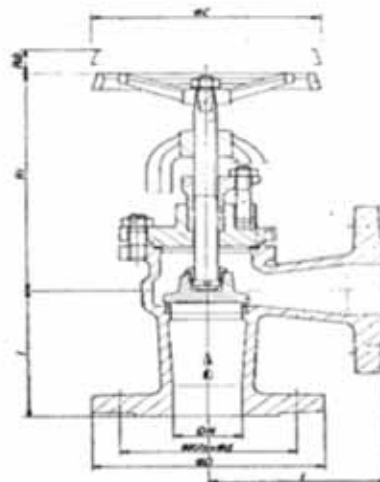

***NOTE:**

Drawings attached in SOTR are for reference and clear understanding of valve only



	GRSE LTD. (A Govt. of India Undertaking) 43/46 Garden Reach Road , Kolkata - 700024	STATEMENT OF TECHNICAL REQUIREMENT FOR RE-SIZING / REFURBISHMENT OF VALVES		SOTR NO	GT61410014M/A
				REV. NO.	03
				DATE	10.07.2023
		PROJECT-P17A YARD-3022		PAGENO.	Page 15 of 32

FACE -TO- FACE DISTANCE SDNR / SDSL / (STRAIGHT)					
L-VALVE FACE TO FACE DIMENSIONS (Inclusive of FLANGE THICKNESS)					
SR. NO.	NOMINAL SIZE	DIMENSIONS	END CONNECTION DETAILS	QTY. / SYSTEM	TOTAL QTY.
		L			
01	10	108	SCREWED		
02	15	108	SCREWED		
03	20	117	SCREWED		
04	25	127	SCREWED		
05	32	146	SCREWED		
06	40	159	FLANGED		
07	50	190	FLANGED		
08	65	216	FLANGED		
09	80	254	FLANGED		
10	100	292	FLANGED		
11	125	330	FLANGED		
12	150	356	FLANGED		
13	200	495	FLANGED		
14	250	622	FLANGED		
15	300	698	FLANGED		
16	350	787	FLANGED		

FACE -TO- FACE DISTANCE SDNR / SDSL VALVE DIMENSIONS (ANGLE)					
L -VALVE FACE TO FACE DIMENSIONS (Inclusive of FLANGE THICKNESS)					
SR. NO.	NOMINAL SIZE	DIMENSIONS	END CONNECTION DETAILS	QTY. / SYSTEM	TOTAL QTY.
		L			
01	10	70	SCREWED		
02	15	70	SCREWED		
03	20	75	SCREWED		
04	25	85	SCREWED		
05	32	95	SCREWED		
06	40	100	FLANGED		
07	50	115	FLANGED		
08	65	126	FLANGED		
09	80	135	FLANGED		
10	100	146	FLANGED		
11	125	178	FLANGED		
12	150	203	FLANGED		
13	200	248	FLANGED		
14	250	311	FLANGED		
15	300	349	FLANGED		
16	350	394	FLANGED		



GRSE LTD.
(A Govt. of India Undertaking)
43/46 Garden Reach Road ,
Kolkata - 700024

STATEMENT OF TECHNICAL
REQUIREMENT FOR RE-SIZING /
REFURBISHMENT OF VALVES

PROJECT-P17A YARD-3022

SOTR NO	GT61410014M/A
REV. NO.	03
DATE	10.07.2023
PAGE NO.	Page 16 of 32

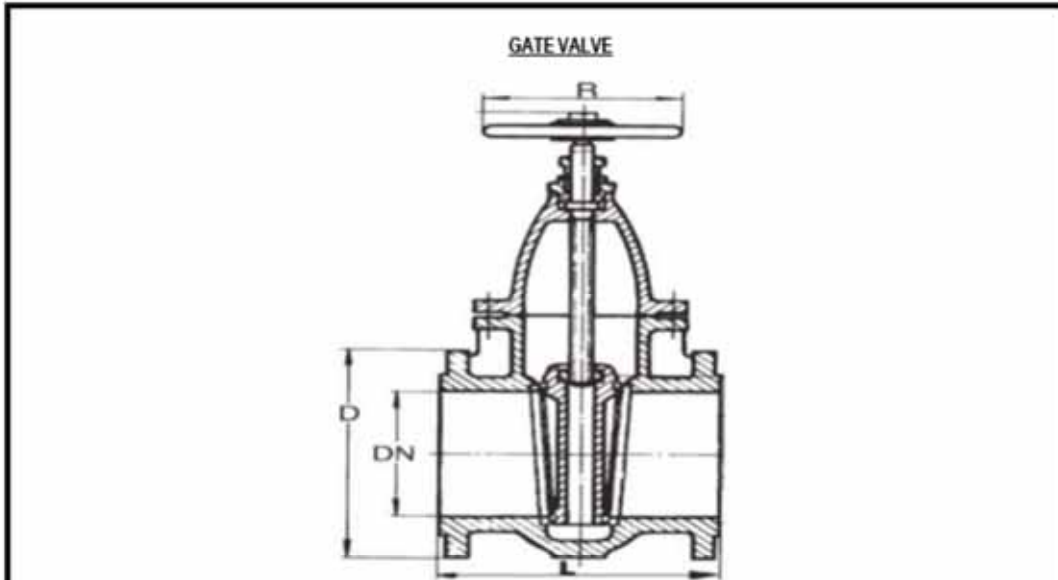

***NOTE:**

Drawings attached in SOTR are for reference and clear understanding of valve only

**FACE-TO-FACE DISTANCE
GATE VALVE DIMENSIONS**

L-VALVE FLANGE FACE TO FACE DIMENSIONS (Inclusive of FLANGE THICKNESS)

SR. NO.	NOMINAL SIZE	DIMENSIONS	END CONNECTION DETAILS	QTY. / SYSTEM	TOTAL QTY.
		L			
01	50	178	FLANGED		
02	65	190	FLANGED		
03	80	203	FLANGED		
04	100	229	FLANGED		
05	125	254	FLANGED		
06	150	267	FLANGED		
07	200	292	FLANGED		
08	250	330	FLANGED		
09	300	356	FLANGED		
10	350	381	FLANGED		



 GRSE LTD. (A Govt. of India Undertaking) 43/46 Garden Reach Road, Kolkata - 700024	STATEMENT OF TECHNICAL REQUIREMENT FOR RE-SIZING / REFURBISHMENT OF VALVES	SOTR NO	GT61410014M/A
		REV. NO.	03
		DATE	10.07.2023
		PAGE NO.	Page 17 of 32
PROJECT-P17A YARD-3022			

VALVE DATA SHEET					
NICKEL ALUMINIUM BRONZE SWING CHECK VALVE					
1	GENERAL SPECIFICATION				
1.1	FLUID HANDLED	SEAWATER/BILGES	1.7	BORE TYPE	FULL BORE
1.2	OP. PRESSURE	10 Kg/Cm ²	1.8	END CONN.	FLANGED
1.3	OP. TEMPERATURE.	120 °C MAX.	1.9	FACE-TO-FACE DIST.	REFER DATASHEET
1.4	SIZE RANGE	REFER DATASHEET	1.10	FLANGE FACE	BS4504-3.3(RAISED FACE)
1.5	MATING PIPE SPECN.	90-10 Cu-Ni as per NES 779 Part III	1.11	BODY TYPE	SINGLE PIECE
1.6	VALVE REF. DOC.	NES375/BS 5352/BS 1868	1.12	VALVE OPERATION	N. A
2	MATERIAL SPECIFICATION				
	PART	MATERIAL	SPECIFICATION		
2.1	BODY	NICKEL ALUMINIUM BRONZE	NES 747 PART II		
2.2	COVER	NICKEL ALUMINIUM BRONZE	NES 747 PART II		
2.3	DISC	NICKEL ALUMINIUM BRONZE (SOLID)	NES 747 PART II		
2.4	SEAT RING	NICKEL ALUMINIUM BRONZE	NES 747 PART II		
2.5	DISC RETAINING NUT & PIN	NICKEL ALUMINIUM BRONZE	NES 862		
2.6	HINGE	NICKEL ALUMINIUM BRONZE	NES 747 PART II		
2.7	HINGE PIN	NICKEL ALUMINIUM BRONZE	NES 833 PART II		
2.8	SOFT SEAT	REINFORCED PTFE			
2.9	COVER SEAL	ASBESTOS FREE	BS 7531		
2.10	BOLTS	NICKEL ALUMINIUM BRONZE	NES 862		
2.11	NUTS	NICKEL ALUMINIUM BRONZE	NES 862		
2.12	TAB WASHER	STAINLESS STEEL	IS 8062 / ASTM A 240 Gr. 304		
3	STATUTORY REQUIREMENTS				
3.1	PAINTING/ SURFACE FINISH	SMOOTH SURFACE WITH METAL FINISH			
3.2	INSPECTION & TESTING	API 598			
3.3	TESTING HYDROSTATIC	AS PER BS 6755 PART I for RATE 'A'			
3.4	LOW PRESSURE TEST	15 psi			
3.5	HYDROSTATIC TEST PRESSURE	BODY - 15 BAR SEAT - 11 BAR			
3.6	PNEUMATIC TEST PRESSURE	7 BAR WITH VALVE CLOSED CONDITION			
3.7	PRESSURE DROP TEST/FLOW MEASUREMENT TEST	ACROSS VALVE			
3.8	ANTISTATIC TEST	AS PER BS 5146 (* IF APPLICABLE)			
3.9	RUBBER BONDING TESTING	ASTM D 429			
3.10	REPEATABILITY TEST	25 CYCLE MINIMUM FOLLOWED BY HYDROTEST			
3.11	CERTIFICATION	GRSE(QA)/TPIA			
3.12	INSPECTION	GRSE(QA)/TPIA			
NOTE:-THE VALVE FLAP SHALL OPEN AT MINIMUM OF 0.5 BAR PRESSURE.					



	GRSE LTD. (A Govt. of India Undertaking) 43/46 Garden Reach Road, Kolkata - 700024	STATEMENT OF TECHNICAL REQUIREMENT FOR RE-SIZING / REFURBISHMENT OF VALVES		SOTR NO	GT61410014M/A
				REV. NO.	03
				DATE	10.07.2023
		PROJECT-P17A YARD-3022		PAGE NO.	Page 18 of 32

VALVE DATA SHEET					
GUN METAL SWING CHECK VALVES					
1	GENERAL SPECIFICATION				
1.1	FLUID HANDLED	F.W, FO, LO, AVCAT & C W	1.7	BORE TYPE	FULL BORE
1.2	OP. PRESSURE	10 Kg/Cm ²	1.8	END CONN.	FLANGED
1.3	OP. TEMPERATURE.	120 °C MAX.	1.9	FACE-TO-FACE DIST.	REFER DATASHEET
1.4	SIZE RANGE	REFER DATASHEET	1.10	FLANGE FACE	BS4504-3.3(RAISED FACE)
1.5	MATING PIPE SPECN.	90-10 Cu-Ni /ASTM A 106 GR B	1.11	BODY TYPE	SINGLE PIECE
1.6	VALVE REF. DOC.	NES375/BS 5352/BS1868	1.12	VALVE OPERATION	N. A
2	MATERIAL SPECIFICATION				
	PART	MATERIAL	SPECIFICATION		
2.1	BODY	GUNMETAL	BS 1400 LG 4C		
2.2	COVER	GUNMETAL	BS 1400 LG 4C		
2.3	DISC	NICKEL ALUMINIUM BRONZE (SOLID)	NES PART 747 PART II		
2.4	DISC SEAT	NICKEL ALUMINIUM BRONZE	NES PART 747 PART II		
2.4	SEAT RING	NICKEL ALUMINIUM BRONZE	NES PART 747 PART II		
2.5	DISC RETAINING NUT& PIN	NICKEL ALUMINIUM BRONZE	NES 862		
2.6	HINGE	NICKEL ALUMINIUM BRONZE	NES PART 747 PART II		
2.7	HINGE PIN	NICKEL ALUMINIUM BRONZE	NES 833 PART II		
2.8	SOFT SEAT	REINFORCED PTFE	REINFORCED WITH 90/10 CuNi		
2.9	COVER SEAL	ASBESTOS FREE	BS 7531		
2.10	BOLTS	NICKEL ALUMINIUM BRONZE	NES 862		
2.11	NUTS	NICKEL ALUMINIUM BRONZE	NES 862		
2.12	TAB WASHER	STAINLESS STEEL	IS 8062 / ASTM A 240 Gr. 304		
3	STATUTORY REQUIREMENTS				
3.1	PAINTING/ SURFACE FINISH	SMOOTH SURFACE WITH METAL FINISH			
3.2	INSPECTION & TESTING	API 598			
3.3	TESTING HYDROSTATIC	AS PER BS 6755 PART I for RATE 'A'			
3.4	LOW PRESSURE TEST	15 psi			
3.5	HYDROSTATIC TEST PRESSURE	BODY – 15 BAR SEAT – 11 BAR			
3.6	PNEUMATIC TEST PRESSURE	7 BAR WITH VALVE CLOSED CONDITION			
3.7	PRESSURE DROP TEST/FLOW MEASUREMENT TEST	ACROSS VALVE			
3.8	ANTISTATIC TEST	AS PER BS 5146 (* IF APPLICABLE)			
3.9	RUBBER BONDING TESTING	ASTM D 429			
3.10	REPEATABILITY TEST	25 CYCLE MINIMUM FOLLOWED BY HYDROTEST			
3.11	CERTIFICATION	GRSE(QA)/TPIA			
3.12	INSPECTION	GRSE(QA)/TPIA			
NOTE:-THE VALVE FLAP SHALL OPEN AT MINIMUM OF 0.5 BAR					



 GRSE LTD. (A Govt. of India Undertaking) 43/46 Garden Reach Road, Kolkata - 700024	STATEMENT OF TECHNICAL REQUIREMENT FOR RE-SIZING / REFURBISHMENT OF VALVES	SOTR NO	GT61410014M/A
		REV. NO.	03
		DATE	10.07.2023
		PAGE NO.	Page 19 of 32
PROJECT-P17A YARD-3022			

SWING CHECK VALVE

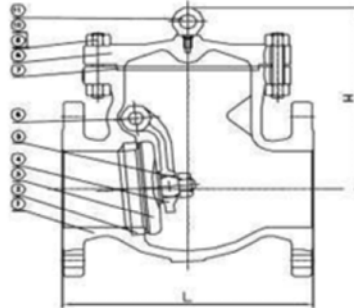

NOMENCLATURE

NO.	PART DESCRIPTION	NO.	PART DESCRIPTION
1	BODY	7	GASKET
2	SEAT	8	BONNET
3	DISC	9	BOLT
4	HINGE	10	NUT
5	NUT	11	EYEBOLT
6	PIN		

***NOTE:**

Drawings attached in SOTR are for reference and clear understanding of valve only

**FACE-TO-FACE DISTANCE
CHECK VALVE DIMENSIONS**

L-VALVE FLANGE FACE TO FACE DIMENSIONS (Inclusive of FLANGE THICKNESS)

SR. NO.	NOMINAL SIZE	DIMENSIONS L	END CONNECTION DETAILS	QTY. / SYSTEM	TOTAL QTY.
01	25	127			
02	32	146			
03	40	165			
04	50	203			
05	65	216			
06	80	241			
07	100	292			
08	125	330			
09	150	356			
10	200	495			
11	250	622			
12	300	698			



	GRSE LTD. (A Govt. of India Undertaking) 43/46 Garden Reach Road, Kolkata - 700024	STATEMENT OF TECHNICAL REQUIREMENT FOR RE-SIZING / REFURBISHMENT OF VALVES		SOTR NO	GT61410014M/A
				REV. NO.	03
				DATE	10.07.2023
		PROJECT-P17A YARD-3022		PAGE NO.	Page 20 of 32

VALVE DATA SHEET					
NICKEL ALUMINIUM BRONZE PRESSURE REDUCING VALVE					
1	GENERAL SPECIFICATION				
1.1	FLUID HANDLED	SW/BILGES	1.7	BORE	FULL BORE
1.2	OP. PRESSURE	10 Kg/Cm ²	1.8	END CONN.	FLANGED
1.3	OP. TEMPERATURE.	120 °C MAX.	1.9	FACE-TO-FACE DIST.	REFER DATASHEET
1.4	SIZE RANGE	REFER DATASHEET	1.10	FLANGE FACE	BS4504-3.3(RAISED FACE)
1.5	MATING PIPE SPECN.	90-10 Cu-Ni / COPPER (BS2871-II)	1.11	BODY TYPE	SINGLE PIECE
1.6	VALVE REF. DOC.	NES 360 /API 527/ASME PTC25	1.12	VALVE OPERATION	SPRING LOADED
2	MATERIAL SPECIFICATION				
	PART	MATERIAL	SPECIFICATION		
2.1	BODY	NICKEL ALUMINIUM BRONZE	NES 747 PART II		
2.2	BONNET	NICKEL ALUMINIUM BRONZE	NES 747 PART II		
2.3	BODY SEAT	NICKEL ALUMINIUM BRONZE	NES 747 PART II		
2.4	SPINDLE	NICKEL ALUMINIUM BRONZE	NES 833 PART II		
2.5	SPRING	SPRING STEEL	IS 4454		
2.6	SPINDLE NUT	NICKEL ALUMINIUM BRONZE	NES 833 PART II		
2.7	SEAT SECURING SCREW	NICKEL ALUMINIUM BRONZE	NES 833 PART II		
2.8	WASHER	NICKEL ALUMINIUM BRONZE	NES 833 PART II		
2.9	PISTON	NICKEL ALUMINIUM BRONZE	NES 833 PART II		
2.10	BOLTS	NICKEL ALUMINIUM BRONZE	NES 862		
2.11	NUTS	NICKEL ALUMINIUM BRONZE	NES 862		
2.12	TAB WASHER	STAINLESS STEEL	IS 8062/ ASTM A 240 Gr. 304		
3	STATUTORY REQUIREMENTS				
3.1	PAINTING/ S. TREATMENT	SMOOTH SURFACE WITH METAL FINISH			
3.2	TESTING HYDROSTATIC	AS PER API527			
3.3	HYDROSTATIC TEST PRESSURE	BODY – 15 BAR SEAT – 11 BAR			
3.4	PNEUMATIC TEST PRESSURE	7 BAR			
3.5	LIFE CHARACTERISTICS	CHECK LINEARITY, ACCURACY, REPEATABILITY & HYSTERESIS			
3.6	VALVE COEFFICIENT	AS INDICATED IN APPROVED DRAWING			
3.7	CERTIFICATION	GRSE(QA)/TPIA			
3.8	INSPECTION	GRSE(QA)/TPIA			



GRSE LTD.
(A Govt. of India Undertaking)
43/46 Garden Reach Road,
Kolkata - 700024

**STATEMENT OF TECHNICAL
REQUIREMENT FOR RE-SIZING /
REFURBISHMENT OF VALVES**

PROJECT-P17A YARD-3022

SOTR NO GT61410014M/A

REV. NO. 03

DATE 10.07.2023

PAGE NO. Page 21 of 32

Pressure Reducing Valve

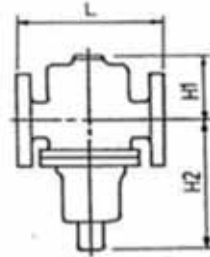

Valve Diameter (mm)	Dimensions (mm)		
	L	H1	H2
15	158	76	155
20	174	92	162
25	177	92	162
32	212	100	237
40	280	148	290
50	304	174	354
65	305	165	412
80	305	162	536
100	406	222	655
125	460	240	675
150	508	248	672

***NOTE:**

Drawings attached in SOTR are for reference and clear understanding of valve only



 GRSE LTD. (A Govt. of India Undertaking) 43/46 Garden Reach Road, Kolkata - 700024	STATEMENT OF TECHNICAL REQUIREMENT FOR RE-SIZING / REFURBISHMENT OF VALVES PROJECT-P17A YARD-3022	SOTR NO	GT61410014M/A
		REV. NO.	03
		DATE	10.07.2023
		PAGE NO.	Page 22 of 32

GM LOOSE RING FLANGE
 [For pipes formed by Flanging Machine]

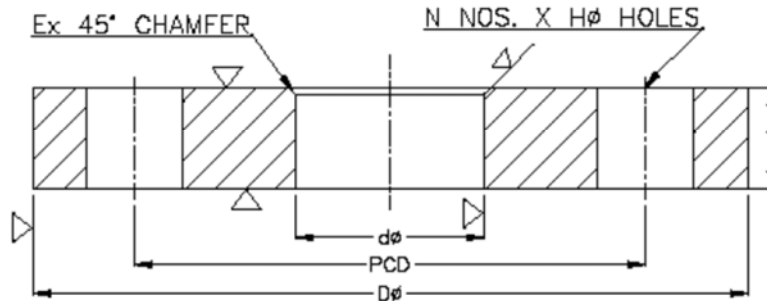

NB	PIPE OD	dØ	DØ	PCD	T	E	NxHØ	GASKET OD/IDØ	QTY	MATERIAL CODE
20	25.0	27.5	105	75	15	2	4X14	105/22	AS PER INDENT	485433091502
25	30.0	32.5	115	85	16	2	4X14	115/27		485433091602
32	36.0	40.5	140	100	16	2	4X18	140/35		485433091702
40	44.5	47.0	150	110	16	2	4X18	150/41.5		485433091802
50	57.0	59.5	165	125	16	3	4X18	165/54		485433091902
65	76.1	79.0	185	145	16	3	4X18	185/72		485433092502
80	88.8	92.0	200	160	18	3	8X18	200/83.9		485433092602
100	108.0	111.5	220	180	18	3	8X18	220/103		485433093002
125	133.1	136.5	250	210	19	3	8X18	250/128		485433093302
150	159.0	162.5	285	240	21	3	8X22	285/152		485433093702
200	219.1	222.5	340	295	25	3	8X22	340/213		485433094102

NOTES:-

1. MATERIAL- GM TO BS 1400 LG 4C.
2. ALL DIMENTION ARE IN MM.
3. MAXIMUM WORKING PRESSURE-10 BAR.
4. FLANGES ARE TO SUBJECTED TO DP TEST AFTER MACHINING.
5. THE FLANGES ARE TO CONFIRM ALL REQUIREMENTS OF BS4504 SECTION 3.3 CODE 301 AND PN. 10 RATING.
6. ASBESTOS FREE GASKET TO BE SUPPLIED BY GRSE.
7. FOLOWING TOLERANCES WILL APPLY ON ALL DIMENSION EXCEPT 'dØ':
 - a) UPTD 30 MM: ±0.20MM
 - b) ABOVE 30 MM TO 120 MM: ±0.30MM
 - c) ABOVE 120M TO 315MM: ±0.50MM
 - d) ABOVE 315MM TO 1000MM: ±0.80MM
8. FOLLOWING TOLERANCES WILL APPLY ON 'dØ' ONLY
 - a) UPTO 50 MM: $\begin{matrix} +0.2 \\ 0 \end{matrix}$ MM
 - b) ABOVE 50 MM TO 100MM: $\begin{matrix} +0.30 \\ 0 \end{matrix}$ MM
 - c) ABOVE 100 MM TO 250MM: $\begin{matrix} +0.4 \\ 0 \end{matrix}$ MM



GRSE LTD.
(A Govt. of India Undertaking)
43/46 Garden Reach Road,
Kolkata - 700024

STATEMENT OF TECHNICAL
REQUIREMENT FOR RE-SIZING /
REFURBISHMENT OF VALVES
PROJECT-P17A YARD-3022

SOTR NO	GT61410014M/A
REV. NO.	03
DATE	10.07.2023
PAGE NO.	Page 23 of 32

FGN TYPE GM FLANGE
(FROM 250NB-400NB)

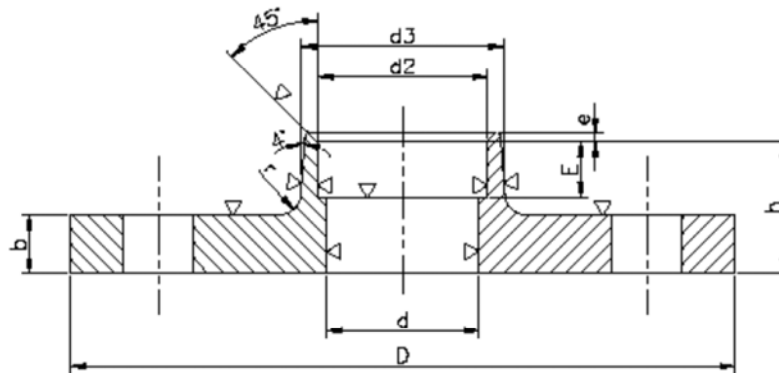

NOM SIZE	FLANGE									BOLTING HOLES			BOLT SIZE	QTY	MATERIAL CODE
	d	D	b	E	h	d3	r	d2	a	No	DIA	PCD			
250	261	395	26	26	48	285	10	268.13	3	12	22	350	M20	AS PER INCIDENT	485404094301
300	315.9	445	26	26	50	338	10	325.03	3	12	22	400	M20		485404094401
350	360	505	26	26	50	386	10	369.13	3	16	22	460	M20		485404094601
400	411.0	565	26	26	52	445	10	420.13	3	16	26	515	M24		485404094501

NOTES:-

1. MATERIAL- GM TO BS 1400 LG 4G.
2. ALL DIMENTION ARE IN MM.
3. MAXIMUM WORKING PRESSURE-10 BAR.
4. FLANGES ARE TO SUBJECTED TO DP TEST AFTER MACHINING.
5. THE FLANGES ARE TO CONFIRM ALL REQUIREMENTS OF BS4504 SECTION 3.3 AND PN. 10 RATING.
6. TOLERANCE ON 'd2' AS PER BS 4504, SEC 3.3, TABLE-12
7. FOLLOWING TOLERANCES WILL APPLY ON 'd ϕ ' ONLY
 - a) ABOVE 250 MM TO 450MM: ± 0.45 MM



	GRSE LTD. (A Govt. of India Undertaking) 43/46 Garden Reach Road, Kolkata - 700024	STATEMENT OF TECHNICAL	SOTR NO	GT61410014M/A
		REQUIREMENT FOR RE-SIZING /	REV. NO.	03
		REFURBISHMENT OF VALVES	DATE	10.07.2023
		PROJECT-P17A YARD-3022	PAGE NO.	Page 24 of 32

Annexure-I

SURPLUS VALVE LIST

<u>SL</u>	<u>ITEMS</u>	<u>QTY</u>	<u>WEIGHT (APPX)</u>
1	Various size of Valve (15 NB to 125 NB)	40	300 KG
2	200 NB Diaphragm Valve	11	1870 KG
3	200 NB Gate Valve	5	375 KG
4	200 NB Right Angle SDNR	1	165 KG
5	200 NB Globe Valve	2	380 KG
6	250 NB Globe Valve	2	420 KG
7	300 NB B/F	2	160 KG
8	250 NB B/F	1	90 KG
9	150 NB Right Angle	2	180 KG
10	400 NB B/F	3	420 KG
11	125 NB Globe Valve	3 (SDNR) + 1 (Gate Valve)	320 KG
12	150 NB Strainer	1	105 KG
13	200 NB BF	1	70 KG
14	125 NB Diaphragm Valve	1	80 KG
15	200 NB Diaphragm Valve	4	680 KG
16	400 NB Butterfly Valve	8	1120 KG
17	200 NB PRS Valve	1	140 KG



	GRSE LTD. (A Govt. of India Undertaking) 43/46 Garden Reach Road, Kolkata - 700024	STATEMENT OF TECHNICAL REQUIREMENT FOR RE-SIZING / REFURBISHMENT OF VALVES		SOTR NO	GT61410014M/A
				REV. NO.	03
				DATE	10.07.2023
		PROJECT-P17A YARD-3022		PAGE NO.	Page 25 of 32

ANNEXURE-II

LIST OF VALVES TO BE MANUFACTURED

S/L	SHORT TEXT	QTY
1	100 NB BUTTERFLY VALVE, NAB, FLANGED	10
2	150 NB BUTTERFLY VALVE, GM, LUG	5
3	150 NB BUTTERFLY VALVE, NAB, FLANGED	4
4	100 NB BUTTERFLY VALVE, NAB, LUG	4
5	150NB BUTTERFLY VALVE, NAB, LUG	50
6	200 NB BUTTERFLY VALVE, NAB, LUG	15
7	250 NB BUTTERFLY VALVE, NAB, FLANGED	2
8	350 NB BUTTERFLY VALVE, NAB, FLANGED	3
9	100 NB, DIAPHRAGM VALVE, NAB	2
12	150 NB NR SWING/CHECK VALVE, GM	2
13	150 NB NR SWING/CHECK VALVE, NAB	10
14	200 NB NR SWING/CHECK VALVE, NAB	10
15	250 NB NR SWING/CHECK VALVE, NAB	2
16	200 NB GATE VALVE, NAB	5
17	250 NB, GATE VALVE, NAB	5
18	350NB, GATE VALVE, NAB	2
20	150 NB, PRESSURE REDUCING VALVE, NAB	2
21	100 NB SDNR VALVE, ANGLE, FLANGED, NAB	10
22	GM FLANGES UPTO TOTAL WEIGHT 500 KG COMPRISING VARIOUS SIZES AS PER SOTR (OPTIONAL)	To be finalized post placement of order
	Total=	143 valves



	GRSE LTD. (A Govt. of India Undertaking) 43/46 Garden Reach Road, Kolkata - 700024	STATEMENT OF TECHNICAL REQUIREMENT FOR RE-SIZING / REFURBISHMENT OF VALVES	
		SOTR NO	GT61410014M/A
		REV. NO.	03
		DATE	10.07.2023
PROJECT-P17A YARD-3022		PAGE NO.	Page 26 of 32

ANNEXURE-III

<u>CERTIFICATE OF CONFORMITY</u>	
(To be filled in by the SUPPLIER & submitted as part of the Offer)	
M/s _____	
With reference to the subject Requisition received along with the GARDEN REACH SHIPBUILDERS & ENGINEERS LTD. Inquiry and our QUOTATION No. _____ Dated _____ we hereby confirm / clarify the following :	
1.	REGISTRATION WITH DQA(WP) / DQA (N) /GARDEN REACH SHIPBUILDERS & ENGINEERS LTD : We are <u>NOT Registered/already REGISTERED</u> (*) with _____ for manufacture and supply of following items (REG NO: _____) (a) _____ (b) _____
2.	PAST PERFORMANCE : We have <u>NOT Supplied/have SUPPLIED</u> (*) <u>identical/similar</u> (*) ITEM to GRSE in the past. The relevant Order references are given below : (a) _____ (b) _____
3.	REQUISITION / DRAWINGS / SPECIFICATIONS / SOR : We <u>ARE NOT/ARE</u> (*) fully aware of the relevant Drawings / Specifications / SOR etc. indicated in the REQUISITION and the related Documents.
4.	DEVIATION : The OFFER is fully in compliance with the Requisition <u>WITHOUT any deviation/EXCEPT for the deviations listed in the attached format</u> (*).
5.	BINDING DATA : OUR Drawings with necessary BINDING DATA such as Overall Dimensions, SEATING Details / Bolting Plan, Connection / Interface Details, Face to Face Dimensions is <u>ENCLOSED/NOT Enclosed</u> (*) with the offer. We have noted that any change in Binding Data shall require specific approval from GRSE/INDIAN NAVY.
6.	DOCUMENTS / DATA : The following Technical Documents / DATA SHEETS are enclosed herewith (a) (To be specified if applicable)
For M/s _____	
Signature : _____ Date : _____	
Stamp :	
(*) Strike out which is NOT APPLICABLE	
NOTE: VENDOR TO SUBMIT DGQA REGISTRATION CERTIFICATE ALONG WITH THIS FORM	



 GRSE LTD. (A Govt. of India Undertaking) 43/46 Garden Reach Road, Kolkata - 700024	STATEMENT OF TECHNICAL REQUIREMENT FOR RE-SIZING / REFURBISHMENT OF VALVES		SOTR NO GT61410014M/A
	PROJECT-P17A YARD-3022	REV. NO. 0	DATE 20.05.2023
			PAGE NO. Page 28 of 32

ANNEXURE-V

Vendor Name & Address		Item(s): Line Valves	QAP No:	Rev: 01	Date:	Page:	
		GRSE PO No(s):	P- Perform; W- Witness by TPIA; V- Verification; CHP- Customer Hold Point; VI-Visual Inspection; DI- Dimensional Inspection, TC- Tests certificate from NABL accredited Lab;				
		SOTR/ TSP No:	CC- Compliance Certificate, IR- Inspection Report				
Sl. No.	Process / Activity	Qty. & Size: As per PO(s)	Acceptance Criteria	Quantum of check	Inspection record format	Inspection Agency	
		Characteristics to be verified				Firm/ Vendor	
						Remarks	
1	RAW MATERIAL INSPECTION:						
1.1	Casting of Valve components: Body, bonnet, disc, cover		As per relevant standard/ SOTR & approved drawings	Every Batch/lot	Mill TC/ NABL TC	P	R
		a) Chemical analysis of Ingot	TSP/ SOTR/ Approved drawing	100 %	IR	P	W
		b) Pouring	TSP/SOTR. Approved Drawings	100%	IR	P	W
		c) Material Identification & Stamping	HT Chart	100%	IR	P	R
		d) Heat Treatment					
							Raw material stock verification by TPIA. The ingot should be poured from virgin material only. Pouring to be witnessed by TPIA, samples to be stamped by TPIA for testing at NABL acc. Lab.
							Not applicable for Gun Metal.



 GRSE LTD. (A Govt. of India Undertaking) 43/46 Garden Reach Road, Kolkata - 700024	STATEMENT OF TECHNICAL REQUIREMENT FOR RE-SIZING / REFURBISHMENT OF VALVES			SOTR NO	GT61410014M/A
				REV. NO.	0
				DATE	20.05.2023
				PAGE NO.	Page 29 of 32
PROJECT-P17A YARD-3022					

Sl. No.	Process / Activity	TSP/SOTR. Approved Drawings	One sample/ heat	TC from NABL Acc. Lab	P	R	Inspection Agency	
							Firm/ Vendor	TPIA
	e) Chemical analysis & Mechanical Properties	TSP/SOTR. Approved Drawings	One sample/ heat	TC from NABL Acc. Lab	P	R		Inspection Agency
	f) Dressing of casting	Relevant standards, SOTR	100%	IR	P	R		Remarks
	g) Permanent Marking on Body (Direction of flow, Nominal Dia, Pressure Rating, Firm monogram, Date of Mfg.)	TSP/SOTR. Approved Drawings	100%	IR	P	R		
1.2	Forged / Rolled Components of Valve - Stem	TSP/SOTR. Approved Drawings	03 samples/ batch/lot	TC from NABL Acc. Lab	P	R		<p>*Three test specimens per batch/lot shall be made. Retest to be carried out on two further specimens in the event of failure of initial specimen. (Applicable only for forged parts)</p> <p>Firm should submit HT Charts for every heat / lot. AB2 bars HT report, however, MOC indicated is subject to Design acceptance.</p>

	GRSE LTD. (A Govt. of India Undertaking) 43/46 Garden Reach Road, Kolkata - 700024	STATEMENT OF TECHNICAL REQUIREMENT FOR RE-SIZING / REFURBISHMENT OF VALVES		SOTR NO		GT61410014M/A			
		PROJECT-P17A YARD-3022		REV. NO.	0				
		DATE		20.05.2023		PAGE NO.		Page 30 of 32	

Sr. No	Process / Activity	Chemical & Mechanical Properties	TSP/SOTR. Approved Drawings	01 no./ lot/size	TC from NABL Acc. Lab	Inspection Agency		Samples to be stamped by TPIA & tested in a mutually agreed
						Acceptance Criteria	Inspection record format	
1.3	BROUGHT OUT ITEMS / COTS:							
	a) Fasteners - Studs/Nuts	c) Chemical & Mechanical Properties Characteristics to be verified d) UT (if applicable)	TSP/SOTR. Approved Drawings	Quantum of check 100%	IR / TC/UT Report	P	R	UT to be undertaken by ASNT/ISNT level II or Level III inspectors. (if applicable)
2	IN-PROCESS INSPECTION:							
2.1	Casting of Valve Components -Body, Bonnet, Disc, Cover	Visual, Dimensional Inspection,	Approved Drawings	100%	IR	P	R	
2.2	b) Casting item (if applicable -Body)	l) Radiographic examination (AS shown in approved GAD)	ASME Section V Articles-2 Sub Section ASTM-E272, ANSI-B16.34	100%	RT Report and Radiographs (Film) to be sentenced by the competent authority	P	R	The reference radiographs used for comparison should be indicated by competent authority (ASNT/ISNT level-II or ANST/ ISNT level-III).



GRSE LTD. (A Govt. of India Undertaking) 43/46 Garden Reach Road, Kolkata - 700024		STATEMENT OF TECHNICAL REQUIREMENT FOR RE-SIZING / REFURBISHMENT OF VALVES				SOTR NO		GT61410014M/A	
		PROJECT-P17A YARD-3022				REV. NO.	0	DATE	20.05.2023
						PAGE NO.	Page 31 of 32		
Sl. No.	Process / Activity	Characteristics to be verified	Acceptance Criteria	Quantum of check	Inspection record format	Firm/ Vendor	TPIA	Inspection Agency Remarks	
2.3	c) Forged / Rolled Components of Valve – Stem	i) Visual ii) Dimension iii) Workmanship & Surface finish	TSP/SOTR Approved drawings	100%	TC from NABL Acc. Lab / OEM CoC	P	R		
2.4	d) Forged / Rolled Components of Valve – Stem (If applicable)	i) UT	ASME Section V Article - 5	100%	TC from NABL Acc. Lab / UT Report	P	R	UT to be conducted & examined by competent authority. (If Applicable) CHP	
Sr. No	Process / Activity	Characteristics to be verified	Acceptance Criteria	Quantum of check	Inspection record format	Firm/ Vendor	TPIA	Inspection Agency Remarks	
3	FINAL INSPECTION:								
3.1	Valve Assembly	a) Visual & Dimensional Inspection	As per TSP, approved drawings	100%	IR	P	W		



 GRSE LTD. (A Govt. of India Undertaking) 43/46 Garden Reach Road, Kolkata - 700024	STATEMENT OF TECHNICAL REQUIREMENT FOR RE-SIZING / REFURBISHMENT OF VALVES		SOTR NO	GT61410014M/A
	PROJECT-P17A YARD-3022		REV. NO.	0
			DATE	20.05.2023
			PAGE NO.	Page 32 of 32

	b) Functional Check: i) Hydraulic Test: Body & Seat Test	As per TSP, BS EN 12266 – 1 BS EN 12266 - 2 approved drawings	100%	IR	P	W	Additionally, for Swing Check valves, NR function test at 0.5 bar to be witnessed by TPIA
	c) Fire Safe test (if applicable)	As per TSP, approved drawings	01 no. of each type/size	IR	P	W	Only for valves required as per SOTR.
	c) Weight recording/certification	As per TSP, approved drawings	100%	IR	P	W	Tolerance in weight as per SOTR requirement
	d) Marking Preservation, pre-dispatch inspection & Packing	As per TSP, approved drawings	100%	IR	P	W	
3.2	Submission of approved Documents	As per PO, TSP, Approved Drawings	100%	IR	P	V	

General QA remarks:

1. Raw material stock verification by TPIA. Virgin ingots to be used & co-related ingot TC to be review by TPIA.
2. All test samples to be identified by TPIA. Chemical & Mechanical tests to be done at NABL accredited lab.
3. For brought out items, compliance certificate to be verified by TPIA and doubt if any, TPIA may recommend for counter check.
4. In every stages of inspection, traceability/ identity of the material shall be established & retained. Where it is not possible to preserve the traceability, the testing as recommended by attending rep. of inspection agency, to be undertaken from the finished product, randomly selected from the batch/lot/size. In that case one additional product to be manufactured by the firm.
5. This document to be read in conjunction with SOTR, P.O. and approved drawings to achieve final specification of the product and its acceptance procedure by TPIA.



GARDEN REACH SHIPBUILDERS & ENGINEERS LTD.

गार्डन रीच शिपबिल्डर्स एण्ड इंजीनियर्स लिमिटेड

(A GOVERNMENT OF INDIA UNDERTAKING) / (भारत सरकार का प्रतिष्ठान)

Address: 61, Garden Reach Road, Kolkata-700 024 61, गार्डन रीच रोड, कोलकाता-700 024

Phone/दूरभाषः:(033) 2469-8140 to 8143, FAXफैक्सः (033) 2469-8144

Web siteवेबः www.grse.in, E-Mailई मेलः Gupta.Manoj@grse.co.in

CIN / सी आई एनः L35111WB1934GOI007891

ANNEXURE-1B: BILL OF QUANTITIES

NIT SLA No / निविदा संख्या:	SCC/NK/NIC/OT/CDO/Valves/019/ET-2018 DTD: 14-Oct-2023
Job Title / कार्य का नाम	RE-SIZING / REFURBISHMENT OF VALVES
SOR No:	GT61410014M/A Rev.03 dt. 10.07.23 (Annexure-1A)
Tender issuing Dept. / बिभाग द्वारा जारी	Contract Cell (संविदा बिभाग)

- (a) BOQ for the work is detailed below.
- (b) Any of the Line item may be deleted as per actual requirement of GRSE. Necessary amendment of the Purchase Orders will be issued accordingly (if required).
- (c) Detailed price breakup indicating **GST HSN/SAC Code & Percentage** as per this BoQ is to be uploaded in Portal along with price offer (Part II).

BOQ is as follows:

Sl. No	Description	UOM	Qty.	Rate (INR)	Amount Excluding GST (INR)	GST HSN/SAC Code	GST%	GST Amount (INR)	Amount Including GST (INR)
1	100 NB BUTTERFLY VALVE, NAB, FLANGED	EA	10						
2	150 NB BUTTERFLY VALVE, GM, LUG	EA	5						
3	150 NB BUTTERFLY VALVE, NAB, FLANGED	EA	4						
4	100 NB BUTTERFLY VALVE, NAB, LUG	EA	4						
5	150NB BUTTERFLY VALVE, NAB, LUG	EA	50						
6	200 NB BUTTERFLY VALVE, NAB, LUG	EA	15						
7	250 NB BUTTERFLY VALVE, NAB, FLANGED	EA	2						
8	350 NB BUTTERFLY VALVE, NAB, FLANGED	EA	3						
9	100 NB, DIAPHRAGM VALVE, NAB	EA	2						
12	150 NB NR SWING/CHECK VALVE, GM	EA	2						
13	150 NB NR SWING/CHECK VALVE, NAB	EA	10						
14	200 NB NR SWING/CHECK VALVE, NAB	EA	10						



Sl. No	Description	UOM	Qty.	Rate (INR)	Amount Excluding GST (INR)	GST HSN/SAC Code	GST%	GST Amount (INR)	Amount Including GST (INR)
15	250 NB NR SWING/CHECK VALVE, NAB	EA	2						
16	200 NB GATE VALVE, NAB	EA	5						
17	250 NB, GATE VALVE, NAB	EA	5						
18	350NB, GATE VALVE, NAB	EA	2						
20	150 NB, PRESSURE REDUCING VALVE, NAB	EA	2						
21	100 NB SDNR VALVE, ANGLE, FLANGED, NAB	EA	10						
22	GM FLANGES UPTO TOTAL WEIGHT 500 KG COMPRISING VARIOUS SIZES AS PER SOTR (Note: RATE ONLY)	EA	200						
TOTAL									

Note:

EA: EACH

The item 22 is Rate Only and the quantity shall be operated on requirement. The quantity shall be specified at a later date and necessary amendment in PO shall be done accordingly.

WDC shall be issued and Payment shall be considered against receipt & acceptance of actual number of items at GRSE. No stage payment shall be considered.

Unpriced copy of the Price breakup indicating the GST SAC/HSN Code & GST percentage is to be uploaded alongwith the Techno-commercial offer (Part-I).

The bid shall not be considered if Price is indicated in any part of Techno-commercial offer (Part-I).

L1 offer shall be evaluated on TOTALITY BASIS EXCLUDING GST.



GARDEN REACH SHIPBUILDERS & ENGINEERS LTD.

गार्डन रीच शिपबिल्डर्स एण्ड इंजीनियर्स लिमिटेड

(A GOVERNMENT OF INDIA UNDERTAKING) / (भारत सरकार का प्रतिष्ठान)

Address: 61, Garden Reach Road, Kolkata-700 024 61, गार्डन रीच रोड, कोलकाता-700 024

Phone/दूरभाषः:(033) 2469-8140 to 8143, FAXफैक्सः (033) 2469-8144

Web siteवेबः www.grse.in, E-Mailई मेलः Gupta.Manoj@grse.co.in

CIN / सी आई एनः L35111WB1934GOI007891

ANNEXURE 1C: PAYMENT TERMS

NIT SLA No / निविदा संख्या:	SCC/NK/NIC/OT/CDO/Valves/019/ET-2018 DTD: 14-Oct-2023
Job Title / कार्य का नाम	RE-SIZING / REFURBISHMENT OF VALVES
SOR No:	GT61410014M/A Rev.03 dt. 10.07.23 (Annexure-1A)
Tender issuing Dept. / बिभाग द्वारा जारी	Contract Cell (संविदा बिभाग)

1. Payment Terms भुगतान की शर्तें:

- 90% (Ninety percent) of the value of work done will be paid progressively against R/A bill supported with Work Done Certificate. Maximum of 01 (one) R/A Bill shall be accepted per month.
- 10% (Ten percent) of the certified value of work shall be retained as Performance Guarantee and shall be released on:

Completion of the Guarantee period / defect liability period subject to satisfactory liquidation of defects duly certified by Bill Certifying Authority.

OR

Submission of performance Bank Guarantee of equivalent amount valid till expiry of Guarantee period.

For release of this remaining percentage i.e. retention money (if any) either after guarantee period or on submission of PBG; work done certificate shall not be required. While releasing PBG after expiry of guarantee period, the PBG release application to be submitted to Contract Cell duly certified by Bill Certifying Authority.

- Recoverable from contractor, if any, is to be adjusted from respective stage payments as per certification of Bill Certifying Authority.
- Moreover, release of payment is subject to clearance of ESI / P.F and other labour oriented mandatory liabilities of the Contractor.

2. Bill Certifying Authority बिल प्रमाणन प्राधीकर:

AGM(Eng)/FOJ / his authorised representatives.

3. Bill Submission बिल प्रस्तुति:

- Invoice is to be raised after issue of Work Done / Completion Certificate.
- WDC shall be issued against receipt & acceptance of actual number of items at GRSE. No stage payment shall be considered
- Bills are to be submitted along with supporting documents (Work Done Certificate etc.) at the Bill Receiving Counters located at the respective units of Company. Bill is to be submitted (in 03 copies) in sealed envelope super-scribing on the envelope the Purchase Order No., Vendor code, Bill / Invoice No., Name of person /employee to whom bill is addressed, for processing. The Name of the person to be mentioned on sealed envelope will be the Bill certifying officer.

Note: Transaction fee of Rs. 500.00 for first return & Rs. 1000.00 for subsequent return of bill with inappropiate documents will be charged.



GARDEN REACH SHIPBUILDERS & ENGINEERS LTD.

गार्डन रीच शिपबिल्डर्स एण्ड इंजीनियर्स लिमिटेड

(A GOVERNMENT OF INDIA UNDERTAKING) / (भारत सरकार का प्रतिष्ठान)

Address: 61, Garden Reach Road, Kolkata-700 024 61, गार्डन रीच रोड, कोलकाता-700 024

Phone/दूरभाषः:(033) 2469-8140 to 8143, FAXफैक्सः (033) 2469-8144

Web siteवेबः www.grse.in, E-Mailई मेलः Gupta.Manoj@grse.co.in

CIN / सी आई एनः L35111WB1934GOI007891

ANNEXURE -2: STANDARD TERMS & CONDITIONS (STAC)

मानक निबंधन और शर्तें (एसटीएसी)

ANNEXURE -2: STANDARD TERMS & CONDITIONS (STAC) मानक निबंधन और शर्तें (एसटीएसी)

STC 1 Integrity Pact / समग्रता अनुबंध (For the value of Contract more than Rs.2.0 Cr.)

- STC 1.1. All the participating vendors in this tender are required to enter into agreement by signing an Integrity Pact.
- STC 1.2. "The Pact essentially envisages as agreement between the prospective vendors/bidders and the buyer, committing the persons/officials of both the parties, not to exercise any corrupt influence on any aspect of the contract".
- STC 1.3. Signing of Integrity Pact will be preliminary qualification for participation of this tender, only those vendors who have entered into this Pact with GRSE will qualify for the contract. This Integrity Pact will be effective from the stage of invitation of bids till the date of complete execution of this contract.
- STC 1.4. Signing Authority for Integrity Pact:
- STC. 1.4.1. Vendor: Proprietor / Director / Authorized representative
- STC. 1.4.2. GRSE: Head of the Ordering Department, not below the rank of DGM / AGM
- STC 1.5. Vendors need to sign on each page of the Integrity Pact document and provide the same on a Govt. issued bond paper of Rs.100/-. The scanned copy of the same need to be uploaded along with the technical Bid documents and original copy of the same to be forwarded to Tendering Department before the due date of the tender.
- STC 1.6. The vendor has to submit Integrity Pact as per GRSE Format along with Techno-commercial bid, wherever applicable as per NIT.

STC 2 Micro & Small Enterprise (सूक्ष्म और छोटे उद्यम)

- STC 2.1. Purchase preference will be given to eligible Micro and Small Enterprise firms as per MSME Act on submission of valid Udyam Registration Certificate (URC) or NSIC copy along with their offer to claim the benefit. Tenders Service is to be listed in the URC or NSIC submitted else they are disqualified to avail the benefit.
- STC 2.2. Out of 25% target of annual procurement from MSEs, 4% (within the 25%) reservation will be provided for MSEs owned by Schedule Caste (SC) /Scheduled Tribe (ST) entrepreneurs and 3% (within the 25%) reservation will be provided for MSEs owned by women entrepreneurs. Necessary documents to be submitted along with the techno-commercial bid as evidence failing which benefit shall not be accorded. However, in the event of failure of such MSEs to participate in the tender process or meet the tender requirements and L1 price, 4% reservation for MSEs owned by SC/ST entrepreneurs and 3% reservation for MSEs owned by women entrepreneurs will be met from other MSEs.
- STC 2.3. Following facilities/benefits may be given to MSEs: -
- STC. 2.3.1. Exemption for payment of Tender Fee & Earnest Money Deposit.
- STC. 2.3.2. Relaxation in prior Turnover and prior Experience Criteria (Specially for Start Ups- Certificate of DIPP is required to Claim the benefit)



STC 2.4.

- STC 2.4.1. MSEs registered with MSME authority as stated above, quoting price within the band of L1 +15% will be allowed to supply a portion of the requirement by bringing down their price to L1 price in a situation where the L1 price is from someone other than MSE. Such MSEs will be allowed to supply at least 25% of total tendered value. To avail this purchase preference, submission of Udyam Registration Certificate /NSIC is mandatory failing which the benefit will not be accorded.
- STC 2.4.2. In case L1 is not an MSE and there is more than one MSE within the range of L1 +15%, only the lowest MSE shall be considered for 25% order in case of divisible item or 100% in case the order quantity is not divisible, subject to matching the L1 prices.
- STC 2.4.3. If the lowest MSE refuses to accept the L1 price, then the second lowest MSE within the range of L1 +15% will be considered. This process will continue till a MSE in the range accepts the L1 price or the MSEs in the L1 + 15% range are exhausted.
- STC 2.4.4. In case no MSE accepts the L1 price or there is no MSE available in the L1 +15% range, then the order shall be placed to the L1 bidder without applying this principle.
- STC 2.5. Non-Divisibility of Tender Items: - In case of non-divisible / non-splittable item in tenders, an MSE quoting in the price band of L1+15% may be awarded for full/complete supply of total tendered value, considering the spirit of policy for enhancing the government procurement from MSEs subject to matching the L1 prices by the MSE concerned. However, contract will be awarded as per GOI policy and at discretion of GRSE.
- STC 2.6. To qualify for entitlement as SC/ST owned MSE, the SC/ST certificate issued by the District Authority must be submitted along with the offer or the same should be indicated in the relevant document NSIC / Udyam Registration Certificate.
- STC 2.7. For the MSEs owned by SC/ST owned entrepreneur, the benefits as stated above shall be accorded only in the following cases:
- STC 2.7.1. For proprietary MSE, proprietor(s) shall be SC/ST.
- STC 2.7.2. For partnership MSE, the SC/ST partners shall be holding at least 51% shares in the unit.
- STC 2.7.3. For Private Limited Companies, at least 51% share shall be held by SC/ST promoters.

STC 3 Tender Fee (निविदाशुल्क)

- STC 3.1. Amount of declared non-refundable tender fee is to be submitted in the form of Demand Draft / Pay Order, Payable at Kolkata and issued in favour of "Garden Reach Shipbuilders & Engineers Limited" by any Nationalized/Scheduled Bank other than Co-operative Bank. Physical DD/PO to be forwarded to Tendering Department of GRSE within 07 days of tender due date. A scanned copy of the same is to be uploaded as an attachment to the PART-I of e-bid submission.
- STC 3.2. MSE registered firms having the tendered service listed in their MSE document will be eligible for exemption of tender fee. To claim the exemption, a copy of the valid MSE certificate with its annexure is to be scanned and uploaded as an attachment to the PART I of e-bid submission. The same is to be confirmed in the techno-commercial concurrence format.
- STC 3.3. Exemption of Tender Fee is not applicable for JV / Consortium even if all the parties of the JV / Consortium are eligible for such exemption on individual basis.
- STC 3.4. Non-submission of tender fee or a valid MSE certificate may lead to offer rejection.

STC 4 EARNEST MONEY DEPOSIT (INTEREST FREE) बयाना जमा (ब्याज रहित)

- STC 4.1. Amount of declared interest free Earnest Money Deposit (EMD) is to be submitted in form of Demand Draft / Pay Order, Payable at Kolkata and issued in favour of "Garden Reach Shipbuilders & Engineers Limited" by any Nationalized/Scheduled Bank other than Co-operative Bank. Physical DD/PO to be forwarded to Tendering Department of GRSE within 07 days of tender due date. A scanned copy of the same is to be uploaded as an attachment to the PART I e-bid submission.



- STC 4.2. EMD may also be submitted in the form of Bank Guarantee with six months validity as per enclosed GRSE format of Bank Guarantee and is to be forwarded directly to GM (Finance), GRSE in Bankers' sealed envelope failing which same will not be accepted. Details of B.G. are to be in Techno-Commercial part of offer.
- STC 4.3. MSE registered firms having the tendered service listed in their MSE document will be eligible for exemption from submitting EMD. To claim the exemption a copy of the valid MSE certificate with its annexure is to be scanned and uploaded as an attachment to the General Document part of E-PROCUREMENT. The same is to be confirmed in the PART I concurrence format.
- STC 4.4. MSE Registered Firms has to be submit Bid Security Declaration In lieu of Earnest Money Deposit as per GRSE format.
- STC 4.5. Exemption of EMD is not applicable for JV / Consortium even if all the parties of the JV / Consortium are eligible for such exemption on individual basis.
- STC 4.6. Non-submission of EMD /Bid Security Declaration and valid MSE certificate may lead to rejection of offer.

STC 4.7. Refund of Earnest Money Deposits

- STC. 4.7.1. EMD of unsuccessful bidders will be refunded/ returned within 30 days of finalisation of order on surrendering the original copy of GRSE Money Receipt with an application by bidder addressed to HOD of Ordering Department, GRSE on receipt of intimation from GRSE.
- STC. 4.7.2. EMD of disqualified bidders in TNC/CNC will be returned within 30 days from the date of receipt of application along with original copy of Money Receipt from the bidder. EMD, if not claimed within 1 year from the date of notification EMD will be forfeited.
- STC. 4.7.3. EMD of successful bidder will be returned after receipt of security deposit against work order as per contractual terms.
- STC 4.8. **Forfeiture of Earnest Money Deposit** (बयाना जमा की जब्ती): EMD may be forfeited under the following circumstances:

- STC. 4.8.1. The bidder withdraws the bid after opening of Price Bid during the period of validity of offer.
- STC. 4.8.2. The bidder does not accept the correction of error in bid price as indicated in Clause pertaining to **CORRECTION OF ERRORS** hereinafter.
- STC. 4.8.3. The successful bidder fails within the specifies time limit to:
- Acknowledge the LOA/Order
 - Furnish the required Security Deposit
 - Non-performance of the contract by the Contractor
 - If any registered vendor with Fixed EMD withdraws its bid prior to finalisation of the order and during the period of bid validity, the Fixed EMD as deposited by the vendor shall be liable to be forfeited.

STC 5 VALIDITY OF OFFER (प्रस्ताव की वैधता)

- STC 5.1. Offer should remain valid for a period of as per terms of specific NIT Terms & Requirements (90/120/180 days) from the due date of the tender.

STC 6 VENDOR'S CONFIRMATION W.R.T. LIMITED TENDER ENQUIRY

- STC 6.1. In case of Limited tender any bidder is not interested to quote, Vendor's confirmation of having received the tender but not willing to quote / regretting to quote, must be forwarded for GRSE reference & records. This should be treated as a requirement for the Vendor's name to be retained in GRSE's select list. In case where a particular Vendor has not responded to tender enquiry for more than 3 times, its name will be liable for de-registration.

STC 7 SECURITY DEPOSIT (INTEREST FREE) प्रतिभूति (ब्याज रहित)



- STC 7.1. Successful bidder will deposit an amount equivalent to the declared per cent of the total contract value as interest free Security Deposit (SD) in the form of Pay Order/D. D/Bank Guarantee (with validity of sixty days beyond contract period as per GRSE format) on any schedule bank other than Co-operative bank payable at Kolkata, duly crossed favouring Garden Reach Shipbuilders & Engineers Limited., within 15 days from the date of site clearance/receipt of LOA or PO/as specified in the NIT. In case of non-submission of SD as per schedule, penal interest will be charged for delayed period of submission of SD beyond 15 days at the prevailing SBI cash credit rate on the amount of SD to be submitted.
- STC 7.2. If S.D is submitted in the form of B.G then same is to be forwarded directly to Gen. Mgr. (Finance) in Banker's sealed envelope failing which same will not be accepted. Details of B. G. should also be confirmed to Ordering Department, GRSE.
- STC 7.3. S.D. amount would be refunded / returned after successful execution of the job and certification of Material Reconciliation Statement by Internal Audit, if applicable. Vendor is to apply for release of their SD along with Job Completion Certificate which has to be certified by PL/ Engineer-in-charge /authorized representative of concerned department through GRSE Ordering Dept. In the event of failure to execute the order satisfactorily or default by the contractor/ sub-contractor, the security deposit will be forfeited.

STC 8 WORK DONE CERTIFICATE (W.D.C.) (किए हुए काम का प्रमाणपत्र)

- STC 8.1. Firm will put up Work Done for certification to site engineer /PL /or as specified in the NIT, along with clear inspection report signed by Quality Assurance Authority. W.D.C. is to include whether work has been completed as per delivery schedule or the delay in days/weeks occurred in completion of work.

STC 9 BILL SUBMISSION (बिल प्रस्तुति)

- STC 9.1. On obtaining WDC, bills are to be raised on monthly/quarterly/half-yearly/annually (as specified in NIT) progressive basis in accordance with the Checklist as per GRSE format. Bills are to be submitted at the Bill Receiving Counters located at the respective unit of Company. Bill is to be submitted (in 03 copies) in sealed envelope super-scribing on the envelope the Purchase Order No., Vendor code, Bill / Invoice No., Name of person /employee to whom bill is addressed, for processing. For this Service Name of the person to be mentioned on sealed envelope will be concerned Project Leader of the Ship/Bill certifying officer.
- STC 9.2. Transaction fee of Rs. 500.00 for first return & Rs. 1000.00 for subsequent return of bill with inappropriate documents will be charged.

STC 10 COMPLIANCE OF ESI & PF (ईएसआई और पीएफ का अनुपालन)

- STC 10.1. Compliance of ESI & PF of the engaged workman is the responsibility of the contractor.
- STC 10.2. For execution of job inside GRSE premises, vendor has to obtain clearance from HR Dept. regarding statutory compliance of minimum wages, PF, ESI, etc. of their engaged workmen for release of payment.

STC 11 POLICE VERIFICATION FOR CONTRACT LABOUR WORKMEN (ठेका श्रमिकों का पुलिस सत्यापन)

- STC 11.1. Police Verification certificates of character antecedents in respect of all employees of Contractors/Sub-contractors for operating inside GRSE Ltd. are required to be submitted to Security Dept./GRSE Ltd. before processing of Gate Passes.
- STC 11.2. A certificate from the contractor's labour, clearly endorsing that characters of all his labourers have been duly verified and found to be satisfactory be submitted to GRSE at the time of making Gate Pass.
- STC 11.3. Photo Identity Card /Gate Pass as required by GRSE will be arranged by the contractor for his employees at his own cost.

STC 12 GST REGISTRATION (जी एस टी पंजीकरण)



STC 12.1. The vendor will have to submit copy of GST registration certificate (Part A & Part B) along with the Technical bid. Any bidder without having GST Registration Certificate will not be considered for Ordering.

STC 13 GUARANTEE PERIOD (गारंटी अवधि)

STC 13.1. Guarantee / Warranty is applicable for a Period of as stipulated in NIT Terms & Requirements from the date of completion of work.

STC 13.2. Workmanship will be guaranteed for satisfactory performance for a period as stated in NIT. Any faulty work carried out by the sub-contractor is to be rectified by them within the time stipulated by the GRSE. In case of failure of sub- contractor to meet the ship's programme, outstanding deficiencies shall be rectified by GRSE and all costs of such work shall have to be borne by the sub-contractor).

STC 13.3. During guarantee/ warranty period if any equipment or any component thereof supplied by the contractor, suffers due to defective material and/ or due to improper design and/ or due to defective drawing or due to faulty workmanship, the contractor will assume full responsibility of rectification of such defective equipment or component thereof including all direct expenses relating to removal and re-positioning of the replacement/ repaired equipment or component thereof and subsequent test & trial, incurred thereon without any financial implication to GRSE.

STC 14 PRICE (मूल्य)

STC 14.1. For Tender in NIC Portal (एन आई सी पोर्टल टेंडर हेतु)

STC. 14.1.1. Price bid need to be filled up (excluding GST) in html format only through e-portal. No other attachment regarding price will be allowed, if so, then offer will be rejected. For break-up of prices, GRSE may attach excel sheet with the html format price bid and the bidder has to fill up their prices in excel sheet and also in html format as per instruction in NIT.

STC 14.2. For Tender in GeM Portal (जे ई एम पोर्टल टेंडर हेतु)

STC. 14.2.1. Price bid needs to be filled up (with or without GST as specified in NIT) only through GeM portal for the total job.

STC. 14.2.2. The Bidder may have to upload the breakup of their quoted price in line with BOQ, as specified in NIT, along with their price offer in GeM portal.

STC. 14.2.3. The price should remain firm & fixed till satisfactory execution of the entire contract as per NIT. GST percentage has to be indicated in the offer. GST registration certificate for the service being tendered is to be enclosed with the techno-commercial bid. GST registration number is to be quoted in all bills.

STC 15 QUANTITY VARIATION (मात्रा भेद)

STC 15.1. Quantity as specified in the NIT/SOTR/Price Bid is tentative and it may vary according to the actual requirement of the job. The selected bidder has to execute the required quantity at the same rate, terms & conditions up to variation (+/-25%) or as specified in the NIT in addition to the initial tendered quantity. Necessary amendment of Purchase Orders will be issued accordingly.

STC 16 UNREASONABLE QUOTES अतर्कसंगत भा

STC 16.1. For Job Contract (कार्य संविदा हेतु)

STC. 16.1.1. In case the price of L-1 Bidder is found to quote unreasonably low and/or express desires to withdraw from the tender then such bid will be cancelled and EMD will be forfeited and punitive action will be taken in line with the provision as per GRSE Vendor Policy.

STC. 16.1.2. However, in case the L1 Bidder agrees to take-up the job with such unreasonable low quote, lower by 30% or more than estimate and also if the difference in price between L1 & L2 is 30% or more, then the quoted price to be analysed w.r.t tender requirement and if the L1



bidder fails to justify their quoted rate, the obtained L1 quote will be rejected and punitive action will be taken in line with the provision as per GRSE Vendor Policy.

- STC. 16.1.3. If the justification is acceptable to GRSE, then the bidder has to submit Bank Guarantee of 10% of the total Contract value (inclusive of GST) in addition to the Security Deposit (SD) and Performance Bank Guarantee (PBG) for execution of the job till satisfactory completion of entire contract. There shall be no exemption / relaxation for the Guarantee against unreasonable quote. In case of breach of contract GRSE shall reserve the right to invoke the BG and may impose tender holiday for a period as per GRSE Vendor policy.

STC 16.2. For Manpower Contract (श्रमशक्ति संविदा हेतु)

- STC. 16.2.1. The quoted price of the L1 bidder should comply with the prevailing Minimum Wages Act & Other Statutory requirements i.e PF, ESI etc.
- STC. 16.2.2. In case the quoted price of the L1 bidder is found unreasonably low i.e does not comply with the Minimum Wages Act & Other Statutory requirements and the L1 bidder fails to justify their quoted rate then the obtained L1 quote will be rejected and punitive action will be taken in line with the provision as per GRSE Vendor Policy.

STC 17 JOINT VENTURE (संयुक्त ऊधम)

STC 17.1. The bids submitted by a joint-venture company of two or more firms/persons/entities as partners/promoters shall comply with the following requirements:

- STC. 17.1.1. The Joint Venture Agreement must be a registered document under the Indian Registration Act and must be an independent and registered entity under the Companies Act/Indian Partnership Act, having its own trade name and having separate CIN, PAN, GST and other Statutory Licenses/Registrations independent of its promoters/partners.
- STC. 17.1.2. All partners/promoters of the joint venture shall be liable jointly and severally for the execution/performance of the project/contract and for all sorts of contractual obligations, responsibilities and liabilities and consequences arising out of breach of terms and conditions of contract.
- STC. 17.1.3. A Certified/True copy of the Joint Venture Agreement shall have to be submitted with the bid along with the resolution of Board of Directors (in case of a company) or a Power of Attorney to be executed by all the Partners (in case of Partnership Firm) of JV entity authorizing such person who will sign on behalf of JV entity.
- STC. 17.1.4. Submission of EMD/SDs/Performance Guarantee etc., to be made by the Joint Venture Company/Firm and similarly all payments would also be remitted to/in favour of the JV entity.
- STC. 17.1.5. In order for a joint venture to qualify/meet the minimum criteria as may be specified in the Tender, the experience and financial capability of each of its promoters/ partners would be considered jointly to judge the experience and/or the financial capability of the JV entity as an independent entity. That is to say that the individual experience/qualification of each partner/promoter of the JV would be considered together for ascertaining the experience/qualification criteria of the JV. However, if any specific criteria/qualification is mentioned in the Tender that has to be met by each of the partners, then in such case each of the JV partner/promoters have to meet the same.
- STC. 17.1.6. Neither the JV entity nor any of its partners/promoters should have been blacklisted, banned or debarred from issuing any Tender or suffering Tender Holiday from participating in any Tender process of Government of India or any of its Agencies or by any State Government or by an PSU (both Central & State included) or by any Court/Tribunal. If so, then the bid is liable to be rejected.
- STC. 17.1.7. If selected, PO would be issued in favour of the JV.

STC 18 CONSORTIUM (अल्पकालीन संघटन)

STC 18.1. The bids submitted by a Consortium of two or more firms as partners shall comply with the following requirements:



- STC. 18.1.1. There must be a written Agreement for formation of the Consortium amongst its members which should inter alia include the role of each member, the ratio of investment and the ratio of profit/loss sharing. The terms of the Agreement cannot be modified post submission of the bid and during execution of Contract, if awarded, without the express consent of GRSE. The Consortium Agreement must record that as to which member would act as the Lead Member in the Contract/Tender. This authorization shall be evidenced by submitting with the bid a Power of Attorney authorizing such member to act on its behalf as Lead Member, signed by legally authorized signatories of all other partners/members.
- STC. 18.1.2. Each partner firm/company of a Consortium must legally authorize its representative who will represent the partner firm/company to sign and execute the Consortium Agreement and all other necessary papers/documents required for the formation of Consortium and all other purpose relating to activities of Consortium.
- STC. 18.1.3. The leader shall be authorized to incur liabilities and to receive instruction for and on behalf of any and all partners/members of the consortium and the entire execution of the contract and all other related documents shall be done under the supervision and involvement of the lead member.
- STC. 18.1.4. All partners of the consortium shall be liable jointly and severally for the execution of the project or contract without any limitation of liability. Any default or lapse on the part of any of the members of the Consortium regarding performance of the contract will be treated as default on the part of the Consortium as a whole and the Lead Member alone will be responsible for all consequential losses and damages that may be sustained by GRSE for such default or lapse on the part of a member.
- STC. 18.1.5. A Certified True copy of the Consortium contract/agreement entered into by and between the consortium partners and a certified True copy of the Power of Attorney, referred above, must be submitted with the bid and failure to submit any of such documents will make the bid of the Consortium liable to be rejected.
- STC. 18.1.6. If Contract is awarded to the Consortium, an Agreement would be executed by and between GRSE and all the Consortium members wherein, inter alia, the role of each member and the mode of payments to be specifically defined and/or mentioned. However, all the consortium members shall remain, jointly and severally, responsible for execution and completion of the Contract and also to make good for all losses and damages if any sustained or to be sustained by GRSE in the subject contract due to default and/or negligence of the Consortium as a whole or of any of its members. Any statement or clause seeking to limit the liability of each member of the Consortium, such statement or clause to be treated as incompatible with the principle of joint and several liability and the bid of the Consortium will be liable to be rejected as not in compliance of tender specifications, without further evaluation.
- STC. 18.1.7. In order to qualify/meet the qualification criteria, each of its partners/members or combination of partners/members must meet the minimum criteria set for the individual bidder. Failure to comply with this requirement will result in rejection of the Consortium's bid. The data/figures of each of the partners/members of the Consortium shall be added together in proportion to their participation in the Consortium, to determine the bidder's capacity as a whole to comply with the minimum criteria.
- STC. 18.1.8. The percentage of partnership of the lead partner shall be highest among all the Consortium partners. Bid has to be submitted by the Lead Partner in its name however it should be clearly indicated that the lead partner is submitting such bid on behalf of a Consortium of which it is the Lead Partner.
- STC. 18.1.9. The lead partner shall be responsible for payment of Bid Security/EMD as well as the Security Deposit & Performance Guarantee. However, the same has to be submitted by MSME/NSIC firms also if such firm acts as a Lead partner.
- STC. 18.1.10. All Payments to be made to the Lead Member pursuant to satisfactory execution of the job as specified in the Contract irrespective of the performance by all the members. Payments



made to Lead partner of the Consortium would be construed as valid payment. Further the Consortium members agree not to entangle GRSE in any internal dispute between the Consortium members regarding payment/non-payment or any other issue and accordingly waives their rights, if any in this regard.

- STC. 18.1.11. None of the consortium partners/members should have been blacklisted, banned or debarred or issued any Tender holiday from participating in Government Contracts by either the Government of India or any of its Agencies or by any State Government or by an PSU (both Central & State included) or by the Courts/Tribunals. If so, then the bid is liable to be rejected.

Note: The Consortium Agreement & the PoA is to be submitted by the Consortium's Lead partner along with the Bid for examination by GRSE. If the Consortium Agreement or the PoA does not meet the criteria as specified in the clause then such bid would be liable to be rejected.

STC 19 MAINTENANCE OF MACHINES (यंत्रों का अनुरक्षण)

- STC 19.1. The maintenance of machines brought in by contractors are to be undertaken as per OEM recommendations. Certificate to this effect is to be rendered by the contractor.

STC 20 SUB-CONTRACTING OF SUB-CONTRACTED JOB (उप संविदा कार्य का उप संविदा)

- STC 20.1. Sub-Contracting of the Sub-Contracted job is usually discouraged. When a contract is being finalised with a Vendor/ Contractor for execution of a particular job, the Contractor shall not sub-contract the job / a part of the job.

- STC 20.2. However, in case of requirement, the job in part or full could be sub-contracted with an approval from GRSE and copy of the same has to be forwarded to Ordering Dept. & HR Dept. for their information.

- STC 20.3. For sub-contracting of the sub-contracted job, the Vendor/Contractor has to submit the details of the sub-contractor to whom the job will be loaded including their name, credentials, document of past performance etc. for approval of GRSE Engineer In-Charge/ In-charge of User Dept./Project Leader / Project Superintendent /Head of Units.

STC 21 EXCESS/WASTE/REJECTED MATERIALS (अतिरिक्त/बेकार/ अस्वीकृत सामग्री)

- STC 21.1. Removal of excess/waste/rejected materials etc. generated during execution of work should be arranged by the Contractor at their own cost immediately after completion of work each day and for non-removal of same by the Contractor, the expenditure incurred by GRSE (if any) in removing these materials will be recovered from the available dues of the Contractor.

STC 22 FIRE & SAFETY PRECAUTIONS (अग्नि एवं संरक्षा सावधानियाँ)

- STC 22.1. The Vendor/Contractor shall abide by the Safety regulations/rules of the GRSE as detailed in Fire & Safety Guidelines (please refer www.grse.in). The Vendor/Contractor should take all safety precautions and provide adequate supervision & control for their workmen in order to carry out the job safely. In case of any violation of safety precaution and non-usage of safety equipment, Contractor shall be liable for a penalty which is detailed in Fire and Safety Guidelines (please refer www.grse.in). Penalty amount depends on the type and frequency of violation mentioned in the safety guideline and the same will be deducted from the defaulter's bill.

STC 23 SAFETY GUIDELINE FOR MATERIAL HANDLING EQUIPMENT (सामग्री चालन उपकरण हेतु मार्गदर्शन)

- STC 23.1. The Vendor/Contractor shall abide by the Safety Guidelines /regulations of GRSE as detailed in NIT. The Vendor/Contractor should comply with all the Safety requirements like Statutory Examination and Certification of Crane & associated lifting tackles, Display of SWL, Competency requirement of Crane Operators, PUC etc. in order to carry out the job safely. In case of any violation GRSE will take appropriate action as per policy.

STC 24 MANDATORY USE OF ISI MARKED PPE BY CONTRACTOR EMPLOYEES (संविदा कर्मचारी द्वारा आई एस आई निशान पी पी ई व्यवहार की अनिवार्यता)



STC 24.1. The Contractor shall ensure the use of ISI marked PPE by their engaged Employees. An indicative list of ISI marked Personal Protective Equipment, is appended below for mandatory compliance by the vendors without any deviation:

STC 24.2. LIST OF PPES (पी पी ई की सूची)

SI. No.	Description	Name of PPE	Applicable area of Protection	Standard
(i)	Head Protection	Safety Helmet	In the shop floor / on board ship / working at height / under the suspended load or any other place where there is any possibility of head injury.	IS: 2925 or EN 397.
(ii)	Foot Protection	Safety Shoes	(a) Mandatorily wear safety shoe while working in shop floor / on board ship/ Stores/ Dock floor or any other place where there is possibility of foot injury. (b) Mandatorily wear closed footwear while entering the shipyard. (c) Wear Rubber Gumboot while working in water logged condition for removing of water from ship's tank, compartment, Dock Galley etc., cleaning of Dock floor / acid pickling area/ canteen cooking and washing areas etc.	(a) IS 15298 / EN ISO 20345 (b) Non ISI (c) IS: 12254
(iii)	Eye Protection	Safety Goggles	When engaged for welding / gas cutting / grinding / chipping / painting / chemical handling or any other activity where there is a possibility for eye injury due to penetration of flying particles / ultra violet radiation / splashing of chemical etc.	ANSI Z87.1 or EN166.
(iv)	Ear Protection	Ear Plug	In high noise area (>90 db).	IS: 9167/ EN 352
(v)	Hand Protection	Hand Gloves	(a) Leather Hand Gloves – During material handling / welding / gas cutting or any other activity where there is possibility of hand injury due to contact with sharp edges, hot spatter from welding or gas cutting processes. (b) Electrical Rubber Hand Gloves – While executing any electrical maintenance jobs. (c) Acid / Alkali Proof Rubber Hand gloves – During handling of acid, skin irritants chemical & solvent etc.	(a) IS:6994/EN 407 for heat applications (gas cutting / welding) / EN 420 for general requirement / EN 388 for mechanical hazard (b) IS 4770 for electrical work (c) EN 420 for general requirement



Sl. No.	Description	Name of PPE	Applicable area of Protection	Standard
				(d) EN 388 for mechanical hazard
(vi)	Respiratory Protection	Welding Fume Respirator, Paint Fume Respirator or, Dust mask	Dust Respirator – To be worn during grinding job, floor cleaning, dusting or any other activity where there is possibility of producing dust. (b) Welding Fume Respirator – To be worn during welding, gas cutting, brazing job etc. (c) Chemical Respirator – To be worn during painting, mixing of paint with solvents & FRP activities handling of acid, skin irritants, chemical & solvents etc.	(a) IS: 9473 / EN: 149 (b) IS: 9473 / EN: 149 (c) IS: 15323 (Selection to be made according to the particular chemical hazard)
(vii)	Fall Protection	Double lanyard Safety Belt & harness, automatic fall arrestor	To be worn while working in height: (a) Double Lanyard Full Body Harness – During working at height such as on scaffolding structure / suspended working platform / ship's mast / fragile roof / inclined surface on the roof top or at any other height where there is a possibility of person to fall and get injured. (b) Automatic fall arrestor (in addition to full body harness) – To be worn during carrying out job in the vertical ascending / descending on the scaffolding structure, working on the suspended working platform and inclined surface on the roof top, horizontal movement at height.	(a) IS: 3521 (b) EN 361
(viii)	Electric Arc Flash Protection	Electric Arc rated flash suit jacket, pant, hood and gloves	To be worn during operation & maintenance of electrical installations inside the HT Switch Gear Rooms.	As per guideline of NFPA-70E
(ix)	Fire-Fighting protection	(a) Three Layer Fire Close Proximity Suit (b) Self-Contained Breathing Apparatus (SCBA) Set	Personnel engaged in Fire Fighting service should wear Fire Close Proximity Suit and use Self-Contained Breathing Apparatus (SCBA) Set during combating fire in a hazardous environment.	Fire Proximity Suit approved by EN-469:2005 + A1: 2006 + AC: 2006D and CE. Jacket & Trouser (EN-469) Hand Gloves (EN-659) Outer Head Protection Helmet (EN-



Sl. No.	Description	Name of PPE	Applicable area of Protection	Standard
				443/1997) and inner Protection EN 1391, Self-Contained Breathing Apparatus(SCBA) Set, as per approval of CE and EN-137 CLASS II standards and Approval of PESO
(x)	Face protection	Industrial safety face shields with plastic visor	When person engaged for grinding / chipping / buffering or any other activity where there is a possibility for face injury due to penetration of flying particles	IS 8521 Design of visor may be selected as per design of safety helmet
(xi)	Protective Clothing	Cotton boiler-suit	In the shop floor / on board ship / production floor and in any other areas of operation.	IS: 177- 1989 (Reaffirmed in 2003), Variety 3 standard
	Note: Cotton-boiler suits should bear name of the contractors' firm on the back-side of the boiler-suit in legible manner for easy identification.			

STC 24.3. Role of Contractors

- STC. 24.3.1. Shall ensure attendance of their workmen and other personnel deployed by them, in the scheduled safety-briefings, appropriate use of required PPEs and adoption of various safety measures in their respective workplaces.
- STC. 24.3.2. Shall provide adequate and appropriate PPEs conforming to IS / EN standards, as mentioned at Para 3 and 4 of the Policy, at their own cost and ensure that their workmen mandatorily use those PPEs as specified in this Policy vide Sl. No. 3 or as advised by Safety Department from time to time, according to the job requirement.
- STC. 24.3.3. Shall ensure submission of PPE Issue Matrix Register (as per Annexure – II) to the user department before commencement of work. Such Register should comprise of the name of the contractor, P.O No., name of the workmen being deployed, allotment of PPEs and signature of contractors' workmen substantiating allotment of PPEs to them as per the IS parameter laid down at Para 3 and 4 above.
- STC. 24.3.4. Every contractor should ensure that their workmen have undergone safety training programme, as per their nature of work, prior to commencement of work. Contractor has to submit a report to the engaging / user department after completion of safety training programme for obtaining permission to commence work under the particular P.O. A copy of that report has to be forwarded to Safety Department for information and record.
- STC. 24.3.5. In the event of any accident, the concerned contractor / their site In-charges / supervisors must immediately inform the respective dealing officer of user department regarding occurrence of such accident, who in turn will inform Works Manager of the respective unit and Officer from Safety Department for initiation of further necessary action.
- STC. 24.3.6. Ensure that no workman or other personnel deployed by them should loiter or work in shop floor, onboard ship or in the yard without wearing basic PPEs like helmet, safety shoes etc.



STC 24.4. Role of contractors' workmen

- STC. 24.4.1. Adhere to all necessary safety-guidelines at their work-sites and use appropriate PPEs.
- STC. 24.4.2. Inform their supervisors / site In-charges in the event of loss or damage of their safety gears / PPEs so that the same can be replaced immediately by the concerned contractor and should not be a reason for non-compliance.
- STC. 24.4.3. To communicate proper use of PPEs to their co-workers in the event there is any non-compliance.

STC 24.5. PENAL PROVISIONS FOR NON-COMPLIANCE

S/N	Type of violation	Penalty (INR)			
		1 st Instance	2 nd Instance	3 rd Instance	4 th Instance
(i)	Not having / not using PPEs properly	INR 10,000/-	INR 15,000/-	INR 20,000/-	Discontinued / debarred from participating in future tender upto 06 months / 02 consecutive tenders.
(ii)	Use of defective / non IS PPEs	INR 5,000/-	INR 10,000/-	INR 15,000/-	

STC 24.6. DISCONTINUATION OF CONTRACT

- STC. 24.6.1. In the case of repeated violation of safety guidelines, i.e, for more than 04 (four) instances during any Financial Year, GRSE shall have the sole discretion to terminate all / such affected contracts of the concerned non-complying contractor. GRSE may also impose Tender Holiday up to maximum period of 03 years in the event of 05 instances of violation. Tender Holiday will be issued on recommendation of existing Standing Committee and approval of Competent Authority.

STC 25 ENVIRONMENT MANAGEMENT AND OCCUPATIONAL HEALTH & SAFETY (पर्यावरण प्रबंधन एवं व्यावसायिक स्वास्थ्य सुरक्षा)

- STC 25.1. The vendor shall ensure compliance of Environment Management System (ISO14001:2014), Occupational Health & Safety (ISO 45001:2018) & Energy Management System (ISO 50001:2011) while carrying out their activity in the yard.

STC 26 ENERGY CONSERVATION (ऊर्जा संरक्षण)

- STC 26.1. GRSE will provide power supply at free of cost for execution of job. The vendor should ensure that the power during execution of job shall be used in a very economical way to save energy as per Energy Management System of ISO 50001: 2011.

STC 27 GUARANTEE FOR RAW MATERIAL (अनिर्मित सामग्री की गारंटी)

- STC 27.1. This Clause will be applicable for Collection of Raw materials /Free Issue materials from GRSE for the jobs which are to be executed outside GRSE premises.
 - STC. 27.1.1. Raw materials will be required to collect from GRSE against submission of Bank Guarantee as per GRSE format for the equivalent value of material as specified in NIT/Purchase Order. Transportation of materials from GRSE to Sub-contractor's premises and transportation of finished materials from Sub-contractor's premises up to GRSE is the responsibility of the contractor or as specified in NIT.
 - STC. 27.1.2. Indemnity Bond affixing the Common Seal from the registered sub-contractors may be accepted in lieu of Bank Guarantee but it should be backed by Insurance Coverage with GRSE as the beneficiary on case to case basis. If the contractor is unable to take coverage, GRSE will cover such risk and cost of premium will be borne by the contractor/recovered from their dues.
 - STC. 27.1.3. Indemnity Bond has to be submitted as per GRSE Format on the non-judicial Stamp paper of value Rs. 100/- and to be Notarized if Common Seal is not applicable.



- STC. 27.1.4. During collection of material, the Transporter of the Sub-Contractor has to submit L-R copy, failing which materials will not be issued to the Sub-Contractor.
- STC. 27.1.5. For the jobs which are to be executed inside GRSE premises, submission of Bank Guarantee or Indemnity Bond for Collection Raw materials is not required.

STC 28 MATERIAL RECONCILIATION STATEMENT (MRS) (सामग्री मिलान विवरण)

- STC 28.1. Firms are to furnish the material reconciliation statement (running MRS) to GRSE, for items supplied by GRSE for execution of a job at vendor's premises. Furnishing of MRS to be done immediately on delivery of the Finished item/Block but not later than 30 days of delivery of the finished item showing details of raw materials received, material actually consumed, excess material returned, wastage etc. This statement should be submitted with documentary evidence of material issued/returned/wastage duly accepted by competent authority of GRSE and as per the GRSE format and filled up check list for MRS. Permissible variation in MRS is 1.5% of design weight of structure. MRS certification is to be completed by GRSE within 60 days of receipt of the same from vendors.
- STC 28.2. Quantity of stiffeners used in transportation are to be mentioned in delivery challan clearly indicating whether the stiffeners are: -
- STC. 28.2.1. Temporary stiffeners supplied by vendor.
- STC. 28.2.2. Sections of ABS quality supplied by GRSE.
- STC 28.3. While submitting MRS of Finished item/Block, copies of certified MRS of all previous Finished items/Blocks are to be enclosed. This will be called the final MRS.

STC 29 INSURANCE (बीमा)

- STC 29.1. In case the sub-contracted job has to be executed at contractor's premises, the Insurance has to be taken by the contractor with appropriate value coverage for the underlying risks (the beneficiary would be GRSE by endorsement) e.g. Loss due to following:
- STC. 29.1.1. Fire as per AIFT including EQ, STFI at Contractors premises.
- STC. 29.1.2. Burglary including theft during Storage at Contractors premises.
- STC. 29.1.3. Marine transit to and fro as per ITC(A) including SRCC (on the basis of agreed valuation between GRSE & contractors).
- STC. 29.1.4. Loading & unloading including TP liability at all fabricator's premises.
- STC. 29.1.5. Loss due to infidelity of contractors whilst in storage.
- STC. 29.1.6. Spoilage of material by contractors by any accidental reasons whatsoever.
- STC 29.2. If the contractor is unable to take coverage, GRSE will cover such risk and cost of premium will be borne by the contractor/recovered from their dues.
- STC 29.3. For the jobs which are to be executed inside GRSE premises, Insurance coverage will not be the responsibility of contractor.

STC 30 SITE-INCHARGE/ LOG BOOK/ HINDRANCE & OTHER RECORDS (कार्यस्थान प्रभार/कार्यपंजी/बाधा एवं अन्य रिकार्ड)

- STC 30.1. One fully responsible and Qualified Site-in-charge has to be posted at the site during progress of work.
- STC 30.2. Attendance Register, Wage Register etc. are to be maintained daily for the particular job on board and to be shown as and when required.
- STC 30.3. Details of technical personnel deployed for the job.
- STC 30.4. Monthly progress report.
- STC 30.5. Log book for re-work/ modification.



- STC 30.6. Details of materials brought by vendor along with copies of challan.
- STC 30.7. Proper record of hindrances is to be maintained by the sub-contractor for the purpose of timely removal of the hindrance and is to be put up for approval by Project Leader/Site Engineer on weekly basis. A copy of the same would have to be enclosed while submitting any request for waiver of liquidated damages.
- STC 30.8. Sufficient Supervisory Staff should be provided by the contractor during execution of work and in case of any accident/ damage to GRSE properties, full responsibility will be attributed to the contractor and loss incurred will be recovered from the contractor.

STC 31 WORKING HOURS (कार्य समय)

- STC 31.1. The Contractor's normal working hours shall be in between 8 AM-5:06 PM from Monday to Friday & from 8:00 AM to 1:00 PM on Saturday. 1st & 3rd Saturday is Non-Duty Saturday. Work may also be required to be carried out in shifts (A, B & G shifts) as per GRSE's requirement. Also, work may be required to be carried out on Sunday/Holiday or beyond schedule working hours as per requirement of GRSE and the Contractor will have to arrange for same as per NIT Terms.

STC 32 RISK PURCHASE (जोखिम खरीद)

- STC 32.1. In case the progress of work is not satisfactory and the contractor fails to maintain the schedule, GRSE reserves the right to get the work done by alternative source at the risk and cost of sub-contractor.
- STC 32.2. GRSE shall be at liberty to purchase/obtain the service from the alternative source as it deems fit, to make good such default and or in the event of the contract being terminated, the balance of the remaining service to be delivered there under. Any excess over the job price / service rates, paid and incurred by GRSE, as the case may be, over the contract price shall be recoverable from the firm. To make good the recoverable excess amount paid, GRSE shall be at liberty to invoke Bank Guarantee and/or with other available dues of the firm.

STC 33 INDIVIDUALITY OF THE CONTRACT (संविदा की वैयक्तिकता)

- STC 33.1. This Contract should be treated as an individual contract and should not be related with other orders with GRSE in respect of progress of work or payment.

STC 34 SECRECY OF INFORMATION (सूचना की गोपनीयता)

- STC 34.1. All documents and drawings of this project are of confidential in nature and should be used explicitly for the purpose for which they are provided. Drawings should not be copied and should be returned to GRSE on completion of work.
- STC 34.2. No information in respect of contracts/orders shall be released to the national or international media or any one not directly involved its execution without the express written approval of the Integrated Headquarters, MOD (NAVY). In the event of any breach of above provisions, the vendor would have to make good of any loss/ cost/ damage/ any other claim whatsoever preferred by anybody to GRSE in this respect.
- STC 34.3. Non-Disclosure Agreement (NDA) as specified in the NIT has to be submitted as per GRSE Format.

STC 35 REGISTRATION OF NEW VENDOR (नए बिक्रेता का पंजीकरण)

- STC 35.1. The contractor has to confirm if they are registered with GRSE and Indicate Vendor Code (5 digits) and Product Code group accordingly in their offer. If the contractor is not registered with GRSE, then documents required for provisional vendor registration has to be submitted to the Ordering Department. For Permanent Vendor Registration with GRSE, the contractor has to submit their application to GRSE Vendor Development Cell.

STC 36 CONTRACT WORKMAN WAGE PAYMENT (संविदा कामगार का मजदूरी भुगतान)



STC 36.1. Payment of wages to the contractor's employee/workmen should be made through individual bank account on monthly basis instead of cash payment. PF-UAN activation of all the contractor's employee/workmen is mandatory.

STC 37 INSPECTION (निरीक्षण)

STC 37.1. Quality assurance authority: As per NIT/SOTR.

STC 37.2. Inspection to be carried out stage wise by Quality Assurance Authority. On completion of work for any stage, vendor has to submit Inspection Offer to GRSE (Inspection Agency) for stage inspection. GRSE (Inspection Agency) shall co-ordinate with the Outside Inspection Authorities (as applicable) for carrying out inspection of completed job.

STC 37.3. GRSE reserve the right to inspect all operations to be carried out by the contractor. Free access to the work site at all the time shall be ensured by contractor. The presence or absence of GRSE representative does not relieve contractor of the responsibility for quality control. The contractor shall provide all assistance for carrying out inspection of completed work.

STC 37.4. Repeat inspection for any particular job is to be discouraged as far as possible. Hence the vendor should complete the job in all respect prior to submission of Inspection Offer to avoid reoffering. In case of repeat inspection happens for more than two occasions then the additional cost implication incurred by GRSE will be deducted from the bills of the vendor at actual. Number of occasions of repeat inspection for any particular job is to be indicated by GRSE in inspection note and same is to be incorporated in the work done certificate for deduction of additional cost implication for repeat inspection. Cost of deduction shall be calculated by Executing Dept., GRSE with the help of Finance Dept., GRSE.

STC 38 CORRECTION OF ERRORS (त्रुटि सुधार)

STC 38.1. Bids determined to be responsive will be checked by GRSE for any arithmetic error. Errors will be corrected by GRSE as follows:

STC 38.2. For Manual Tendering: -

STC. 38.2.1. Where there is a discrepancy between the rates in figures and in words, the rates in words will govern.

STC. 38.2.2. Where there is a discrepancy between the unit rate and the line item total resulting from multiplying the unit rate by the quantity, the unit rate as quoted will govern.

STC 38.3. For Tendering through NIC Portal: -

STC. 38.3.1. Where there is a discrepancy between the rates in html format and the attachment to price bid (if applicable), the rates in attachment to price bid will govern. In attachment to Price bid; if any discrepancy found between the unit rate and the line item total resulting from multiplying the unit rate by the quantity, the unit rate as quoted will be considered.

STC 38.4. For Tendering through GeM Portal: -

STC. 38.4.1. Where there is a discrepancy between the total price quoted in GeM Portal and the attachment (i.e break up of quoted price in line with BOQ) to price offer, the total price quoted in GeM portal will govern. In attachment to the Price offer, if any discrepancy found between the unit rate and the line item total resulting from multiplying the unit rate by the quantity, the unit rate as quoted will be considered.

STC 39 FORCE MAJEURE (अप्रत्याशित घटना) :

STC 39.1. In the event of contractor being unable to fulfil the obligation under the agreement owing to force majeure, such as War, Fire, Earthquake, Flood, Strike/ Lockout at GRSE premises where the contractor is working, the party affected shall not be held responsible for any failure or non-performance of the duties and obligations under the agreement, provided that all responsible efforts have been made to overcome the consequences of such failure, or non-performance. The time for



performances of the contractual obligation shall then be extended by period not more than the duration of such events.

STC 39.2. In the event of Force Majeure condition existing at contractor's site in GRSE Premises or CPT areas for GRSE work, GRSE is to be intimated with details of such happenings and cessations thereof, within 3 days. Force Majeure is to be limited to contractor's site in GRSE/CPT premises for GRSE's work only. Lock out/ Closure of contractor's factory premises or office or any other place outside GRSE/CPT/GRSE nominated place as indicated above cannot be considered as a Force Majeure condition under this contract.

STC 40 TERMINATION OF CONTRACT (अनुबंध की समाप्ती)

STC 40.1. In the event of non-performance or non-engagement of manpower for the execution of the job within the notice period, GRSE reserves the right to cancel the order in part or in full, and no compensation whatsoever will be entertained.

STC 41 DAMAGE OF MATERIALS / EQUIPMENTS (सामग्री/उपकरण की छती)

STC 41.1. The contractor will ensure that no damage is caused to the materials, equipment or any other property of GRSE due to negligence and / or any reason whatsoever by the contractor's personnel. The cost of such damage will be suitably recovered from contractor's bills.

STC 42 OFFICE & STORAGE SPACE (कार्यालय एवं भंडारण स्थान)

STC 42.1. The contractor will have to arrange their office & storage required for execution of job, for cumulative order value of Rs.75 lakhs and above, of their own. However, space for placing up to one container will be provided free of cost by GRSE. Container will have to be removed by the contractor within 03 months from the date of final settlement with GRSE. In case of non-removal of container within specified period penalty as deemed fit will be imposed for the occupied area of GRSE.

STC 43 ARBITRATION (मध्यस्थता)

STC 43.1. If at any time, before during or after the contract period, any unsettled claim, question, dispute or difference arises between the parties, upon or in relation to or in connection with or in any way touching or concerning this order, the same shall be settled/adjudicated through Arbitration to be conducted by a Sole Arbitrator, to be appointed by the parties on mutual consent, in accordance with the provisions of the Arbitration and Conciliation Act, 1996.

STC 43.2. In the event the parties fail to mutually appoint a Sole Arbitrator within 30 days from the receipt of a request by one party from the other, then either of the parties may approach the Hon'ble High Court at Calcutta under the provisions of the Arbitration and Conciliation Act, 1996 for appointment of a Sole Arbitrator by the Hon'ble Court.

STC 43.3. Such arbitration shall, in all respects, be conducted in accordance with the provisions of the Arbitration and Conciliation Act, 1996 and the rules framed there under or any statutory modification or re-enactment thereof for the time being in force.

STC 43.4. The Award of the Sole Arbitrator shall be final, conclusive and binding upon the Parties.

STC 43.5. In the event of the death or resignation or incapacity or whatsoever of the said Sole Arbitrator if appointed by the parties mutually the said parties may again appoint a suitable Substitute Arbitrator in place of the erstwhile Sole Arbitrator to continue with the proceedings. In the event of appointment of the Sole Arbitrator by the Hon'ble High court at Calcutta on death or resignation or incapacity or whatsoever of the said Sole Arbitrator, either of the parties in this behalf, may make an application to the Hon'ble High court at Calcutta for appointment of a Substitute Arbitrator and the Hon'ble Court may pass such orders as it deems fit and proper.

STC 43.6. Also, in the event an Arbitration award is set aside by a competent court the parties may appoint a Sole Arbitrator mutually or on failing to appoint a Sole Arbitrator mutually within the statutory period then either of the parties may file an application before the Hon'ble High Court at Calcutta under the provisions of the Arbitration and Conciliation Act, 1996 for appointment of a Sole Arbitrator by the Hon'ble Court in accordance with the provisions of the Arbitration & Conciliation Act.



STC 43.7. The cost of the arbitration, fees of the arbitrator, remuneration of the stenographer and clerk, stamp paper etc. shall be shared equally by the parties, unless otherwise directed by the Sole Arbitrator. The venue of arbitration shall be at Kolkata and unless otherwise decided by the parties or by the Sole Arbitrator himself, the venue shall be the premises of Garden Reach Shipbuilders & Engineers Ltd. located at 43/46, Garden Reach Road, Kolkata 700 024.

STC 43.8. The language of the proceeding shall be in English.

STC 44 JURISDICTION (न्याय अधिकार)

STC 44.1. Litigation, if any, pertaining to this contract will come under the jurisdiction of High Court at Kolkata.

STC 44.2. All contracts shall be deemed to have been wholly made in Kolkata and all claims there under are payable in Kolkata City and it is the distinct condition of the order that no suit or action for the purpose of enforcing any claim in respect of the order shall be instituted in any Court other than that situated in Kolkata City, West Bengal State, India.

STC 44.3. The Firm is warranted that all service rendered by them shall conform to applicable city, states & central laws, ordinances and regulations and the said Firm shall indemnify / defend / relieve GRSE harmless, from / of against loss, cost of damage, by reason or any actual or alleged violation thereof.

STC 44.4. GRSE shall not be liable under the workmen's compensation Act of 1923; in case any employee or workmen receives injury while actually serving his employer in connection with the latter's work inside the compound of GRSE Ltd.

STC 44.5. All existing applicable Laws such as ESI, PF, SERVICE, CONTRACT LABOUR, CHILD LABOUR etc. as applicable, shall be binding for the contract.

STC 45 PREVALANCE OF NIT/STAC & CLARIFICATION

STC 45.1. For any discrepancy between NIT (Notice Inviting Tender) and STAC, NIT statement may be taken as final.

STC 45.2. Clarification required, if any, regarding Tender Document, should be got resolved by contacting competent authority of GRSE prior to submission of bid.



**ANNEXURE – 3: EXECUTED RELEVANT JOBS for TECHNICAL ELIGIBILITY
DURING LAST 03 YEARS
(To be submitted in Letterhead of bidder)**

1. **Name of the Bidder:**

2. **Job Description:**

3. **Tender Reference:**

(A) Details of Executed relevant jobs:

Sl. No	Description of Executed relevant jobs	Order No. & Date <i>(Supporting soft or, hard copy to be submitted)</i>	Start & Completion date as per Order	Actual start date	Actual Completion Date	Order placed by	Value of Purchase order & length of Plumbing work completed	Work completion certificate Ref. No. & date <i>(Supporting soft or, hard copy to be submitted)</i>

Note: Please add additional pages if required

(Signature of Authorized Representative)

Date:

Name:

Designation:



ANNEXURE – 4: FORMAT for FINANCIAL ELIGIBILITY
(To be submitted in Letterhead of bidder)

1. **Name of the Bidder:**

2. **Job Description:**

3. **Tender Reference:**

A. Financial Data for evaluating Financial Eligibility

SL. No.	Financial Years	Turn Over (Rs.)
1	2021-22	
2	2020-21	
3	2019-20	

(Signature of Authorized Representative)

Date:

Name:

Designation:

Note: Financial Statements to be attached



**ANNEXURE-5: FORMAT OF SELF-CERTIFICATION FOR DECLARATION REGARDING BLACKLISTING/
TENDER HOLIDAY**

(To be submitted in Letterhead of bidder)

1. Name of the Bidder with Address:

Date:

2. Job Description:

3. Tender Reference:

Sub: SELF-CERTIFICATION

I / We, Proprietor/ Partner(s)/ Director(s) of M/s. ----- hereby declare that our firm/company namely M/s.-----have neither been blacklisted nor have received any tender holiday by any PSUs/Central & State Govt. Organizations or any other Government / Quasi Government Organizations during last 03 (three) years ending on -----(date) from taking part in Government tenders.

Or

I / We Proprietor/ Partner(s)/ Director(s) of M/s. ----- hereby declare that our firm/company namely M/s.-----has received tender holiday from M/s-----
----- (name of PSUs/Central & State Govt. Organizations or any other Government / Quasi Government Organizations) from taking part in Government tenders for a period of ----- months w.e.f.-----
to -----(date). The period is over on -----(date) and now our firm/company is entitled to take part in Government tenders. (relevant withdrawal/revocation document is attached).

In case the above information is found inappropriate / false, I/We are fully aware that the offer submitted by our firm / contract awarded to our firm/company namely M/s ----- will be rejected/cancelled by M/s GRSE, and EMD/SD shall be forfeited and appropriate action will be taken in accordance with the vendor policy of GRSE.

(Signature of Authorized Representative with official seal)

Date:

Name:

Designation:

NB: PLEASE ENCLOSE COPY OF RELEVANT DOCUMENTS

*Strike out / omit whichever is not applicable



ANNEXURE-6: FORMAT FOR DISCLOSURE BY CONTRACTOR OF EXISTING WORK
(To be submitted in Letterhead of bidder)

1. **Name of the Bidder:**
2. **Job Description:**
3. **Tender Reference:**
4. **Details of Existing relevant jobs:**

Sl. No.	Description of Existing relevant jobs	Order No., Date & Value (in INR) <i>(Supporting soft or, hard copy to be submitted)</i>	Start & Completion date as per Order	Actual start date	Order placed by	Scope of work for existing contract (To quantify)	Deployment of operatives for the existing contract (category wise)				
							USK	SSK	SK	HSK	Equipment

(Signature of Authorized Representative with official seal)

Date:

Name:

Designation:

Note: Please add additional pages if required.



**ANNEXURE-7: FORMAT FOR DISCLOSURE BY CONTRACTOR OF PROPOSED EXECUTION /
DEPLOYMENT PLAN OF THIS TENDERED JOB
(To be submitted in Letterhead of bidder)**

5. **Name of the Bidder:**
6. **Job Description:**
7. **Tender Reference:**
8. **Details of Existing relevant jobs:**

Sl. No.	Deployment of operatives per month for the Tendered job contract (category wise)				
	USK	SSK	SK	HSK	Equipment

(Signature of Authorized Representative with official seal)

Date:

Name:

Designation:

Note: Please add additional pages if required.



ANNEXURE-8: CONFIRMATION BY BIDDER & CHECKLIST FOR BID SUBMISSION

1. **Name of the Bidder:**
2. **Job Description:**
3. **Tender Reference:**

Bid Number	
Job Title:	
Bidder's Name	
Proprietorship / Partnership / JV / Consortium	
Bidder's Address	
Phone	
E-mail	
Vendor Regn No. with GRSE (if applicable)	
MSME / MSE (Details if applicable)	
NSIC (Registration Details & Certificate Number, if applicable)	
GST Registration	
PAN No.	
GEM UNIQUE SELLER ID	
TreDS Regn No.	
PF Details	
ESI Details	
ROC/ Trade Licence	
Joint Venture/ Consortium agreement (if applicable)	
EMD (Details of Instrument, if applicable)	
ACCEPTANCE MATRIX FOR NIT [indicate SUBMITTED (WITHOUT DEVIATION) / SUBMITTED (WITH DEVIATION) / NOT SUBMITTED]	
ACCEPTANCE MATRIX FOR STAC [indicate SUBMITTED (WITHOUT DEVIATION), SUBMITTED (WITH DEVIATION), NOT SUBMITTED]	
ACCEPTANCE MATRIX FOR SOTR [indicate SUBMITTED (WITHOUT DEVIATION), SUBMITTED (WITH DEVIATION), NOT SUBMITTED]	
FORMAT FOR TECHNICAL ELIGIBILITY [indicate SUBMITTED / NOT SUBMITTED]	
DISCLOSURE BY CONTRACTOR OF EXISTING WORK [indicate SUBMITTED / NOT SUBMITTED]	
FORMAT FOR FINANCIAL ELEGIBILITY CRITERIA [indicate SUBMITTED / NOT SUBMITTED]	
AVERAGE ANNUAL TURNOVER FOR LAST 3 FINANCIAL YEARS ENDING ON 31-Mar-2022	
TURNOVER FOR FY 2021-22	
TURNOVER FOR FY 2020-21	
TURNOVER FOR FY 2021-22	
Submission of DOCUMENTS IN SUPPORT OF FINANCIAL ELIGIBILITY CRITERIA [indicate SUBMITTED / NOT SUBMITTED]	
SELF-CERTIFICATION FOR DECLARATION REGARDING BLACKLISTING/ TENDER HOLIDAY [indicate SUBMITTED / NOT SUBMITTED and if put on Tender Holiday / Blacklisted]	
NON-DISCLOSURE AGREEMENT (in non-judicial stamp paper of Rs 100/-) [indicate SUBMITTED / NOT SUBMITTED and reference No. if any]	
INTIGRITY PACT (in non-judicial stamp paper of Rs 100/-) [indicate SUBMITTED / NOT SUBMITTED and reference No. if any]	

(Signature of Authorized Representative with official seal)

Date:

Name:

Designation:

**ANNEXURE-9: CHECK LIST FOR BILL SUBMISSION - for Service Contracts****CHECK LIST FOR BILL SUBMISSION - for Service Contracts****A. GENERAL PARTICULARS: (to be checked and submitted by Contractor/Vendor)**

- A.1 BTN (as per BTS System):-
 A.2 Invoice No and date / E-Invoice No. & Date (if applicable for the vendor)
 (Original & in triplicate)
 A.3 PO Number
 A.4 Name of Vendor
 A.5 Location of work: MW / RBD/ FOJ/ TU / 61Park/Vendor's premises

I. For RA Bill (Running/Progressive bill) (Put \checkmark Mark)		YES	NO	NA
A.6	PO Number and date verified with Invoice:			
A.7	Vendor Name & Address in Invoice verified with Purchase Order:			
A.8	Vendor Code as in PO verified with Invoice:			
A.9	Original certified WDC enclosed :			
A.10	Whether WDC is Certified by the Authorized Person as per PO / SOTR with Rubber Stamp			
A.12	HSN/SAC code is as per PO			
A.13	GSTIN No. is as per PO			
A.14	GST % is as per PO			
A.15	Security Deposit (SD) submitted as per PO			
A.16	PBG of equivalent amount submitted, as per PO			
A.17	Compliance of Statutory Liabilities of labour as per PO			
II. Applicable for Final/Balance Bill (Put \checkmark Mark)				
A.20	Certified Job Completion Certificate (JCC) enclosed			
A.21	MRS as per PO terms enclosed (If applicable)			
A.22	Guarantee Period (GP) expired as per PO term			
A.23	PBG of equivalent amount submitted, if GP is not over (If Yes, copy to enclose with the bill)			

 Signature of Vendor's representative
 with Seal/Stamp

For GRSE Use Only

B.	To be checked and verified by Bill certifying authority (Put \checkmark Mark)	YES	NO	NA
B.1	Whether Bill has been forwarded through BTS			
B.2	Whether WDC is Certified by the Authorized Person as per PO / SOTR with Rubber Stamp			
B.3	Job starting & Completion Date (Schedule & Actual) indicated in WDC			
B.4	Certification of Penalty/ Recovery from bill indicated in WDC, if applicable			
B.5	Whether Bill is Certified by the Authorized Person as per PO / SOTR with Rubber Stamp			
B.6	Certification of Penalty/ Recovery from bill as per WDC, if applicable			
B.7	Service Entry Sheet (SES)/GR in line with WDC, PO & Invoice			
For Final/Balance Bill (Put \checkmark Mark)				
B.8	Certified MRS copy as per PO terms enclosed (If applicable)			
B.9	Guarantee Period (GP) expired as per PO term and JCC			
B.10	PBG copy of equivalent amount till GP validity enclosed (if GP is not over)			

 Signature of GRSE Bill Certifying Authority
 with Designation



during the execution of the contract.

b. The Bidder(s)/Contractor(s) will not enter with other Bidders into any undisclosed agreement or understanding, whether formal or informal. This applies in particular to prices, specifications, certifications, subsidiary contracts, submission or non-submission of bids or any other actions to restrict competitiveness or to introduce cartelization in the bidding process.

c. The Bidder(s)/Contractor(s) will not commit any offence under the relevant IPC/PC Act, further the Bidder(s)/Contractor(s) will not use improperly, for purpose of competition or personal gain, or pass on to others, any information or document provided by the principal as part of the business relationship, regarding plans, technical proposals and business details, including information contained or transmitted electronically.

d. The Bidder(s)/Contractor(s) of foreign origin shall disclose the name and address of the Agents/representatives in India, if any. Similarly, the Bidder(s) / Contractor(s) of Indian Nationality shall furnish the name and address of the foreign particulars, if any. Further details as mentioned in the "Guidelines on Indian agents of Foreign suppliers" shall be disclosed by the Bidder(s)/Contractor(s). Further as mentioned in the Guidelines all the payments made to the Indian agent/representative have to be in Indian Rupees only, copy of the "Guidelines on Indian agent of foreign supplier" is annexed and marked as annex.

e. The Bidder(s)/Contractor(S) will, when presenting his bid, disclose any and all payments he has made, is committed to or intends to make to agents, brokers or any other intermediaries in connection with the award of the contract.

[2] The Bidders(s)/ Contractor(s) will not instigate third persons to commit offences, outline above or be an accessory to such offence.

Section 3- Disqualification from tender process and exclusion from future contracts.

If the Bidder(s)/Contractor(s) before award or during execution has committed a transgression through a violation of Section 2, above or in any other form such as to put his reliability or credibility in question, the principal is entitled to disqualify the Bidders(s)/ Contractor(s) from the tender process or take action as per the extant procedure of the company.

Section 4- Compensation for Damages.

1) If the principal has disqualified the Bidder(s) from the tender process prior to the award according to section 3, the principal is entitled to demand and recover the damages equivalent to earnest Money deposit/Bid security.

2) If the Principal has terminated the contract according to section 3, or if the principal is entitled to terminate the contract according to section 3, the Principal shall be entitled to demand and recover from the contractor liquidated damages of the contract value or the amount equivalent to Performance Bank Guarantee.

Section 5- Previous Transgression

1) The Bidder declares that no previous transgressions occurred in the last 3 years with any other company in any country conforming to the anti-corruption approach or with any other Public Sector Enterprise in India that could justify his exclusion from the tender process.

2) If the Bidder makes incorrect statement on this subject he can be disqualified from the tender process or action can be taken as per the procedure mentioned in "Guidelines on Banning of business dealing"



Section 6- Equal treatment of all Bidders/Contractors/Sub-contractors.

- 1) The Bidder(s)/Contractor(s) undertake(s) to demand from all sub-contractors a commitment in conformity with this integrity pact, and to submit it to the principal before contract signing.
- 2) The principal will enter into agreements with identical conditions as this one with all Bidders, Contractors and Sub-Contractors.
- 3) The Principal will disqualify from the tender process all bidders who do not sign this pact or violates its provisions.

Section 7- Criminal charges against violating Bidder(s) Contractor(s)/Sub-Contractor(s)

If the principal obtains knowledge of conduct of a Bidder, contractor or subcontractor, or of an employee or a representative or an associate of a Bidder, Contractor or Sub contractor which constitutes corruption, or if the principal has substantive suspicion in this regard, the principal will inform the same to the Chief Vigilance Officer.

Section 8- Independent External Monitor/Monitors

- 1) The Principal appoints competent and credible Independent External Monitor for this pact. The task of the Monitor is to review independently and objectively, whether and to what extent the parties comply with the obligations under this agreement.
- 2) The Monitor is not subject to instructions by the representative of the parties and perform his functions neutrally and independently. He reports to the Chairman GRSE.
- 3) The Bidder(s)/Contractor (s) accepts that the Monitor has the right to access without restriction to all project documentation of the principal including that provided by the contractor. The contractor will also grant the Monitor, upon his request and demonstration of a valid interest, unrestricted and unconditional access to his project documentation. The same is applicable to subcontractors. The Monitor is under contractual obligation to treat the information and documents of the Bidder(s)/ Contractor(s) /Subcontractor(s) with confidentiality.
- 4) The Principal will provide to the Monitor sufficient information about all meeting among the parties related to the project provided such meetings could have an impact on the contractual relations between the principal and the contractor, The parties offer to the Monitor the option to participate in such meetings.
- 5) As soon as the Monitor notices, or believes to notice, a violation of this agreement, he will so inform the management of the principal and request the management to discontinue or take corrective action, or to take other relevant action. The Monitor can in this regard submit non-binding recommendations. Beyond this the Monitor has no right to demand from the parties that they act in a specific manner, refrain from action or tolerate action.
- 6) The Monitor will submit a written report to the Chairman, GRSE within 8 to 10 weeks from the date of reference or intimation to him by the principal and should the occasion arise, submit proposals for correcting problematic situations.
- 7) Monitor shall be entitled to compensation on the same terms as being extended to/provided to Independent Directors on the GRSE Board.
- 8) If the Monitor has reported to the Chairman GRSE a substantiated suspicion of an offence under



relevant IPC/PC act, and the Chairman GRSE has not, within the reasonable time taken visible action to proceed against such offence or reported it to the Chief Vigilance Officer, the Monitor may also transmit this information directly to the Central Vigilance Commissioner.

9) The word 'Monitor' would include both Singular and plural.

Section 9- Pact Duration:

This pact begins, when both parties have legally signed it. It expires for the contractor 18 months after the last payment under the contract, and for all other Bidders 6 months after the contract has been awarded.

If any claim is made/lodged during this time, the same shall be binding and continue to be valid despite the lapse of this pact as specified above, unless it is discharged/determined by Chairman of GRSE.

Section 10- Other provisions:

- 1) This agreement is subject to Indian Law, place of performance and jurisdiction is the Registered Office of the principal i.e. Kolkata.
- 2) Changes and supplements as well as termination notices need to be made in writing. Side agreements have not been made.
- 3) If the Contractor is a partnership or a consortium, this agreement must be signed by all partners or consortium members.
- 4) Should one or several provisions of this agreement turn out to be invalid, the remainder of this agreement remains valid. In this case, the parties will strive to come to an agreement to their original intentions.

(For & On behalf of the principal)

(For & On behalf of the Bidder/Contractor)

Place

Place

Date

Date

Witness 1
(Signature, Name & Address)

Witness 2
(Signature, Name & Address)



ANNEXURE-12: NON-DISCLOSURE AGREEMENT
(to be executed in Non-Judicial Stamp Paper of Rs.100/-)

This Non-Disclosure Agreement executed thisDay of2021.

Between

GARDEN REACH SHIPBUILDERS & ENGINEERS LIMITED, a company incorporated under the provisions of the Companies Act, 1956, having its Registered Office at 43/46, Garden Reach Road, Kolkata – 700024, hereinafter referred to as “**GRSE**” (which expression shall unless excluded by or repugnant to the subject or context be deemed to mean and include its successors-in-interest, administrators and assigns) of the **FIRST PART**.

AND

M/s _____ (with full address), hereinafter referred to as the L1 Bidder (which expression shall unless excluded by or repugnant to the subject or context be deemed to mean and include its successors-in –interest, administrators and assigns) of the **SECOND PART**.

WHEREAS

For purpose of this Agreement, GRSE discloses (herein after referred to as the “Disclosing Party”) to the Bidder (herein after referred to as ‘Recipient’) Confidential Information as are required to give effect to the terms of the NIT/Purchase Order and the Recipient receives and or accesses the said Confidential Information

WHEREAS The Bidder being considered inter alia for the purpose of _____ work and as such some of the data, drawings/documents in connection with construction of Anti-Submarine Warfare Shallow Water Craft (ASW SWC) are required to be disclosed which shall be treated as confidential and the said Recipient, shall not disclose or part with such drawings/documents either whole or in part to any other third party, without prior written consent from GRSE.

AND WHEREAS the said Recipient, is obliged to execute an undertaking in the form of “Non-Disclosure Agreement” on receiving Confidential Information in the form of data drawings/ documents and also confidential/proprietary drawings or technical information of Indian Navy through Government of India or any other party, as the case may be, by GRSE, duly promising and/or undertaking to keep and treat such data, drawings/documents as strictly ‘confidential’.

NOW THEREFORE both GRSE and the Bidder do hereby agree as follows in the premises aforesaid: -

1. In the Premises aforesaid it is agreed as follows:
 - (a) “Confidential Information” means and includes any and all facts, knowledge, information, data and drawings and documents of any nature whatsoever, whether written or electronic mode owned and/or possessed by GRSE notwithstanding it belongs to any person, government or otherwise not limited to ideas, designs, data, source code, processes, computer programming, flow diagrams, know how, computer programming and other software and software techniques and such other notes, interpretation, derivative or analysis of data that has been or may hereafter be provided or shown to the Recipient or is gathered, received or obtained directly or is otherwise obtained from the review of GRSE’s documents. It is agreed that any and all reports, notes, minutes, summaries, flow charts, diagrams and any other information that is prepared based on the discussions and interaction with GRSE pursuant to this Agreement shall be deemed to be Confidential Information under this Agreement.
 - (b) During the pre-bid discussion and subsequent agreement between the parties herein, if any, for execution of the job and also for a period of 10 years from the date of Expiry and/or foreclosure and/or termination of the said NIT/PO, M/s _____, the Recipient, undertakes that the Confidential Information so received in any form whatsoever shall be:



- i) Protected and kept as strictly confidential by them.
 - ii) Disclose to and used only by the persons within the organization of M/s_____, who have a need to know solely for the purpose of pre-bid meeting and for execution of the work if awarded by GRSE subsequently subject to their taking due care and protection of the system and data.
 - iii) Used in whole or in part solely for the purpose of pre-bid meeting and for execution of the work if awarded by GRSE subsequently in the manner as ordered by GRSE or to be ordered from time to time exclusively and shall not be exploited for any other purpose or customers.
 - iv) Neither be disclosed nor cause to be disclosed directly or indirectly to any third party.
 - v) Neither be copied nor otherwise be reproduced, in whole or in part without prior express consent from GRSE.
 - vi) Returned to GRSE forthwith on demand at any point of time and upon immediate foreclosure /expiry of the contract if subsequently entered.
2. Nothing in this agreement or the disclosure of the Confidential Information or data or systems, to be intended to be granted or shall be construed as granting to the Recipient., any rights, title, interest or license other than the right to use such Confidential Information for the purpose of pre-bid meeting and for the execution of the contract/job if subsequently awarded by GRSE and shall not be exploited for any other purpose or customers of the Recipient. In this regard for the purpose of pre-bid meeting or for execution of job if any, to be subsequently awarded by GRSE to the Recipient shall at all times remain the exclusive property of GRSE and rest with GRSE.
 3. The Recipient shall resort to any publicity or advertising in respect of this agreement or the subject matter thereof and the subject matter of PO and/ or any Agreement, if any, to be entered into subsequently.
 4. The Recipient shall not make any copies or duplicate or reduce in writing the Confidential Information or part thereof in anyway in whole or part any information without the prior written consent of GRSE and where such copies or reproductions are permitted in accordance with this clause, the Recipient shall treat them strictly confidential in accordance with the provisions of this agreement and comply with the instructions of GRSE with regard to the protection and disposal of them.
 5. If the Recipient is compelled under any law to disclose (whether by way of announce or otherwise) any Confidential Information, it shall give prompt notice in writing of such fact to GRSE and shall provide all cooperation and assistance as may be requested by GRSE in order to seek an appropriate remedy to prevent or restrict such disclosure.
 6. It is agreed by the Recipient that the Recipient shall take full responsibility while handling the Confidential Information provided by GRSE, which means that the Recipient shall be fully responsible of the acts of its employees/subcontractors/officers/associates who are required to handle the Confidential Information provided by GRSE.
 7. **Indemnity:** Recipient shall indemnify GRSE and hold harmless from and against all actions, proceedings, claims, demands, losses, damages, costs (including between attorney and clients) charges, expenses and consequences whatsoever that may be brought or made against or sustained or incurred by GRSE in consequences resulting from any act or omission on the part of Recipient including its employees/subcontractors/officers/associates.
 8. The Recipient agrees and undertakes GRSE that the Recipient shall obtain appropriate indemnity from its sub-contractors and outside personnel/workers to the effect that they will use Confidential Information for construction of the ships only and for no other purpose and also, they would not divulge or pass on any Confidential Information to any third party for any reason whatsoever.
 9. The Recipient acknowledges the competitive value and confidential nature of the Confidential Information and the resultant damage to GRSE if the Confidential Information is disclosed or allowed to be disclosed to any unauthorized persons or used for the purpose of violation of this Agreement. The Recipient confirms that it is imperative that all Confidential Information remains confidential. The Recipient acknowledges that GRSE possesses Intellectual Property Rights in the Confidential Information.



10. The expiry, foreclosure or termination of the PO or any or all of the subsequent agreements entered into by GRSE and the Recipient, if any, in pursuance of the pre-bid discussion, shall not relieve the Recipient of their/its obligations under these presents which shall be effective and remain effective and in full force, for a period of 10 years from the date of such expiry/foreclosure/termination of the PO.
11. In the event of expiry, foreclosure or termination, the Recipient shall forthwith return to GRSE, the Confidential Information as received by them/it during tenure of the PO and/or subsequent agreements.
12. Neither party shall assign any PO and / or any Agreement, if any, to be subsequently entered into, without the written consent of the other and should there be any re-organization, merger, take over or the like, its successor-in-interest shall be bound by the conditions of this Agreement.
13. Failure to enforce any provision of this agreement and/or failure to initiate timely action, will not construe to be waiver and GRSE shall be freely entitled to enforce the provisions of this agreement at any appropriate time thereafter.
14. In the event any provision of this Agreement shall be held invalid or unenforceable for any reason, that provision shall not affect any other provision of this Agreement.
15. The Recipient acknowledges that Confidential Information belonging to GRSE is a valuable asset. Disclosure in breach of this Agreement will result in irreparable injury to GRSE for which monetary damage alone will not be an adequate remedy. Therefore, the parties agree that in the event of a breach or threatened breach of the terms of this Agreement, GRSE will be entitled to specific performance, injunctive relief or other equitable relief prohibiting any breach of this Agreement. Any such equitable remedy shall be in addition to and not in lieu of, other appropriate relief at law which GRSE may be entitled.
16. This agreement shall be governed under the Indian Laws and the Courts in Kolkata shall have exclusive jurisdiction to try determine and adjudicate any disputes arising between the parties in relation to this agreement.
17. GRSE' standard arbitration clause as contained in NIT shall apply to this agreement for resolution of disputes between the parties.

IN WITNESS WHEREOF the parties have hereunto set and subscribed their respective hands and seals on the day, month and year first above written.

**FOR GARDEN REACH SHIPBUILDERS &
ENGINEERS LTD**

FOR M/s _____,

Signature:
Name:
Address:

Signature:
Name:
Address:

WITNESS 1

WITNESS 2

Signature:
Name:
Address:

Signature:
Name:
Address :



**CHECK LIST OF STATUTORY RESPONSIBILITY OF CONTRACTOR
THE CONTRACT LABOUR (R& A), ACT, 1970 AND CENTRAL RULES, 1971**

SL. NO.	NATURE OF STATUTORY REQUIREMENTS	FORM NO.	RESPONSIBILITY	REMARKS
01	Labour License	Form –II	Contractor	Contractors engaging 20 or more contract labours would apply for obtaining labour license (in triplicate) to the ALC (C), Kolkata. A copy of the license should be submitted to concerned Unit HR Department. <i>Note:</i> The Contractor cannot deploy more than the number of workmen mentioned in the license on any day.
02	Renewal of labour license	Form –II	Contractor	The contractor shall apply to the ALC(C), Kolkata for renewal of license at least 30 days prior to its expiry. A copy of the acknowledgement / renewed license should be submitted to concerned Unit HR Department.
03	Notice for commencement / completion of work	Form-VII	Contractor / Principal Employer	The contractor shall submit Form – VII to the Inspector / Labour Enforcement Officer (C), Kolkata within 15 days intimating the actual date of commencement / completion of the work. The receipted copy of Form – VII should be submitted to concerned Unit HR Department.
MAINTENANCE OF REGISTERS				
04	Employee Register	FORM – A	Contractor	Comprising of personal details like name, father's name, DOB, Address etc. of the workmen engaged by the contractor.
05	Wages Payment Register	FORM – B	Contractor	Comprising of current rate of minimum wages, employees PF & ESI contribution and other allowances, if any.
06	Register of Loan / Recoveries / Fines etc.	FORM – C	Contractor	To maintain record of loans, fines and advances given, if any and monthly record of recoveries.
07	Attendance Registers	FORM – D	Contractor	Data of daily attendance of each workmen engaged by the contractor indicating their in and out time.



SL. NO.	NATURE OF STATUTORY REQUIREMENTS	FORM NO.	RESPONSIBILITY	REMARKS
08	Employment Card	Form – XII	Contractor	Every contractor shall issue employment card / appointment letter to their contract workers within 03 days from their date of employment.
09	Service Certificate	Form – VIII	Contractor	To be issued by the contractor upon termination of employment / completion of work etc.
10	Wage-slip	Form – XIX	Contractor	Contractors shall issue wage-slip to their workmen at least 01 day prior to disbursement of wages.
11	Annual Return	Online Submission	Contractor	Every Contractors shall prepare Annual Return for the previous year which is submitted online by the Contractors' in <i>Shram Suvidha</i> Portal to the Registering Officer within 31st Jan of the following year.



**CHECK LIST OF STATUTORY RESPONSIBILITY OF CONTRACTOR
COMPLIANCE OF OTHER STATUES FOR ENGAGEMENT OF CONTRACTORS' WORKMEN**

Sl. No.	Relevant Statues	Responsibility	Compliances to be ensured as per the Statute
01	The Factories Act, 1948 & West Bengal Factories Rules, 1958	Contractor	<p>1. <u>Leave with Wages</u>: Every worker who has worked for a period of 240 days or more is entitled to get leave with wages to be calculated one day for every 20 days of work performed by him.</p> <p>2. <u>Payment of Overtime</u>: Where a worker has worked for more than 09 hours in any day or for more than 48 hours in a week, he shall, in respect of overtime work, be entitled to wages twice the hourly rate.</p> <p>3. <u>Hours of Work</u>: The total nos. of hours of work in a week, including overtime, shall not exceed sixty.</p> <p>4. <u>Hours of Overtime</u>: The total hours of overtime shall not exceed fifty in any quarter i.e. during three consecutive months for any worker.</p>
02	Payment of Wages Act, 1936	Contractor	Contractors (employer) engaging less than 1,000 persons have to pay wages before expiry of the 7th day after the last day of wage period.
03	The Minimum Wages Act, 1948	Contractor	Contractors (employer) shall pay minimum wages to every worker as per the Central rates circulated by the Management from time to time.
04	The EPF & MP Act, 1952	Contractor	<p>1. Every contractor shall obtain the following before commencement of work:</p> <p>(a) PF Code No. of the firm.</p> <p>(b) PF UAN i.r.o of the workmen engaged by him.</p> <p>(c) Ensure submission of nominee and dependent details while applying for UAN of workmen.</p>
		Contractor	<p>2. Every contractor shall contribute towards PF @ 12% of the monthly wages of each workman as employer's share and recover 12% of monthly wages from each employee, as employees share and thereafter remit the entire amount to EPFO i.r.o every workman engaged by him. The contribution for the preceding month should be remitted prior to expiry of the 15th day of the following month. Contractors (Employers) are also required to bear the administrative charges as applicable.</p>



Sl. No.	Relevant Statues	Responsibility	Compliances to be ensured as per the Statute
05	The ESI Act, 1948	Contractor	1. Every contractor shall obtain the following: a) ESI Code No. of the firm (b) ESI code no. i.r.o of the workmen engaged by him (c) Ensure submission of nominee and dependent details while applying for ESI TIC (E-Pehchan Card).
		Contractor	2. Every contractor shall remit ESI contribution (employers' share @ 3.25% and employees' share @ 0.75%) i.r.o every workman engaged by him for the preceding month prior to expiry of the 15th day of the following month.
06	The Payment of Bonus Act 1965 & Rules	Contractor	1. Contractors shall pay annual bonus to their workmen (Contract Labour) drawing wages below and upto Rs. 21,000/- per month. Bonus will be payable minimum @ 8.33% and maximum @ 20% of annual wages.
		Contractor	2. Register in Form - C format {Rule 4(b)} of 'The Payment of Bonus Act, 1965' is to be maintained by the contractor for submission of Annual Return as per the Act.



RESPONSIBILITIES OF CONTRACTORS OVER AND ABOVE THE STATUTORY REQUIREMENTS

- (i) Contractors shall take all necessary steps for disbursement of wages through bank-transfer and issue a payment notice at least 02 days prior to such bank-transfer for information of respective unit HR Dept. as well his workers. (should be incorporated in the contract document in the Payment Terms).
- (ii) All contractors should obtain labour-licenses prior to commencement of work. Principal Employer shall not allow any contractor without license.
- (iii) All outsourced jobs are required to be supervised by a Supervisor duly appointed by the Contractor. The contractor should declare the name and contact number of the supervisor(s) against each P.O before commencement of work and submit the details of the supervisor(s) to the respective unit HR Department. He should keep adequate nos. of supervisors to supervise and co-ordinate the execution of job by contract labours. (The principal employer must check that the name and number of the supervisor which has been provided by the contractor, whether the same person is coming as the said supervisor).
- (iv) The supervisor's name should not be mentioned in the employee register as he is not a contract labour.
- (v) Supervisor of concerned contractor should be present in the work-site where the contract labours of the concerned contractor are supposed to work. To ensure the presence of the supervisor, their attendance may be recorded by the user department on daily basis.
- (vi) Contractor should mention the name of his Supervisor / agent / manager in Form-II which is to be submitted to ALC (C) for obtaining labour license.
- (vii) The supervisor should maintain the attendance register of their contract labours (Form-D) which may be randomly checked by the Officers of the user department. This attendance register will be submitted by the contractors on monthly basis along with the wages-payment registers to the respective unit HR Depts. for obtaining certification of payment of wages to each contractor labour based on their daily / monthly attendances.
- (viii) Contractors must submit details of their firms in the Appendix B1 format prior to commencement of work. They must also submit details of their contract labours in B2 formats for making new gate-passes for the purpose of entry / exit prior to the engagement of such contract labour.
