



GARDEN REACH SHIPBUILDERS & ENGINEERS LTD.

गार्डन रीच शिपबिल्डर्स एण्ड इंजीनियर्स लिमिटेड
(A GOVERNMENT OF INDIA UNDERTAKING)
भारत सरकार का प्रतिष्ठान

61, Garden Reach Road, Kolkata-700 024
61, गार्डन रीच रोड, कोलकाता 700 024

Phone दूरभाष: (033) 2469-8100 to 8113 Extn. बिस्तार: 225, FAX फैक्स: (033) 2469 3932

Web site वेब: www.grse.in

CIN सी आई एन: L35111WB1934GOI007891

NOTICE INVITING TENDER (NIT)

निविदा आमंत्रण सूचना

Garden Reach Shipbuilders & Engineers Limited, a leading Warship Builders and Engineering Product Company, invites interested, reputed, resourceful and financially solvent Service provider to submit **single stage two-part (Part I- Techno-Commercial & Part II- Price) bids** through e-tendering mode for the work package as per following bid document.

NIT No. निविदा संख्या :	SCC/AJK/OT(PRESS)/HARD STAND RBD/CAP/012/ET-3024 Date: 27.06.2024
Job Title कार्य का नाम:	CONSTRUCTION OF REINFORCED CONCRETE HARD STAND / PAVEMENT WITH ASSOCIATED CIVIL WORKS AT VARIOUS LOCATIONS WITHIN RBD UNIT, GRSE LTD, KOLKATA [to be executed as per SOTR No. YM/4/SOTR/RBD/HS-2(RT)/2024 dt.05.06.2024]
Tender issuing Dept. बिभाग द्वारा जारी:	Contract Cell संविदा बिभाग (GRSE Main)

ARTICLE 1 अनुच्छेद-1: SCHEDULE OF CALENDAR DATES समायावली की अनुसूची:

SCHEDULE सारणी		
Pre Bid Meeting (if applicable) बोली-पूर्व बैठक (यदि लागु है)	08-07-2024	11.00 Hrs.
Tender Due Date निविदा जमा की अंतिम तिथी	19-07-2024	12:00 Hrs.
Tender Opening Date (Part I) निविदा खुलने की तिथी	22-07-2024	14:00 Hrs.
Offer Validity Period minimum ऑफर की नियुक्तम वैधता अवधी	90 Days from Tender due date	

ARTICLE 2 अनुच्छेद-2: COMMERCIAL REQUIREMENT FOR THE NIT निविदा की ब्यवसायिक आवश्यकता:

FEES / DEPOSITS	
Tender Fee (refer clause 03 of STAC) निविदाप्रपत्र मुल्य (स्टैक के परिच्छेद 03 मे उदधृत)	INR 500 (Rupees Five Hundred only)
Earnest Money Deposit (EMD) (refer clause 04 of STAC) बयाना राशि जमा (स्टैक के परिच्छेद 04 मे उदधृत)	INR 10,00,000/- (Rupees Ten Lakhs Only)
Security Deposit (SD) प्रतिभूति	5% of Order Value (incl. GST)
PBG पी बी जी	10% of Order Value (incl. GST)
Liquidated Damages परिनिर्धारित नुकसान	½ % per week max. 5 % of unexecuted job
Billing Frequency बिल करने की अवधी	Monthly Running Bill basis (until completion)
Evaluation of L1 एल1 का मूल्यांकन	L1 bidder will be decided on Totality

Note: - 1. Attending Pre-Bid meeting and site visit is mandatory for participation against this tender as per SOTR. Any bid received from any vendor who has not attended pre bid meeting and did not visit the site will not be considered for processing of the tender. If for any reason physical attendance is not possible, pre bid meeting can be attended via video conference and site visit can be attended through video call and in that case prior intimation has to be given at least one day before Pre-Bid meeting. For pre bid meeting, please contact Sri. Tanay Saha, DGM (YM) mob:76030 39445/ E-mail: Saha.Tanay@grse.co.in

2. Bidders are required to submit EMD amount as Bid Security in the form of DD/ Pay Order against this tender as per the Clause Ref. (2) of STAC, Enclosure-2. In case of withdrawal of the bid/ fail or refuse to execute the contract / fail or refuse to furnish the security deposit, the EMD shall liable to be forfeited.

MSE/NSIC registered firms having the tendered service listed in their MSE document will be eligible for exemption from submitting the EMD.

Non-submission of EMD or a valid MSE/NSIC certificate may lead to offer rejection.

The submission of EMD instrument is MANDATORY for joint-venture or consortium of two or more firms and there shall be no exemption applicable against submission of NSIC/MSE certificates by the firms.

3. The Registration Number allotted to MSME's by Trades Receivable e-Discounting System (TReDS) to be furnished. Non submission TReDS registration no. by MSME registered firm may lead to offer rejection.

4. Note: Relaxation on prior experience and prior turnover to MSE / Start-up shall not be applicable for this tender.

ARTICLE 3 अनुच्छेद-3: ANNEXURES FORMS PART OF THIS TENDER निविदा की संलग्नक प्रपत्र:

ARTICLES ENCLOSED FORMING PART OF THIS e-TENDER ई-निविदा अंतर्गत संलग्नक परिच्छेद		
Annexure 1 संलग्नक-1	Statement of Technical Requirement (SOTR) and Special Terms and Conditions	Yes
Annexure 2 संलग्नक-2	GRSE Standard Terms And Conditions (STAC) (please refer www.grse.nic.in)	Yes
Annexure 3 संलग्नक-3	Format for - Integrity Pact (please refer www.grse.nic.in)	Yes
Annexure 4 संलग्नक-4	Format for Technical Eligibility Criteria (Attached with NIT)	Yes
Annexure 5 संलग्नक-5	Format for Financial Eligibility Criteria (Attached with NIT)	Yes
Annexure 6 संलग्नक-6	Format for Self Certification (Attached with NIT)	Yes
Annexure 7 संलग्नक-7	Fire & Safety Guidelines (please refer www.grse.nic.in)	Yes
Annexure 8 संलग्नक-8	Special condition of contract (please refer www.grse.nic.in)	Yes
Annexure 9 संलग्नक-9	Contractors Responsibility (please refer www.grse.nic.in)	Yes
Annexure 10 संलग्नक-10	General Requirement (please refer www.grse.nic.in)	Yes
Annexure 11 संलग्नक-11	Check List for Bill submission (please refer www.grse.nic.in)	Yes
Annexure 12 संलग्नक-12	Format for - Bank Guarantee Format for EMD (please refer www.grse.in) → Tender → Enclosures Related to tenders of Sub-Contracting Activities)	Yes
Annexure 13 संलग्नक-13	Format for - Bank Guarantee Format for SD (please refer www.grse.nic.in)	Yes
Annexure 14 संलग्नक-14	Format for - Bank Guarantee Format for PBG (please refer www.grse.nic.in)	Yes
Annexure 15 संलग्नक-15	Guide line for Bank Guarantee (please refer www.grse.nic.in)	Yes

ARTICLE 4 अनुच्छेद-4: DOCUMENTS TO BE UPLOADED अपलोड हेतु दस्तावेज:

Self-Attested documents are to be scanned and uploaded with Part I of e-bid ई-बिड के भाग-1 के साथ स्कैन एवं अपलोड हेतु स्वअभिप्रामाणित दस्तावेज		
1	DD/PO or MSE/NSIC Exemption certificate towards tender fee	Yes
2	Technical Acceptance format as available with NIT after being downloaded and filled up	Yes
3	Commercial Acceptance Format as available with NIT after being downloaded and filled up	Yes
4	Documents meeting the Technical Eligibility Criteria as per format at Annexure-4	Yes
5	Documents meeting the Financial Eligibility Criteria as per format at Annexure-5	Yes
6	Audited/Certified Annual Accounts and Annual Report for immediate last three years in support of Financial Eligibility.	Yes
7	PAN /TAN , GST , Labour License Certificate , Registration Certificate of the Company with ROC	Yes
8	Integrity Pact (refer clause 01 of STAC)	Yes

9	Partnership Deed / Memorandum and the Article of Association of the firm confirming partners and lead partner	Yes
10	Government E-Market Place (GeM) registration certificate with Unique GeM Seller ID	Yes
11	Registration Number allotted to MSME's by Trades Receivable e-Discounting System (TReDS)	Yes

- Registered Bidders with GRSE need not upload para 7 documents if valid documents already submitted / available with GRSE Vendor Registration Cell.
- Winning Bidder may submit ink signed hard copy of all above documents, prior to issuance of PO.

ARTICLE 5 अनुच्छेद-5: DOCUMENTS IN PHYSICAL FORM TO SUBMIT वास्तविक प्रपत्र जो जमा करने हैं:

PHYSICAL SUBMISSION		
1	Tender Fee instrument	Within 03 days from opening of Part-I bid
2	EMD Instrument	Within 03 days from opening of Part I bid
NOTE:	If instruments submitted through demand draft, the same to be drawn in favour of :	GARDEN REACH SHIPBUILDERS & ENGINEERS LIMITED
	The demand drafts should be payable at	Kolkata
3	Integrity Pact	Within 03 days from opening of Part I bid

- Above original Negotiable Instruments as stipulated, to reach to Mr. A. J. Kandir, SM (Contract), Contract Cell, GRSE, 61 Park Unit within stipulated period as indicated above in a sealed envelope with tender number and job duly superscripting on it.

ARTICLE 6 अनुच्छेद-6: JOB EXECUTION SCHEDULE कार्य निष्पादन सूची:

- Mobilization period: - 15 days from the date of issue of LOA/PO whichever is earlier.
- Job Starting Date** कार्य आरम्भ तिथि: Job must be started on completion of mobilization period on receipt of LOA/ PO whichever is earlier.
- Job Completion date** कार्य समाप्ती तिथि: The entire job must be completed within **05 (Five) Calendar Months** from the date of issuance of LOA/ PO whichever is earlier on completion of mobilization period.

ARTICLE 7 अनुच्छेद-7: JOB EXECUTION कार्य निष्पादन:

"CONSTRUCTION OF REINFORCED CONCRETE HARD STAND / PAVEMENT WITH ASSOCIATED CIVIL WORKS AT VARIOUS LOCATIONS WITHIN RBD UNIT, GRSE LTD, KOLKATA" has to be carried out strictly as per SOTR No. YM/4/SOTR/RBD/HS-2(RT)/2024 enclosed herewith as Annexure - I.

In case of any doubt, instructions of the Officer in-charge (YM Dept.) is to be followed.

ARTICLE 8 अनुच्छेद-8: GURANTEE & WARRANTEE गारंटी एवं वारंटी:

The work executed including equipment or components thereof are to be guaranteed for satisfactory performance for the period of **12 (Twelve) Calendar months** from the date mentioned in the Completion Certificate, unless otherwise agreed in writing by the Engineer. This will be deemed as the 'Guarantee Period'/ 'Defect Liability Period'.

ARTICLE 9 अनुच्छेद-9: PRICE मूल्य:

Price quoted will be firm and fixed for the entire contract period till completion of work awarded during valid contract period. GST is to be indicated separately and will be paid extra. No escalation whatsoever will be considered under any circumstances within the stipulated period of contract.

ARTICLE 10 अनुच्छेद-10: ESCALATION मूल्य वृद्धि: Not Applicable

ARTICLE 11 अनुच्छेद-11: UNREASONABLE QUOTES अतर्कसंगत भाव:

- i. In case the price of L-1 Bidder is found to quote unreasonably low and/or express desires to withdraw from the tender then such bid will be cancelled and EMD will be forfeited and punitive action will be taken in line with the provision as per GRSE Vendor policy.
- ii. However, in case the L1 Bidder agrees to take-up the job with such unreasonable low quote, lower by 30% or more than estimate and also if the difference in price between L1 & L2 is 30% or more, then the quoted price to be analyzed w.r.t. tender requirement and if the L1 bidder fails to justify their quoted rate, the obtained L1 quote will be rejected and the tender will be cancelled. During re-tendering, such bidder with low quote will not be allowed for participation.
- iii. If justification is acceptable to GRSE, then Bidder have to submit a declaration to execute the job till satisfactory completion of entire contract. In case of breach of contract, GRSE shall reserve the right to impose Tender Holiday for a period of at least 01 year.

ARTICLE 12 अनुच्छेद-12: OFFER VALIDITY प्रस्ताव की वैधता:

Offer should be valid for 90 days from the date of opening of Part-I bid i.e. Techno-commercial bid. Under exceptional circumstances GRSE may request for extension of price validity, beyond 90 days against valid reason.

ARTICLE 13 अनुच्छेद-13: CONDITIONAL OFFER सशर्त प्रस्ताव:

Conditional offers w.r.t. SOTR will not be accepted. However, in case of bidder wish to deviate on any / some commercial terms & conditions, then separate deviation statement has to be uploaded along with Part-I bid. However, GRSE reserves the right to accept / reject the deviations / bid with deviations after giving reasonable opportunity to the Bidder.

ARTICLE 14 अनुच्छेद-14: DETERMINATION OF L1 एल-1 का चयन:

L1 bidder will be decided on total basic quote (Package 1 + Package 2).

ARTICLE 15 अनुच्छेद-15: BOQ बी ओ क्यू:

The quantity mentioned in BOQ may vary according to actual requirement of job during the period of contract. BOQ with item quantities for construction as part of SOTR are given in the tender is tentative. The quantities set out in the BOQ of the tender shall be treated as estimated quantities of the work and shall not be deemed as actual or correct quantities of the work to be executed by the Contractor.

The Contractor shall execute required quantity for successful completion of project work at the same contractual rates and terms & conditions for any extent of variation in stipulated BOQ quantities.

All bidders shall quote against all the items of BOQs, otherwise, their bid would be considered as Incomplete Bid and shall be liable for rejection.

ARTICLE 16 अनुच्छेद-16: OPENING OF BIDS निविदा खुलना:

Part-I (techno-commercial) bid will be opened on the date declared in NIT. Part-II bid will be opened post techno-commercial evaluation by GRSE. Price bid of only those who qualify techno-commercially will be opened. Opening date of Price Bid will be intimated accordingly to all qualified bidders. Disqualified bidders, either during technical assessment or commercial discussion will also be intimated about their non-consideration for farther processing.

ARTICLE 17 अनुच्छेद-17: MICRO & SMALL ENTERPRISES सूछ्छम एवं छोटे उद्योग:

Purchase preference may be given to eligible Micro and Small Enterprise Firms as per MSME Act provided, the tendered job is listed in their MSE document. (Detail at Clause 2 of STAC)

All Micro & small enterprises are required to declare their Udyog Aadhar Memorandum (UAM) number on the Central Public Procurement Portal (CPPP). Documentary evidence of the said declaration is to be submitted along with the techno-commercial bid failing which benefits being accorded to Micro & Small Enterprises will not be extended.

ARTICLE 18 अनुच्छेद-18: AWARDING JOBS TO MULTIPLE BIDDER बहुल बिडर के लिए ठेका कार्य:

GRSE is interested to execute the job through multiple bidders through distribution of BOQ (Package 1 & Package 2) amongst two bidders. L1 bidder will be offered Package 1. Package –2 will be offered to L2/L3..... bidder according to their ranking, at established L1 rate. In case if bidders other than L1 does not accept to execute the job of package – 2 at established L1 rate OR only one vendor is found eligible in the tender, then GRSE reserves the right to load both the packages (1 & 2) on L1 vendor and in such case L1 vendor have to execute the job of two packages.

ARTICLE 19 अनुच्छेद-19: ELIGIBILITY CRITERIA पात्रता के मापदंड:

Technical Eligibility Criteria तकनीकी मापदंड –

(a) Bidder shall have experience of successful execution of Similar Nature /Type of Job i.e. Construction of Concrete pavement/Hardstand, Construction of Building or Industrial Shed or any civil related structure including related civil work during last Seven (07) years. It may kindly be noted that value of Concreting and Reinforcement steel taken together (not structural steel) (including GST) should be at least 40% of total work order value (i.e. such value will be calculated by combining only the eligible orders as per Clause No 7.1.2 i.e. the total value of Concreting and Reinforcement of all eligible order should be at least 40% of total value of all eligible order), otherwise bidder will not be considered for evaluation. Supporting documents meeting Technical Eligibility Criteria to be submitted along with the bid. Also, full contact details like name, address, telephone numbers of the person under whose direct jurisdiction the work was executed etc.) to prove that they had carried out such works successfully in any PSU / Corporate house / Industry.

(b) Bidder has to fulfill experience in successful completion of aforesaid similar jobs of value (including GST) not less than Rs. 480 Lac for one job OR not less than Rs. 300 Lac each for two jobs OR not less than Rs.240 Lac each for three jobs in last Seven (07) years. The bidder must submit necessary proof duly endorsed along with the bid.

OR

Bidder has to fulfill experience in partial completion of aforesaid similar jobs of value (including GST) not less than Rs. 480 Lac for one job OR not less than Rs. 300 Lac each for two jobs OR not less than Rs.240 Lac each for three jobs in last Seven (07) years. The bidder must submit necessary proof for partial completion certificate indicating the aforesaid value as mentioned above duly endorsed from the engaging authority along with the bid.

Format for Technical Eligibility Criteria has been attached to this document as per format attached at Annexure - 4. The format has to be filled up and to be uploaded with the Techno-commercial Bid.

Note: Non-submission of documents along with Techno-commercial bid as mentioned in above clauses, the offer will not be considered for further tender processing /bidders not having requisite experience as established by their uploaded technical bids, may not be called for TNC.

Financial Eligibility Criteria वाणीजीक मापदंड –

- (i) Bidder should have average minimum Annual Turnover of Rs.300.0 Lakhs during last 03 (three) financial years ending on 31.03.2023.
- (ii) Audited Balance Sheet and Profit & Loss Account of the company for last 03 (three) financial years ending on 31.03.2023 need to be submitted in support of above requirement.
- (iii) Bidder shall provide Solvency Certificate for a sum of not less than Rs.300.0 Lakhs from Banker (any scheduled bank other than co-operative bank) required. Solvency certificate should not be 06 (Six) months old w.r.t. this tender opening date.

- (iv) The bidder should give self-certification (as per Annexure-6) that they have neither been Blacklisted nor have received any tender holiday from any PSUs/Central & State Govt. Organizations or any other Government / Quasi Government Organizations during last 03 (three) years ending on 31.03.2024. The bidder has to submit self-certification for the same along with the techno-commercial offer. GRSE reserves the right to independently verify the same. In case violation of declaration is detected at any stage of tender process and during currency of contract, the order will be terminated.

Note:

- a) If any bidder has been black listed by any PSUs/Central & State Govt. Organizations or any other Government / Quasi Government Organizations, then the bidder is not eligible to participate in this tender. If any discrepancy is detected at any stage of the tender, then the offer submitted by the bidder / contract awarded to the bidder will be cancelled and EMD/SD shall be forfeited and appropriate action will be taken in accordance with the vendor policy of GRSE.
- b) If any bidder has been 'Put on Tender Holiday' by any PSUs/Central & State Govt. Organizations or any other Government / Quasi Government Organizations, then this fact must be clearly stated and it may not necessarily be a cause for disqualifying them.
- c) In case of non-submission of the self-certification document as per format at Annexure-6, the bidder will be treated as non-responsive and their offer will be rejected.

ARTICLE 20 अनुच्छेद-20: INSTRUCTION TO THE BIDDERS बिडर हेतु अनुदेश:

1. Before submitting a bid, bidders are expected to examine the Bid Documents carefully, if they desire, may visit the work front, fully inform themselves of existing conditions and limitations including all items described in the Bid Documents. NO consideration will be granted for any alleged misunderstanding or the materials to be furnished, work to be performed or actual considerations to complete all work and comply with conditions specified in the Bid Document.
2. Any qualified deficiency, errors, discrepancies, omissions, ambiguities or conflicts in the Bid Documents, or there be any doubts as to the meaning of a provision or requirement, the same shall immediately brought to notice of GRSE Tendering Dept. in writing not less than 07 days prior to bid closing date.
3. It is understood that in receiving this bid, GRSE assumes no obligation to enter into a contract for the WORK covered by this bid request. GRSE reserves the right to reject any and all unqualified proposals or waive irregularities therein. GRSE reserves the right to evaluate each and every proposal and accept the whole or any part of the tender and the Tenderer shall be bound to perform the same at the rates quoted.
4. GRSE also reserves the right to reject any and all bids and accept the bid, which in its opinion, appears to be most advantageous to GRSE. Receipt and review of this Bid Request constitutes an agreement of confidentiality between GRSE and each of the contracting Firms preparing its Bid. GRSE reserves the right to change the form of this request to Bids, or make clarifications thereto, within a reasonable time before date of submission of Bids.

5. General Contractors assume all safety related responsibilities for the site and will furnish and maintain its own safety program for itself and its subcontractors. Contractor are bound to comply with all applicable Environmental, Health & Safety rules, regulations, policies, procedures and guidelines when performing work in the facility or site.
6. All existing applicable Laws such as ESI, PF, SERVICE, CONTRACT LABOUR, CHILD LABOUR etc. as applicable, shall be binding for the contract.

7. Independent External Monitors (IEM):

Either or both of the following Independent External Monitors will have the power to access the entire project document and examine any complaints received by him. In case of any change in IEMs, it will be informed accordingly.

The communication details of the IEMs are as follows: -

(A) Shri Bam Bahadur Singh,

Height-7; Flat No.1802, Uniworld City,

New Town, Rajarhat,

Kolkata-700160

Email: bbsinghbeml@gmail.com

(B) Shri Pidatala Sridhar, IRS (Retd.)

Flat 2C, Kanaka Lakshmi Apartments 3-6-467 & 468

Street Number-6,

Himayatnagar, Hyderabad-500029

Email: sridharpidatala@gmail.com

8. Integrity Pact (समग्रताअनुबंध):

The Integrity pact essentially envisages the agreement between prospective vendors /Bidders & buyers committing the person/officials of both the parties not to exercise any corrupt influence on any aspects of the contract. Only those vendors/bidders who enter into such an integrity pact with the buyer would be competent to participate in the bid. The format of integrity Pact is enclosed with tender documents. Refer Annexure-4. The "Integrity pact on Govt. issued bond paper of Rs. 100 duly filled as per enclosed format to be submitted in original. Bidders to ensure that every page of IP is ink signed with company seal/stamp in every pages. [Please refer guideline for IP in STAC (SI.-1) in GRSE website/ Annexure-2 of the tender]

9. Job is to be carried out as per SOTR and instruction of the Engineer in-charge.
10. Any Drawings or technical information attached / provided with this NIT is the Intellectual Property of the Company and will be governed by the specific Acts applicable thereto.
11. Post submission of Tender, such drawings and technical information are to be physically returned. Also all soft copies are to be destroyed and a self-certification to be submitted during CNC, failing which the processing of bid will not be taken further.

12. Contractors are responsible to clean up the area of work w.r.t all sort of debris generated on daily basis. If they fail to do so GRSE reserves the right to perform the cleaning activity and charge the contractor with penalty of up to 25%.
13. Bidder has to declare, in what capacity he is participating in the tender viz PSU, Limited Co, Pvt Ltd. Co., Sole Proprietorship Organization, Partnership firm, Joint Venture, etc. Supporting documents (scanned copy) confirming such status to be uploaded as attachment to Part I bid.
14. A Bidder is allowed to submit only one Bid under any capacity / status. If it is found that any one bidder under any capacity/status has submitted more than one bid, all the bids submitted by him will be rejected.
15. Difficulty in submitting the bid:

Any query/difficulty in understanding of SOR or other technical Terms may be got clarified from Mr. Tanay Saha, DGM (YM) e-mail: Saha.Tanay@grse.co.in (Contact no.7603039445) prior to submission of offer.

For difficulty in submitting / uploading of e-tender or for any system help contact person is Mr. Saraswata Palit, SR MGR (E-PROCUREMENT); e-mail/ Palit.Saraswata@grse.co.in and / or GRSE Service Provider M/s. NIC personnel may be contacted at Land line no: 033 24893902
16. E-mail Address for communication **संचार हेतू ई. मेल पता:** Vendor to provide e-mail address to enable faster communication.

ARTICLE 21 अनुच्छेद-21: e-BID INSTRUCTION ई बिड के अनुदेश:

- a) To participate in the e-Bid submission for GRSE, it is mandatory for the bidders to get their firms registered with E-Procurement portal <http://www.grse.in/etender> or <http://eprocuregrse.co.in>
- b) It is mandatory for all bidders to have class – III Digital Signature Certificate (DSC) in the name of the person who will digitally sign the bid from any of licensed Certifying Agency (CA). Bidders can see the list of licensed CAs from the link <http://www.cca.gov.in>.
- c) Bidders can view / download Part-1 (Techno-Commercial) bid documents along with all attachments. They need to fill up the downloaded documents as per instruction and upload the same during bid submission. Non-acceptance of any techno-commercial criteria is discouraged. However, if there is any, it is to be commented accordingly and also stated in the separate deviation format.
- d) Bidders need to fill up Part II (Price) bid online in HTML price bid format by inserting unit price only. No other attachment to the price bid will be reckoned.
- e) In case the bidder does not quote his rate for any item(s), it will be presumed that the bidder has included the cost of that/those item(s) in the rates of other items and the rate for such item(s) shall be considered as **Zero** and the tender will be evaluated by the Employer accordingly and the work executed by the successful bidder accordingly.

- f) Bids can be submitted only during validity of registration of bidder with GRSE e-Procurement portal.
- g) The amendments / clarifications to the bid document, if any, will be posted on E-Procurement portal / GRSE web site only.
- h) It will be the bidder's responsibility to check the status of their Bid on-line regularly after the opening of bid till award of work.
- i) **AMENDMENT OF TENDER DOCUMENT**
 - i. Before the deadline for submission of tenders, the Tender Document may be modified by GRSE Ltd. by issue of addenda/corrigendum. Issue of addenda / corrigenda will however be stopped 7 days prior to the deadline for submission of tenders as finally stipulated.
 - ii. Addendum/corrigendum, if any, will be hosted on website / e procurement portal and shall become a part of the tender document. All Tenderers are advised to see the website for addendum/ corrigendum to the tender document which may be uploaded up to 7 days prior to the deadline for submission of Tender as finally stipulated.
 - iii. To give prospective Tenderers reasonable time in which to take the addenda/ corrigenda into account in preparing their tenders, extension of the deadline for submission of tenders may be given as considered necessary by GRSE.

ARTICLE 22 अनुच्छेद-22: BID REJECTION CRITERIA बिड अस्वीकृति के मापदंड:

Following bid rejection criteria may render the bids liable for rejection:

- a) Bidder's failure to furnish sufficient or complete details for evaluation of the bids within the given period which may range in between two to three weeks depending on the deficiencies noticed in the drawings / technical data which shall not however conflict with validity period.
- b) Incomplete / misleading / ambiguous bid in the considered opinion of the Technical Negotiation Committee (TNC) of GRSE.
- c) Bid with technical requirements and/or terms not acceptable to GRSE / Customers / External agency nominated, as applicable.
- d) Bid received without qualification documents, where required as per the tender.
- e) Bid not meeting the pre-qualification parameters / criteria stipulated in the Tender Enquiry.
- f) Bid with validity expiry date shorter than that specified in the Tender Enquiry.

- g) Bid Security Declaration form not submitted as per format enclosed within time.
- h) Bidders who have not agreed for the fixed price till the validity of the tender or have quoted the variable price.
- i) Bidder not agreeing for furnishing of the required Security Deposit (SD).
- j) Bidder not submitting Integrity Pact as per requirement of the tender.
- k) Bidder submitted false/incorrect documents etc.

ARTICLE 23 अनुच्छेद-23: POST AWARD APLICABLE CLAUSES ठेका जारी करने के पश्चात लागू उपधारा:

i. Security Deposit प्रतिभूति जमा -

Non-interest-bearing security deposit of 5% of total order value is to be deposited in the manner elaborated at clause 5 of STAC. In case of non-submission of SD as per schedule, penal interest will be charged for delayed period of submission of SD beyond 15 days at the prevailing SBI cash credit rate on the amount of SD to be submitted.

ii. Work Done Certificate (W.D.C.) कार्य पूर्ति प्रमाण-पत्र (डबल्यू.डी.सी) -

The contractor will put up Work done for certification to Engineer along with all inspection report / measurement sheet signed by Quality Assurance Authority/Engineer. Work done certificate is to include whether work has been completed as per delivery schedule or the delay in days/weeks occurred in completion of work. Any recovery towards usage of GRSE resources is also to be indicated.

iii. Bill Submission बिल प्रस्तुति:

On obtaining WDC, bills are to be raised (considering the checklist for Bill Submission as per attached format at Annexure-11) by contractor monthly progressive basis. Bills are to be submitted along with supporting document (Work Done Certificate) at the Bill Receiving Counters located at the respective unit of Company. Bill is to be submitted (in 03 copies) in sealed envelope super-scribing on the envelope the Purchase Order No., Vendor code, Bill / Invoice No., Name of person /employee to whom bill is addressed, for processing. The Name of the Bill certifying authority to be mentioned on sealed envelope. Against this particular case AGM(YM) is the Bill Certifying Authority.

Note: - Transaction fee of Rs. 500.00 for first return & Rs. 1000.00 for subsequent return of bill with inappropriate documents will be charged.

iv. Payment Terms भुगतान की शर्तें:

- a. The contractor shall submit the R/A bill in triplicate along with all necessary / required supporting documents, measurement sheet etc.
- b. 90% (Ninety percent) of the value of actual work done will be paid progressively against R/A bill at a frequency of once every month during construction. The amount paid at every month shall be evaluated on the basis of actual completed works done during the previous month, against the BOQ item and unit Rates, certification of quantum and quality of work by Engineer / Engineer's Representative.
- c. Balance 10% (Ten percent) bill amount will either be retained from each bill as Performance Guarantee and the same will be released after expiry of guarantee period duly certified by the bill approving authority or be paid against submission of performance Bank guarantee.
- d. Payment will be made on actual certification basis through ECS mode.
- e. No advance payment will be made in any circumstances.

v. Liquidated Damages (निर्णीत हर्जाना)

The vendor will be liable to pay minimum Liquidated Damages @ ½ % per week or part thereof on the undelivered work subject to a maximum of 5 % of the value of the order for delayed part. The amount of L.D. may be adjusted or set-off against any sum payable to the Contractor under this or any other Contract with GRSE Ltd.

vi. Risk Purchase (जोखिम खरीद):

In case the progress of work is not satisfactory and the contractor fails to maintain the schedule, GRSE reserves the right to get the work done by alternative source at the risk and cost of sub-contractor.

GRSE shall be at liberty to purchase/obtain the service from the alternative source as it deems fit, to make good such default and or in the event of the contract being terminated, the balance of the remaining service to be delivered there under. Any excess over the job price / service rates, paid and incurred by GRSE, as the case may be, over the contract price shall be recoverable from the firm. To make good the recoverable excess amount paid, GRSE shall be at liberty to invoke Bank Guarantee and/or with other available dues of the firm.

- vii. Time of completion shall always be considered as essence of the contract / PO (कार्य समापन अवधी निविदा का मूलतत्व)** and cannot be extended for any reason whatsoever. However in an unlikely situation beyond the control of the contractor, application for extension of due time shall be submitted by the Contractor, 1 Month in advance with proper justification duly endorsed by Engineer In-charge / YM dept. of GRSE.

viii. FIRE & SAFETY PRECAUTIONS (अग्नि एवं संरक्षा सावधानियाँ):

The Vendor/Contractor shall abide by the Safety regulations/rules of the GRSE as detailed in Fire & Safety Guidelines (please refer www.grse.in). The Vendor/Contractor should take all safety precautions and provide adequate supervision & control for their workmen in order to carry out the job safely. In case of any violation of safety precaution and non-usage of safety equipment, Contractor shall be liable for a penalty which is detailed in Fire and Safety Guidelines (please refer www.grse.in). Penalty amount depends on the type and frequency of violation mentioned in the safety guideline and the same will be deducted from the defaulter's bill.

ix. MANDATORY USE OF ISI MARKED PPE BY CONTRACTOR EMPLOYEES:

The Contractor shall ensure the use of ISI marked PPE by their engaged Employees. An indicative list of ISI marked Personal Protective Equipment, is appended below for mandatory compliance by the vendors without any deviation:

LIST OF PPES

Sl. No.	Name of PPE	Standard
(a)	Safety Helmet	IS: 2925 / EN 397.
(b)	Safety Footwear	IS 15298 / EN ISO 20345
(c)	Safety Goggles	ANSI Z87.1 / EN166.
(d)	Ear Plug	IS: 9167/ EN 352
(e)	Hand Gloves	(i) IS 4770 for electrical work (ii) EN 420 for general requirement (iii) EN 388 for mechanical hazard (iv) IS:6994 / EN 407 for heat applications (gas cutting / welding).
(f)	Welding Fume Respirator & Dust mask	IS: 9473 / EN: 149
(g)	Double lanyard Safety Belt & harness, automatic fall arrestor	IS: 3521
(h)	Cotton Boiler Suit Cloth	IS: 177 - 1989 (Amended up to date), Variety 3

ARTICLE 24 अनुच्छेद-24: SUBMISSION OF BID बिड की पेशी:

1. Last date of submission of Bid / Date of opening of bid is indicated in Tender Document. Tender is liable to be rejected if all the requisite documents are not enclosed with the Part I, Techno- Commercial offer.
2. Date of opening of Part II offer i.e. Price Bid will be notified to all Techno-Commercially qualified bidders in due course after conclusion of TNC/CNC meetings and acceptance of Techno-Commercial offer. After opening of e-Price bids, the techno-commercially qualified bidders can view the System Generated Price Comparison Sheet from their own portal.
3. GRSE reserves the right to accept / reject any Tender in full or in part without assigning any reason.
4. Acceptance Format Matrix should be filled up and attached with techno-commercial bid as marks of acceptance of NIT/SOTR/STAC. In case of non-receipt of filled in STACs acceptance format matrix, it would be presumed that you have accepted all our terms& conditions as per GRSE tender until & unless deviation is specially mentioned in offer.

ARTICLE 25 अनुच्छेद-25: PRE BID MEETING बोली-पूर्व बैठक:

A pre-bid meeting with post site visit will be held on **08.07.2024** at the YM Dept., GRSE Main Unit, at 11:00 AM to discuss the detail Scope of Work of the Tender/ clarifying the queries of the bidders, if any. Vendors interested to participate in pre-bid meeting should inform Mr. Debojit Nandi, Asst. Manager (YM), email: Nandi.Debojit@grse.co.in may be contacted, 48 hours before schedule.

Anukaran J. Kandir
SR. MGR. (Contract)
Garden Reach Shipbuilders & Engineers Ltd.
GRSE Ltd., 61 Park Unit,
61, Garden Reach Road, Kolkata-700024
(Cont. no. 9163361808)

: GARDEN REACH SHIPBUILDERS & ENGINEERS LIMITED:

Kolkata-700024



**CONSTRUCTION OF REINFORCED CONCRETE HARD STAND/ PAVEMENT
WITH ASSOCIATED CIVIL WORKS AT VARIOUS LOCATIONS WITHIN RBD UNIT,
GRSE LTD, KOLKATA**

**STATEMENT OF TECHNICAL REQUIREMENTS (SOTR),
SPECIAL TERMS & CONDITIONS (STC)**

**Garden Reach Shipbuilders & Engineers Ltd
Main Yard
43/46 Garden Reach Road
Kolkata - 700024, INDIA**

GRSE Ltd. 	CONSTRUCTION OF REINFORCED CONCRETE HARD STAND / PAVEMENT WITH ASSOCIATED CIVIL WORKS AT VARIOUS LOCATIONS WITHIN RBD UNIT, GRSE LTD, KOLKATA	SOTR No. YM/4/SOTR/RBD/HS- 2(RT)/2024 Sheet: 2 of 23
Yard No.: NA Group : YM		Rev: 0
Inspection: GRSE YM Dept	Prepared by: Debojit Nandi, AM (YM) Date: 05.06.2024	Checked by: Tanay Saha, DGM(YM) Concurred by: Sanat Datta, AGM(YM)

STATEMENT OF TECHNICAL REQUIREMENT (SOTR) AND SPECIAL TERMS & CONDITIONS

CONTENTS

	<u>Page</u>
1. INTRODUCTION	4
1.1 Purpose	4
1.2 General Layout and General Arrangement Drawings	4
1.3 General Specification.....	4
2 SCOPE OF WORK.....	4
2.1 Detailed Scope of Supply & Work	4
2.2 Pre-Bid Meeting.....	6
2.3 Submission of Technical Documents along with the Bid	6
2.4 Drawings, Design Calculations and Documents including Quality Assurance Plan (QAP)	6
2.5 Other General Requirements	7
2.6 Detail Job Quantity	8
3 TECHNICAL SPECIFICATIONS.....	8
3.2 Approved Make / Brand	10
3.3 List of BOQ Items	11
4 HEALTH AND SAFETY	11
4.1 Safety Guidelines to be adopted by the Contractors at GRSE Premises	11
4.2 Health & Safety Plan.....	14
4.3 Health & Safety Risk Assessment.....	15
4.4 Health & Safety Management Plan	15
4.5 Height work	15
5 OTHER REQUIREMENTS	16
5.1 Contractor to Supply all Materials.....	16
5.2 Deployment of Resources.....	16
5.3 Testing of Materials and Acceptance.....	16
5.4 Inspection by the Engineer.....	16
5.5 Quality & Workmanship	17
5.6 Materials / Work not acceptable to Engineer	17
5.7 Contractor to Commence Work	17
5.8 Supervision by the Contractor.....	17

5.9	Setting Out	18
5.10	Care of the Work	18
5.11	Protection of the Existing Structures / Machines.....	18
5.12	Existing Roads & Shop floor to be kept clean.....	18
5.13	Control of Pollution / Health Hazards.....	18
5.14	Site-In charge / Log Book / Hindrance & other Records.....	18
5.15	Clearance of Site	19
6	GRSE SCOPE.....	19
6.1	Electricity.....	19
6.2	Water	19
7	SPECIAL TERMS AND CONDITIONS OF CONTRACT.....	20
7.1	Technical Eligibility Criteria.....	20
7.2	Site Condition.....	20
7.3	Award of Works	21
7.4	Site Consultations.....	21
7.5	Work Done Certificate (W.D.C.)	21
7.6	Completion Period.....	21
7.7	Guarantee Period / Defect Liability Period (DLP).....	21
7.8	Submission of RA Bills by the Contractor	21
7.9	Ownership of Scrap.....	22
7.10	Completion Certificate.....	22
7.11	Variation and its Valuation	22

1. INTRODUCTION

1.1 Purpose

1.1.1 Garden Reach Shipbuilders and Engineers Limited (GRSE), Kolkata invites tender for Construction of Reinforced Concrete Pavement / Hardstand (Area approx.14550 Sqm) along with associated civil works at various locations within RBD Unit, GRSE Kolkata as per Item-Rate contract basis.

1.2 General Layout and General Arrangement Drawings

1.2.1 General Layout drawing of the above concrete hardstand / pavement is enclosed along with the tender (**List at Appendix-1**) for ready reference.

1.3 General Specification

1.3.1 This set of technical requirement provides a general guideline for successful execution of the work under the scope of this tender. The work for Construction of Reinforced Concrete Hardstand / Pavement is required to be carried out in accordance with the following scope of work, performance specification, Bill of Quantities (BOQ), relevant Indian Standard Codes for design & construction, Specification as per the latest PWD/CPWD Schedule and best engineering practices.

1.3.2 The contractor shall have design-engg. setup for carrying out detail design & drawing of concrete pavement & Civil structure as per the requirement of job under this tender.

2 SCOPE OF WORK

2.1 Detailed Scope of Supply & Work

2.1.1 The work primarily involves construction of reinforced Concrete Hardstand / Pavement of GRSE RBD Unit as indicated in the layout drawing (**Appendix-1**) enclosed along with the tender. The Scope of work under this tender broadly comprises of following: -

- a) Physical site survey by using Total Station / Auto level based on job requirements and necessities of GRSE for finalisation of GA drawing.
- b) Preparation of Design and Drawing including construction drawing of the above pavement [by qualified (minimum BE) & experienced Design Engineer] for approval by GRSE.
- c) GA and detail construction drawing shall be prepared taken into consideration of GRSE requirement.
- d) Design and construction of Hard stand shall be in accordance with BIS 456, other relevant BIS, IRC, MoRTH & PWD specification as applicable.
- e) Hard stand naming H.S-3 & H.S-5 as indicated in the layout drawing (**Appendix-1**) shall be designed for 350 Ton crawler crane.
- f) Excavation of soil / bituminous road as per requirement. While excavating the earth / bituminous surface it is desirable to scan the area with proper scanning machine for presence of any

underground electrical cable, water and fire pipeline. Any damages caused are to be repaired without any extra cost.

- g) Dressing/levelling / filling and compacting original ground by suitable roller of capacity 80KN to 100 KN to obtain the desired dry density and subsequently conducting Proctor compaction test as per the direction of EIC.
- h) Dismantling of RCC/PCC/Masonry.
- i) Use of water proof steel shuttering.
- j) Concreting (M30 Grade) for reinforced cement concrete hardstand with necessary expansion and contraction joint along with the use of dowel bar. **Appendix-2** showing the typical concrete joint is enclosed along with the tender.
- k) Laying of M30 grade steel fibre reinforced concrete.
- l) Use of vacuum dewatering pump is recommended while casting of concrete.
- m) Maintaining proper slope/gradient while constructing the pavement, so that no water stagnation take place. Concrete pavement/hardstand shall have broom finish on the top surface and shall maintain uniform straightness along the edge.
- n) The above proposal also includes the construction of drains, Laying of HDPE pipe conforming to IS 16098(Part-II/2013) and service line trench as per requirement .
- o) Masonry work.
- p) Pavement marking work.
- q) Fabrication and erection of steel material (If Structural Steel Section or Hollow Section is supplied by GRSE, rate of recovery @ Rs 43140/ ton as an issue rate from Bill).
- r) All equipment and machinery including consumables necessary for the construction, fabrication & erection are to be arranged by the contractor.
- s) Pumping out of water if required during work.
- t) Cutting and trimming of trees as required.
- u) Relocation of trees without damaging the roots, to the new position as decided EIC with in GRSE RBD Unit.
- v) Taking out all unsalvageable, discarded material/items, all debris/waste as generated during dismantling work and also misc. loose items lying inside the building out of GRSE premises (as per prevailing rules of GRSE) progressively and segregating & shifting the salvageable materials (metal and wood) within the GRSE premises in the designated area.
- w) Timely disposal of debris in environmentally sound manner abiding by prevailing Municipal Solid Wastes Rules of Municipal Corporation & get appropriate clearance from the local authority as applicable.
- x) Any other related Civil works for successful completion of the project.
- y) Site Clearance

- z) Defect Liability of 12 (twelve) months against defective material, workmanship, quality for material supplied for the executed work.

2.2 Pre-Bid Meeting

2.2.1 Attending pre-bid meeting along with site visit is mandatory and the submitted Bid will not be considered in case of non-participation. Pre-bid Meeting will be held on 10th day from the date of publication of tender.

2.2.2 It is always advisable to attend **Pre-bid meeting and site visit physically**. If for any reason physical attendance is not possible, **pre-bid meeting can be attended via video conference and site visit can be attended through video call** and in that case prior intimation has to be given at least one day before Pre-bid meeting.

2.2.3 Prospective Tenderers shall submit their queries, if any in connection with the Tender, in writing by email at the earliest to enable GRSE to clarify the same. The last date of submitting the queries is 2 days prior to the pre-bid meeting. Copies of the Employer's response will be displayed on GRSE website www.grse.in including a description of the enquiry but without identifying its source.

2.2.4 Also, the Bidder before submission of tender shall make a detail site visit for proper assessment of the work. The tendered job being item-rate contract as per the BoQ, the Bidder should assess and bring out their observation (if any) during pre-bid meeting for discussion.

2.3 Submission of Technical Documents along with the Bid

2.3.1 The Tenderer shall submit following documents along with their technical Bid;

2.3.1.1 Organisation Chart

2.3.1.2 Work Plan i.e. Methodology

2.3.1.3 Schedule/Programme of work with milestones

2.3.1.4 Necessary supporting documents for work experience as per technical eligibility criteria.

2.3.1.5 Initial QAP

2.3.1.6 Initial Safety Plan

2.4 Drawings, Design Calculations and Documents including Quality Assurance Plan (QAP)

2.4.1 The Contractor shall submit GA, Drawings, Design Documents including QAP etc. to GRSE for review/approval.

- a) Finalisation of GA, detailed design & construction working drawings for pavement are required to be submitted by 10 days from the date of LOA. The contractor shall ensure that each drawing & document contain all necessary details to reduce number of revisions.

- b) An Outline Quality Assurance Plan covering activity including procurement, fabrication, erection, testing critical inspection stages and verification/certification shall be submitted at the time of submitting the Technical Bid. The Contractor shall ensure that his detailed Quality Assurance Plan is prepared and submitted (10 days from the receipt of LOA) prior to the Commencement of the Works for approval. The Contractor has to comply with the quality requirements as per the relevant BIS. All relevant Test Reports / Manufacturing Certificates as per the approved QAP shall be submitted. Approval of document shall not relieve the Contractor of any of his obligations under the Contract.
- c) Work programme with break-up of activities shall be submitted along with the Technical Bid. A detailed network programme (preferably in MS project) showing the activities, milestones, critical path etc shall be submitted by 10 days from LOA.
- d) Monthly Progress Reports
- e) As built drawings (GA, section, elevation etc.) of Concrete reinforced Pavement, including allied facilities in both hard and soft (AUTOCAD & Pdf) format on completion of work.

2.5 Other General Requirements

2.5.1 The Contractor shall carry out detail survey on site for finalisation of extent of work.

2.5.2 The Contractor will be responsible for overall site management and coordination of site activities within the boundary of the works, as necessary to ensure the adequacy, stability and safety of the works and of persons at the site. The contractor shall require planning his work in coordination with on-going production activities of GRSE, other contractors working in and around the workplace.

2.5.3 The contractor shall abide by prevailing rules & regulations for entry of their workmen, supervisor etc., working inside GRSE premises including working in extended hours/holidays and also entry/exit of construction equipment, materials & consumables.

2.5.4 No contractor workmen are allowed to enter into GRSE premises after 08:30 AM and allowed to exit before the scheduled-out time i.e. 05:06 PM on week days and 01:00 PM on working Saturdays. Early exit is possible on approval from Engineer-In charge.

2.5.5 The contractor shall adopt all precautionary safety measures adhering to prevailing safety rules & regulations & in consultation with GRSE Safety Dept. while working at height (roof/girder/louwer etc.) during dismantling, structural welding/repair, erection, installation of sheet, painting etc. Since the work is primarily at height using safety net, safety belt, roof ladder, fall back arrester etc as per BIS is mandatory. The contractor shall take all necessary work permit from concern Departments of GRSE (i.e. Safety, Fire etc.) as applicable in line with prevailing rules in GRSE. (Refer Clause No -4 Health and Safety of this SOTR for detail safety requirement).

2.5.6 The submission to and comment/acceptance by the Engineer of such programmes, methods, drawings, designs, QAP shall not relieve the Contractor of any of his duties or responsibilities under the Contract.

2.5.7 Dismantling work, handling & removal of salvageable & unsalvageable materials shall not come in the way of ongoing functioning of GRSE.

2.6 Detail Job Quantity

2.6.1 BOQ with item quantities for construction as part of SOTR are given in the tender is tentative. The quantities set out in the BOQ of the tender shall be treated as estimated quantities of the work and shall not be deemed as actual or correct quantities of the work to be executed by the Contractor.

2.6.2 The Contractor shall execute required quantity for successful completion of project work at the same contractual rates and terms & conditions for any extent of variation in stipulated BOQ quantities.

2.6.3 List of BOQ Items considered under the scope of this tender is provided at successive clause for reference.

2.6.4 All bidders shall quote against all the items of BOQs, otherwise, their bid would be considered as Incomplete Bid and shall be liable for rejection.

3 TECHNICAL SPECIFICATIONS

3.1.1 Structural Steel Work

3.1.1.1 In case the material is procured by the Contractor, the Contractor shall submit the test certificate conforming to appropriate standards of all steel materials used for fabrication. All structure steel shall be free from rust, scales, lamination, cracks, fissures and other surface defects.

3.1.1.2 Steel used for construction exposed to weather or other corrosive influences shall not be less than 8 mm in thickness and in construction not exposed to weather, thickness shall not be less than 6 mm. The controlling thickness as specified above, for rolled beams and channels shall be taken as the mean thickness of flange, regardless of web thickness

3.1.1.3 Sealed tubes and sealed hollow box sections used for external construction exposed to weather shall not be thinner than 4 mm and for construction not exposed to weather shall not be thinner than 3 mm.

3.1.1.4 All fabrication of structural steelwork shall be in accordance with IS: 800 and as per the approved drawings unless otherwise specified. The tolerances of fabrication of steel structures shall be in accordance with IS: 7215 unless otherwise specified.

3.1.2 Concreting Work (Nominal & Ready Mixed Concrete):

3.1.2.1 The Contractor shall provide ready mixed concrete (RMC) including all labour, materials, equipment and incidentals required for proper execution and completion of all concrete work as specified in IS 456(Latest edition) and latest PWD schedule, West Bengal.

3.1.2.2 The Contractor shall not pour any concrete unless and until the representatives of the Engineer have inspected the formwork, reinforcing steel and inserts and sleeves if any and given permission to place concrete.

3.1.2.3 The grade of RMC is M 30.

3.1.2.4 The contractor shall use concrete vibrator machine while casting of concrete.

- 3.1.2.5 Where nominal concrete mixes are described as 1:1:2, 1:1.5:3 etc. The figures denote the relative proportions of cement, dry sand and graded stone aggregate respectively.
- 3.1.2.6 Portland Pozzolana Cement (Grade-53) conforming to IS: 1489 (Part-I) (Fly ash based) to be used.
- 3.1.2.7 Shuttering shall be steel shuttering at all locations for all shapes etc in all complete including de-shuttering of the same after specified period without damaging the concrete works as directed by Engineer-in charge, etc. Providing and applying approved form oil on all surfaces of formwork coming in contact with concrete as per specifications and drawings and as directed by Engineer in-charge. Shuttering shall be of leakproof.
- 3.1.2.8 Each layer of concrete shall be compacted fully before the succeeding layer is placed.
- 3.1.2.9 All concrete work shall be water cured for a minimum period of 7 days after concreting or as directed by Engineer.

3.1.3 Steel Fibre Reinforced Concrete

- 3.1.3.1 The Contractor shall provide ready mixed steel fibre reinforced concrete (RMC) including all labour, materials, equipment and incidentals required for proper execution and completion of all concrete work and latest PWD schedule, West Bengal.
- 3.1.3.2 Steel fibre shall be continuously deformed undulating with aspect ratio between 0.45 to 01mm and length between 12.5 to 60mm manufactured from cold drawn wire and having a maximum tensile strength 1200N/sq.mm.

3.1.4 Steel Reinforcement

- 3.1.4.1 Supplying TOR steel reinforcement (of approved manufacturer) of tested quality of any diameter up to 32mm dia minimum Fe 415 conforming to IS:1786 for reinforced concrete work in all sorts of structures at all depth and height including distribution bars, stirrups, binders etc. initial straightening and removal of loose rust (if necessary), cutting to requisite length, hooking and bending to correct shape, placing in proper position and binding with 16 gauge black annealed wire at every intersection, complete as per drawing and direction.

3.1.5 Masonry / Brickwork

- 3.1.5.1 The bricks shall be locally available kiln burnt bricks of generally regular and uniform size, shape & colour, uniformly well burn but not over burnt.
- 3.1.5.2 The size of brick shall normally 230 mm x 115 mm x 75 mm. Bricks of one standard size shall be used on one work unless specially permitted by the Engineer.
- 3.1.5.3 After immersion in water, absorption by weight shall not be exceeding 20% of dry weight of the brick when tested according to IS 1077 of latest edition. Unless otherwise specified the load to crush the brick when tested according to IS 1077 of latest edition shall not be less than 75 Kg/Sq.cm.
- 3.1.5.4 Prior approval of Engineer shall be obtained for the brands of bricks to be used in the work after compliance with the above specifications/tests.
- 3.1.5.5 Unless otherwise specified, mortar for brick work shall be composed of 1:4 ratio i.e. 1 part of cement to 4 parts of sand.

3.1.6 Painting Work

- 3.1.6.1 The Exterior and Interior Painting on all types of surface in accordance with the 'drawings' and Schedule of finishes or as per the guideline explained in IS: 1477, IS: 2395 and as per direction of the Engineer and 'Schedule of Quantities'.
- 3.1.6.2 All surfaces for painting shall be properly sand papered and cleaned by mechanical buffing and where necessary good quality putty shall be used to hide all holes, cracks, open joints etc. The rate for painting includes such work.
- 3.1.6.3 Paint shall be applied with approved brushes and surfaces shall be sand papered after every coat. All work when completed shall present a smooth, clean solid and uniform surface, to the satisfaction of the Engineer-in- Charge.
- 3.1.6.4 All surfaces for painting, if they are new, should have a coat of suitable primer before application of the paint. Old surfaces where existing paints have been completely worn out owing to long use should also receive a coat of priming before application of fresh painting.
- 3.1.6.5 **Steel Primer:** For steel surface red oxide primer, zinc chromate primer of approved brand and manufacture and as per direction of the Engineer-in-Charge is to be applied on the surface.
- 3.1.6.6 **Acrylic Primer Coat (solvent based Primer):** Acrylic primer coat is to be used as base coat on wall finish of cement, lime or lime cement plaster surface before application of any wall coating e.g. distemper, oil-based paints, synthetic enamel, acrylic emulsion etc. on them.
- 3.1.6.7 **Enamel Paint:** Enamel paint of approved brand and manufacture shall be used. Each coat shall be allowed to dry for 24 hours and lightly rubbed down with fine grade sand paper and dusted before the next coat is applied. The finished surface shall present an even and uniform appearance. Minimum thickness of paint should be 25µm/coat.
- 3.1.6.8 **Acrylic Emulsion Paint:** Acrylic emulsion paint are not suitable for application on external surface and surface which are liable to heavy condensation and are be used generally on internal surface. For plastered surfaces a cement priming coat is required before application of acrylic emulsion. Acrylic emulsion paint of approved brand and manufacture and of the required shade shall be used.
- 3.1.6.9 **Epoxy Paint:** The painting scheme include surface preparation to SA2 1/2 by blasting,1st coat of inorganic zinc silicate primer of 65-micron, intermediate coat of epoxy high build MIO of 100 micron and two finish coats of high build epoxy of 2 x 100 micron.

3.2 Approved Make / Brand

Item	Make / Brand
Cement	Lafarge / ACC / Ultratech or equivalent as approved by Engineer
RMC	Lafarge / ACC / Ultratech or equivalent as approved by Engineer
Reinforcement Steel	TISCO / SAIL / ESSAR / RINL/ SRMB or equivalent as approved by Engineer.

Structural Steel	SAIL / TATA / JINDAL / equivalent as approved by Engineer
Paint	Asian Paints / Berger / ICI / Nerolac or equivalent as approved by Engineer
GI Pipe	Tata/Jindal
HDPE Pipes	Supreme/Oriplast/Skipper/Astral or equivalent as approved by Engineer

3.3 List of BOQ Items

List of BOQ items considered under the scope of this tender. However, tenderer may point out any discrepancy or inclusion of any new BOQ item in the Pre-bid queries. BOQ is attached in Appendix-3

4 HEALTH AND SAFETY

4.1 Safety Guidelines to be adopted by the Contractors at GRSE Premises

- 4.1.1** The contractor shall provide & ensure use of ISI marked Industrial Safety Shoes, Safety Helmets, Retractable type Full Body Harness (Double Lanyard), Welding Fume Respirator, Safety Goggles, Hand Gloves, Boiler Suits & other necessary Personal Protective Equipment (PPEs) depending upon the nature of job while at work.

LIST OF PERSONAL PROTECTIVE EQUIPMENT (PPE)

SL. NO.	NAME OF PPE	STANDARD
1	Safety Helmet	IS : 2925/EN : 397
2	Safety Footwear	IS : 15298/EN : ISO 20345
3	Safety Goggles	ANSI: 287.1 / EN: 166
4	Ear Plug	IS: 9167 / EN: 352
5	Hand Gloves	i. IS: 4770 for Electrical work. ii. EN: 420 for general requirement. iii. EN: 388 for Medical Hazard. iv. IS: 6994 / EN: 407 for heat applications (Gas Cutting / Welding)
6	Welding Fume Respirators & Dust Mask	IS: 9473 / EN: 149
7	Double lanyard Safety Belt & harness, automatic fall arrestor.	IS: 3521
8	Cotton Boiler Suit Cloth	IS: 177-1989 (Amended up to date), Variety 3

4.1.2 Hot Work Safety (Gas Cutting, Welding etc.):

Prior to commencement of hot work, surrounding areas (including other side of the bulkhead & deck) shall be inspected for the presence of any inflammable materials and no Hot Work shall be carried out without obtaining Hot Work Permit from Fire Fighting Department of GRSE

- (i) Adequate ventilation must be arranged while working in confined spaces throughout the period of carrying hot work.
- (ii) Damaged gas hoses & welding cables should not be used for gas cutting & welding job. Gas cutting hoses & copper welding cables must be ISI marked of reputed make. Use of Aluminium Welding Cable is prohibited during construction activities from fire safety point of view.
- (iii) The gas cutting hose should be separated from welding cables & electric cables.
- (iv) The welding holders, if energized, should not be left unattended.
- (v) All gas cutting torches shall be ISI marked of reputed make and must be fitted with standardized FLASH BACK ARRESTER.
- (vi) Full insulated welding holders (ISI marked) shall be used in construction jobs.
- (vii) During recess period (Lunch time and at the end of day's work) or when work is suspended for more than half an hour, the gas cutting hoses shall be disconnected from the cylinder valves and removed from ship's confined space and keep the same in an open area / Main Deck.
- (viii) All gas equipment shall be subjected to "Water Dip" test daily, before taking those on board. A record of the testing to be maintained by the person carrying out such test.
- (ix) Electric power shall be cut off from welding transformer end during recess period, at the end of day's work and whenever the work is stopped for at least half an hour.
- (x) During hot work activity at the overhead location and on the bulk head, a person must be deputed at the opposite side of hot work from fire safety point of view. xii. Use of LPG for gas cutting is strictly prohibited in the shipyard.

4.1.3 Safety during Grinding:

- (i) All grinding machines shall be provided with standardized & non-expired grinding wheels of reputed make and shall be fitted with protective metal guards during grinding job.
- (ii) Use of oversize grinding wheel is prohibited.
- (iii) All grinding wheels shall be of reputed brand & make and shall be stored / handled carefully prior to taking into use.
- (iv) Damaged grinding wheel shall be replaced forthwith for avoiding likely hood bursting of the Wheel.
- (v) Suitable Safety Goggles / Transparent Face Shield to be used for protection of eyes against foreign body.
- (vi) Double insulated type portable Grinding Machines to be used.

4.1.4 Safety precautions while working at height:

- (i) Prior to starting of any work at height from where a person may fall and get injured, "Height Work Permit" (Annexure - I) shall be issued by the concerned official of YM Department to the concerned contractor firm and to be forwarded to Safety Department for clearance.

- (ii) The vendor representative / Supervisor shall check the height work area before commencement of height work & confirm to comply according to the checklist (as per Annexure – II).
- (iii) All temporary scaffolding structure (Metal / Bamboo) should be erected with adequate stability of the structure and dimensions as per IS: 3969 (Part -
- (iv) While erecting the scaffolding structure and working on scaffolding platform, all concerned personnel shall wear full body harness with double Lanyard (safety belt) with anchoring the lifeline to the nearest rigid structure.
- (v) The scaffold platforms to be provided with suitable hard barricading at the open sides. Top guard must be at least 42", mid 21", toe board 4" from the working surface and wooden working platform / planks to be secured at both ends for preventing over turning of the wooden planks.
- (vi) The staging / scaffolding planks should be so arranged that there is no gap between them.
- (vii) There should be sufficient lighting in and around the staging / Scaffolding, if the work is planned after the sunset.
- (viii) Defective wooden planks (weak, rotten, cracked, split, bent) should never be used on staging. Staging planks to be checked thoroughly and defective planks should be replaced prior start of work.
- (ix) While erecting scaffold, care should be taken to ensure that the distance between two transoms is not more than one metre.
- (x) Suitable Ladders should be tied / anchored at the top as well at the bottom to prevent dislodging from it's position.
- (xi) Where erection of scaffolding structure is not feasible / provided, appropriate type of Suspended Working Platform for single person in sitting posture (Boatswain's Chair) may be used by anchoring on to the fixed rigid structure in conjunction with use of double lanyard full body harness (safety belt) and automatic fall arrestor to prevent inadvertent fall of person from height.
- (xii) As per requirement, Safety Net (having suitable mesh size) to be erected just below the work location to prevent fall of man, material and tools & tackles from height.
- (xiii) 'Safety Tool Box' to be conducted by the Site In-charge / Supervisor of the contractor firm on regular basis prior to commencement of day's work and a register to be maintained at site with signature of the height workers, duly endorsed by the Site In charge of the firm.

4.1.5 Safety precautions while working on fragile roof (A.C Sheet):

- (i) Prior to starting of any job on fragile roof (A.C.Sheet), "Height Work Permit" (Annexure - I) shall be issued by the concerned official of Civil Department to the contractor firm and to be forwarded to Safety Department for clearance.
- (ii) The vendor representative / supervisor shall check the height work area before commencement of height work & confirm to comply according to the checklist (as per Annexure – II).
- (iii) While working on fragile roof (A.C.Sheet), dedicated Roof Ladder along with the full body harness with double lanyard (safety belt) shall be used on the top of the roof and safety belt to be anchored to a rigid structure above the roof.
- (iv) Safety Net (having suitable mesh size) to be erected just below the work location to prevent fall of man, material and tools & tackles from height.

- (v) Where a rigid structure is not available for anchoring the hook of safety belt (double lanyard full body harness), a dedicated horizontal life line of adequate strength to be erected above the roof for ensuring safe movement across / along the fragile roof.
- (vi) The underneath area of work on fragile roof shall be cordoned with cautionary tape with a minimum site clearance of 5 mtr. in all direction from the location of work and sufficient number of Cautionary Notice Board (in Bengali & Hindi Language) to be displayed & maintained at site for general information to the others / personnel working in the close vicinity.
- (vii) 'Safety Tool Box' to be conducted by the Site In-charge / Supervisor of the contractor firm on regular basis prior to commencement day's work and a register to be maintained at site with signature of the height workers, duly endorsed by the Site In charge of the firm.
- (viii) All personnel working on fragile roof, shall be well trained and conversant with the use of Roof Ladders, full body harness safety belt, anchorage of lanyard of harness on the horizontal lifeline etc.

4.1.6 Safety precautions during & after excavation of soil:

- (i) Civil maintenance work which requires excavation of soil, shall be cordoned immediately with hard fencing of adequate strength, all around the excavated location, to prevent inadvertent fall of persons inside the trench.
- (ii) Such cordoned areas are also to be marked / identified with cautionary banners / danger tapes to attract attention of the moving vehicles inside the factory premises.
- (iii) After filling up of excavated locations, the said area should not be immediately left opened / allowed for vehicle movement until the total area is suitably settled & made strengthened to avoid any vehicle to be entrapped therein.

4.1.7 Electrical Safety:

- (i) Only standardized electrical extension boards fitted with industrial type plug, socket and MCB, to be used at site for drawing temporary power from the nearby electrical outlet points.
- (ii) Use of damaged / worn out power cable, electrical extension boards, plug & sockets etc. are strictly prohibited at work site.
- (iii) Electrically operated power tools (e.g. Cutting Wheel, Grinding Machines, Hand Held Concrete Vibrator etc.) shall be of double insulated type.
- (iv) Contractor personnel of the firm shall not tamper / alter any electrical connection for exigency of work. For all type of required electrical support, GRSE electrical department shall be approached through proper channel.

4.2 Health & Safety Plan

4.2.1 In addition to the GRSE's Health and Safety Guideline the Contractor must fully comply with all relevant Indian Health and Safety legislation. Nothing in the contract or this specification shall reduce his statutory obligations with respect to health and safety.

4.2.2 The Contractor shall be responsible for ensuring that his works are safe. To this end, contractor shall nominate a suitably qualified Health and Safety Manager who shall prepare a Health & Safety Plan for the works in accordance with GRSE guidelines/standards. The Contractor shall be responsible for implementing the Health & Safety Plan with respect to his works. The Health

& Safety Plan shall, as a minimum, contain a Health & Safety Risk Assessment and a Health & Safety Management Plan.

4.3 Health & Safety Risk Assessment

4.3.1 This shall identify all potential hazards to people that may arise due to the works. In this context "people" shall include anyone who may be affected by the works whether Contractor's personnel, Owner's personnel, other contractors' personnel, visitors, general public etc.

4.3.2 Hazards shall include those which may arise due to the interaction of the Contractor's own activities with those of others in the Main Yard including dockyard operations.

4.3.3 The risk assessment shall identify appropriate methods to eliminate or reduce the risk of the hazard occurring to the minimum that is reasonably practicable.

4.3.4 It shall define the specific ways in which each Hazard and its consequent Risk is to be minimised, for example by:

- a) Training of personnel.
- b) Physical measures on site e.g. temporary works, barriers etc.
- c) Methods of work on site.
- d) Management e.g. permits to work; monitoring and control of potentially hazardous activities, co-ordination with other parties
- e) Documentation e.g. method statements, maintenance manuals etc.

4.4 Health & Safety Management Plan

4.4.1 This shall document the Contractor's plan for managing, co-ordinating, implementing, monitoring and controlling his activities with respect to Health & Safety.

4.4.2 It shall include an organisation chart which shall identify those personnel in the Contractor's organisation (office and site) who have particular responsibilities for Health & Safety matters, with their contact details.

4.4.3 The Contractor's Health & Safety Manager or his nominated representative shall be available at all times during the progress of the works.

4.4.4 It shall include but not be limited to:

- a) Methods for assuring health and safety, both of his own personnel and that of other people in the shipyard who may be affected by the Contractor's activities.
- b) Staff training and certification.
- c) Accident reporting.
- d) Reporting of non-compliance.
- e) Safety Management and control of Sub-Contractors.
- f) Work Equipment, Plant, and Personal Protective Equipment.
- g) First aid provision.
- h) Emergency procedures.

4.5 Height work

4.5.1 All height work shall be carried out adopting appropriate safety measures like erecting steel / iron scaffolding, use of cherry picker / man lift or any other suitable safe measure to carry out such jobs on obtaining proper height work permit from GRSE safety department. Safety belt, fall arrestor, PPE etc shall be used during any height work execution. GRSE safety norm shall be followed while work execution in side of the factory premises. Under no circumstance, safety shall be compromised.

5 OTHER REQUIREMENTS

5.1 Contractor to Supply all Materials

5.1.1 Unless stipulated otherwise in the Contract, all materials including consumables required for the work shall be procured and supplied by the Contractor with the approval of the Engineer or his Representative and subject to subsequent testing as may be required by the Engineer or his Representative.

5.1.2 The Contractor shall comply with the relevant IS Codes.

5.2 Deployment of Resources

5.2.1 Contractor shall provide adequate number of qualified / experienced workmen, with experienced Engineers / Supervisors & also one experienced / qualified Safety Officer having requisite qualification in Industrial Safety, recognized by the State Govt. / AICTE and working experience in industry / project work. The credentials of the vendor's safety personnel are to be submitted to Unit Safety Department duly endorsed by the concerned stakeholders mentioning the relevant P.O. No. and also have sufficient construction equipment, materials, tools & tackles etc. for achieving the schedule target as per approved work schedule. The contractor shall ensure timely deployment of all above resources at site to ensure contractual completion.

5.2.2 The contractor shall ensure deployment of adequate and proper skilled /semi-skilled workforce as per work requirements and optimum supporting unskilled workforce as necessary.

5.3 Testing of Materials and Acceptance

5.3.1 Test samples shall be prepared and submitted for approval of the Engineer or his Representative, whenever required to do so, all at the Contractor's cost.

5.3.2 The Contractor shall submit valid correlated test certificates conforming to applicable standards for materials/items before incorporation in the permanent works.

5.3.3 Testing of materials shall be conducted as per the approved Quality Assurance Plan or relevant Indian Standards.

5.3.4 Unless stipulated otherwise in the Contract, the cost of any test required by the Engineer or his representative in respect of materials and workmanship deployed on the work shall be borne by the Contractor.

5.4 Inspection by the Engineer

5.4.1 For Site inspection, the Contractor shall give adequate notice to the Engineer (authorised representative of GRSE).

5.4.2 The Contractor shall provide the Engineer with proper free and safe access to the Contractor's works and stores or his sub-contractor's works and stores at all times and shall provide reasonable facilities to enable him to undertake his inspection.

5.4.3 The Contractor shall make all necessary arrangements to enable stage inspections by the Engineer.

5.4.4 The Engineer or his Representative shall have power to certify or disapprove/reject works or materials, in accordance with the Conditions of Contract.

5.5 Quality & Workmanship

5.5.1 Quality and workmanship of all items/materials and work shall conform to BOQ /Technical Specification / relevant Indian Standards. The Contractor shall be responsible for any loss/damage during the course of work to any structure, machinery, equipment, fittings, wiring, piping, and systems etc. caused by his workman (or his sub contractor's) and the Contractors shall make good such damage free of cost.

5.6 Materials / Work not acceptable to Engineer

5.6.1 The Engineer or his Representative shall have the power to inspect any material and work at any time and to order at any time – (a) for removal from the Site of any material which in his opinion is not in accordance with the Contract or the instruction of the Engineer or his Representative, (b) for the substitution by the proper and suitable materials, or (c) the removal and proper re-execution of any work, which in respect of material and workmanship is not in accordance with the Contract or the instructions of the Engineer. The Contractor shall comply with such order at his own expense and within the time specified in the order. If the Contractor fails to comply, the Engineer shall be at liberty to dispose any such materials and re-do any work in the manner convenient to the Engineer by engaging any outside agency at the risk and expense of the Contractor and after giving him a prior written notice of 7 (seven) days. The Contractor shall extend his full assistance as required by the Engineer during inspection.

5.7 Contractor to Commence Work

5.7.1 The Contractor shall mobilize and commence the work on site within 15 days from issue of LOA/PO whichever is earlier. The Contractor shall then proceed with the work with due expedition and without delay, except as may be expressly sanctioned or ordered by the Engineer or his Representative, time being deemed the essence of the Contract on the part of the Contractor.

5.8 Supervision by the Contractor

5.8.1 The Contractor shall engage experienced and qualified Engineers at site in day-to-day charge of the work and the Engineer should be authorized to receive instructions from the Engineer-In charge /GRSE. He shall receive orders given by the Engineer from time to time and shall act on them promptly. One fully responsible and experienced & Qualified Site-in-charge (Minimum Qualification: Diploma with 5 years' experience) has to be posted at the site during progress of work.

5.8.2 The Contractor shall provide necessary and adequate supervision during the execution of the works and as long thereafter as the Engineer or his Representative shall consider necessary during the Defect Liability Period.

5.8.3 The Contractor or his competent and authorised agent or representative shall be constantly at site during working hours. The Contractor shall inform the Engineer or his Representative in writing about such representative / agent of him at site. Replacement of any of the authorised agent of the Contractor during the currency of Contract shall only be with prior written approval of the GRSE/ Engineer.

5.8.4 The Contractor and his authorised agent or representative shall be readily available to meet with the GRSE and/or Engineer and/or Engineer's Representative and instructions given to him by the Engineer or his Representative in writing shall be binding upon the Contractor.

5.9 Setting Out

- 5.9.1** The Contractor shall be responsible for the true and proper fitting / alignment of the Works in relation to reference points / lines / levels as applicable. The checking of any alignment or level by the Engineer or his Representative shall not in any way relieve the Contractor of his responsibility for the correctness thereof and he shall fully provide, protect and preserve the setting out of the works.
- 5.9.2** The Contractor shall promptly notify the Engineer of any discrepancy in the setting out of the works.

5.10 Care of the Work

- 5.10.1** From the commencement of the works till issue of the Completion Certificate hereof; the Contractor shall take full responsibility for the care thereof. Save for the excepted risks, any damage, loss or injury to the work or any part thereof shall be made good by the Contractor at his own cost as per instruction and to the satisfaction of the Engineer, failing which the Engineer or his Representative may cause the same to be made good by any other agency and the expenses incurred and certified by the Engineer / Owner, shall be recovered from the Contractor.

5.11 Protection of the Existing Structures / Machines

- 5.11.1** The Contractor will be responsible for the protection of all existing structures, machines, cranes, electrical installations, ship blocks, surrounding roads, pavements, drains etc. adjacent to and within the Works from any type of damage.
- 5.11.2** Before the commencement of work, the Contractor to take necessary precautions and measures to safeguard the existing structures/machines/materials/various installations/roads etc. and protect them from possible damages. For that the Contractor will arrange adequate safety nets, ropes, tarpaulin sheet, scaffolding, rubber mats etc. without any extra cost.
- 5.11.3** If any damage occurs by the Contractor or sub-contractor or contractor's workmen, will be recovered suitably from the Contractor.

5.12 Existing Roads & Shop floor to be kept clean

- 5.12.1** Existing roads & Shop floor used by vehicles/machineries of the Contractor or any of his subcontractors for supplies of materials or plant shall be kept clean and clear of all dirt, mud or any other materials dropped by the said vehicles or their tyres. The Contractor shall provide and maintain all equipment as may be necessary to keep the Owner's roads clean as required by this Clause.
- 5.12.2** Any damage caused by the Contractor to the surface of the roads or car parks shall be made good at his own cost.

5.13 Control of Pollution / Health Hazards

- 5.13.1** The Contractor shall take care to comply with current legislation on the Control of Pollution.

5.14 Site-In charge / Log Book / Hindrance & other Records

- 5.14.1** One fully responsible and experienced & Qualified Site-in-charge (Minimum Qualification: Diploma with 5 years' experience) has to be posted at the site during progress of work.

- 5.14.2** One dedicated and experienced / Qualified Safety Officer at site having requisite qualification in Industrial Safety, recognized by the State Govt. / AICTE and working experience in industry / project work. The credentials of the vendor's safety personnel are to be submitted to Unit Safety Department duly endorsed by the concerned stakeholders mentioning the relevant P.O. No.
- 5.14.3** Details of technical personnel deployed for the job.
- 5.14.4** Log book for re-work/ modification.
- 5.14.5** Site instruction book.
- 5.14.6** Details of materials brought by vendor along with copies of challan.
- 5.14.7** Proper record of hindrances is to be maintained by the contractor for the purpose of timely removal of the hindrance and is to be put up for approval by the Engineer on weekly basis.

5.15 Clearance of Site

- 5.15.1** During construction work, the Contractor shall remove all unsalvageable dismantled materials, dismantled concrete, translucent sheets, north light glazing, excavated surplus earth etc. as directed by the Engineer from the site progressively so that construction activities remain unaffected. These materials shall be disposed off to a suitable area (to be arranged by the Contractor in conformity with statutory rules) outside the GRSE premises.
- 5.15.2** On receiving the Completion Certificate, the Contractor shall remove any remaining Contractor's Equipment, surplus material, scrap materials, wreckage, debris, rubbish and temporary works from the Site or as directed by the Engineer.
- 5.15.3** The site shall be handed over in a tidy and workmanship manner.
- 5.15.4** If all these items have not been removed within 28 (twenty-eight) days, after the issue of Completion Certificate the Owner may sell or otherwise dispose of any remaining items. The Owner shall be entitled to be paid the costs incurred in connection with, or attributable to, such sale or disposal and restoring the Site.

6 GRSE SCOPE

6.1 Electricity

- 6.1.1** GRSE will provide electrical power supply at one point / suitable location near the construction area / site at free of cost for execution of job. The Contractor shall make necessary arrangements for further distribution, as required, from that point on a temporary basis all at his own cost. The contractor shall ensure consumption of power in very economical way to save energy.

6.2 Water

- 6.2.1** Construction water will be provided at free of cost from existing source of GRSE. The Contractor shall arrange necessary water distribution pipe line and pump as required all at his own cost.

7 SPECIAL TERMS AND CONDITIONS OF CONTRACT

7.1 Technical Eligibility Criteria

7.1.1 Bidder shall have experience of successful execution of Similar Nature /Type of Job i.e. Construction of Concrete pavement/Hardstand, Construction of Building or Industrial Shed or any civil related structure including related civil work during last Seven (07) years. It may kindly be noted that value of Concreting and Reinforcement steel taken together (not structural steel) (including GST) should be at least 40% of total work order value (i.e. such value will be calculated by combining only the eligible orders as per Clause No 7.1.2 i.e. the total value of Concreting and Reinforcement of all eligible order should be at least 40% of total value of all eligible order), otherwise bidder will not be considered for evaluation. Supporting documents meeting Technical Eligibility Criteria to be submitted along with the bid. Also, full contact details like name, address, telephone numbers of the person under whose direct jurisdiction the work was executed etc.) to prove that they had carried out such works successfully in any PSU / Corporate house / Industry.

7.1.2 Bidder has to fulfill experience in successful completion of aforesaid similar jobs of value (including GST) not less than Rs. 480 Lac for one job OR not less than Rs. 300 Lac each for two jobs OR not less than Rs.240 Lac each for three jobs in last Seven (07) years. The bidder must submit necessary proof duly endorsed along with the bid.

OR

Bidder has to fulfill experience in partial completion of aforesaid similar jobs of value (including GST) not less than Rs. 480 Lac for one job OR not less than Rs. 300 Lac each for two jobs OR not less than Rs.240 Lac each for three jobs in last Seven (07) years. The bidder must submit necessary proof for partial completion certificate indicating the aforesaid value as mentioned above duly endorsed from the engaging authority along with the bid.

7.2 Site Condition

7.2.1 The Tenderer shall consider that accommodation for personnel of the Contractor and their sub-contractors is not allowed to reside at GRSE premises.

7.2.2 All the work sites are within the compound of a running engineering works and the Contractor's works will have to be carried out in a manner so as to avoid interruption in the normal shipyard production activities. Accordingly, the Contractor is to co-operate with GRSE to minimize disruption to shipbuilding activities and is to preserve and maintain GRSE vehicular access route for the transport of ship blocks etc.

7.2.3 Tenderer must carefully consider his method of construction and safety of the works in relation to environmental factors and the ground conditions.

7.2.4 Before quoting, the Tenderer in his own interest shall carry out site visits to know the site conditions / situations and full implications of the assignment. This will also help him in proper assessment of the work. Failure to do so will not absolve the contractor of his responsibility to

carry out the work as specified in the Tender Documents. The cost of visiting the site shall be borne by the Tenderer and shall be at his own responsibility and risk.

7.3 Award of Works

7.3.1 It may kindly be noted that GRSE Ltd. at its discretion intends to distribute the total job between 02 (Two) parallel contractors. The established rate with L1 bidder will be offered to the other bidders as per their chronological ranking based on their quoted price (L1, L2/L3/L4) and by distributing the job in the ratio of 60:40 approximately

7.4 Site Consultations

7.4.1 The work shall be carried out in consultation with the Yard Modernisation Department of GRSE headed by Addl. General Manager (YM), with other officers as nominated by him.

7.5 Work Done Certificate (W.D.C.)

7.5.1 The contractor will put up Work done for certification to Engineer along with all inspection report / measurement sheet signed by Quality Assurance Authority/Engineer. Work done certificate is to include whether work has been completed as per delivery schedule or the delay in days/weeks occurred in completion of work. Any recovery towards usage of GRSE resources is also to be indicated.

7.6 Completion Period

7.6.1 Completion period of the entire scope of work under this tender shall be: -

Total 05 (Five) calendar months from the date of issue of Letter of Award (LOA) or signing of contract agreement whichever is earlier. 15 days mobilization time will be provided separately over and above of 05 months as mentioned above after placement of LOA/ PO whichever is earlier.

7.6.2 The Tenderer, however, is required to assess the period and confirm the completion period. The tenderer must submit a network schedule (in MS Projects) explaining planning and program in detail for execution of the project.

7.7 Guarantee Period / Defect Liability Period (DLP)

7.7.1 The work executed including supplied components thereof are to be guaranteed for satisfactory performance for the period of 12 (Twelve) Calendar months from the date mentioned in the Completion Certificate, unless otherwise agreed in writing by the Engineer. This will be deemed as the 'Guarantee Period'/ 'Defect Liability Period'.

7.8 Submission of RA Bills by the Contractor

7.8.1 The Contractor shall submit to the Engineer, RA bills (in triplicate) for the payments, for the amount due along with all relevant documents each signed by the Contractor's authorised representative, such interim measurement and valuation of the works, material entry documents, etc. signed by the Engineer's Representative, certificates of inspection/ trials, as may be applicable to respective stages. Works completed shall be jointly measured by the Contractor & Engineer /Engineer's representative.

7.9 Ownership of Scrap

7.9.1 All scrap items (salvageable) i.e. Metal scrap materials (loose) if obtained/generated by demolishing of any structure / during excavation shall remain the property of the Owner/GRSE and shall be shifted and stacked at place earmarked by owner within GRSE premises. However, steel embedded within concrete shall be disposed of from site by the Contractor along-with excess earth, debris and rubbish etc.

7.10 Completion Certificate

7.10.1 When the whole of the work has been completed to the satisfaction of the Engineer and has passed any final test as per the Specification/Contract/ instruction of the Engineer, the Contractor shall, within 21 (twenty-one) days of submission of his application to the Engineer, be entitled to receive a "Certificate for Completion" of work.

7.10.2 If any part of the total work having been completed to the satisfaction of the Engineer, be taken over and / or used by the Owner, the Contractor shall on application be entitled to partial completion certificate indicating the portion of the work covered by it, so that the Contractor's liability during Defect Liability Period of the Contract, if any, shall commence from the date mentioned in such certificate so far as the completed portion of the work is concerned.

7.11 Variation and its Valuation

The Engineer shall have the power to order the Contractor in writing to make any variation of the quantity, quality or form of the works or any part thereof that may, in his opinion, be necessary and the Contractor upon receipt of such an order shall act as follows:

- a) Increase or decrease the quantity of any work included in the Contract.
- b) Omit any work included in the Contract.
- c) Change the character or quality of kind of any work included in the Contract.
- d) Execute extra and additional work of any kind necessary for completion of the works.

7.11.1 Quantities in Price Schedule are estimated

Quantity of various items mentioned in BOQ as part of SOTR given in the tender is tentative. The detail BOQ is attached with the SOTR. Individual item quantity may vary according to actual requirement of job during the tenure of the work/contract at any extent. The Contractor shall assess actual quantity of work based on drawings and requirements of Owner (to be decided by Engineer) and shall submit updated BOQ incorporating quantity variation to the Engineer for review/approval. Variation (upward/downward) in quantity (without any limit) and value shall no way vitiate or

invalidate the Contract or be treated as revocation of the Contract, but the value (if any) of all such variations evaluated shall be considered and the Contract Price shall be varied accordingly without any change in agreed rates of Price Schedule/BOQ on account of variation. Due to above quantity variation in individual items, the total Purchase Order Value may vary for successful completion of the job. Necessary amendment of PO will be issued accordingly. Limit on Cost of Variation & Value of contract may vary up to a maximum of 25% of the total Contract Value. This is to be a cumulative total for all variations. The Contractor shall give reasonable prior notice to the Engineer of any variation which may cause this cumulative limit to be exceeded.

7.11.2 Payment for Extra, Additional, Omitted, Substituted Work

1. The Contractor shall not be entitled to any claim of additional work unless they have been carried out under the written orders of the Engineer.
2. The Engineer shall solely determine the amount (if any) to be added to or deducted from the sum named in the Tender in respect of any additional work done or work omitted by his order subject to approval of the Owner.
3. All additional or substituted work done or work omitted by order of the Engineer shall be valued on the basis of the rates and prices set out in the Contract, if in the opinion of the Engineer, the same shall be applicable. If the Contract does not contain any rates or prices directly applicable to the extra, additional or substituted work, the Engineer shall solely determine suitable rates in the manner deemed by him as fair and reasonable, and his decision shall be final, binding and conclusive.
4. Rates of item of work that is not included in the schedule of items/BOQ shall be fixed as per the following procedure:
 - (a) Where the extra works are of similar character and of equivalent value and / or executed under similar conditions as to any item of work appearing at Schedule of Quantities, then the rates for such extra items shall be equal to the rates of such items.
 - (b) If the extra works are of similar character but differing in particulars then the rate of such item or items shall be derived from Schedule of Quantities, as modified to take fair account of the differences in particulars.
 - (c) Where items of similar character are not contained in the Schedule of Quantities and none of the foregoing methods are applicable, rates shall be based on the norms of PWD/CPWD for labour, materials content respectively.
 - (d) Where rates for extra item of works cannot be established by rate analysis as per the above, then rate for such item shall be estimated and fixed by the Engineer based on the market rates and assessment for labour, materials and other factors involved thereon.

*******END*******

Package-1

Sl No	Description of Item	Qnty	Unit	Rate (Rs)	Amount (Rs)
1	Detail survey of the proposed hard stand area using Auto Level/Total station and necessary design, drawing and detailing for the project. (All drawing should be submitted both in hard and soft copies along with PDF & Auto Cad files)	8200.00	Sqm		
2	Dismantling of flexible pavements and disposal of dismantled materials upto a lead of 100 m, stacking serviceable and unserviceable materials separately as per Technical Specifications Clause 202 for Rural Roads of MORD. Bituminous Courses	9.00	Cum		
3	Dismantling of flexible pavements and disposal of dismantled materials upto a lead of 100 m, stacking serviceable and unserviceable materials separately as per Technical Specifications Clause 202 for Rural Roads of MORD. Granular Courses	15.00	Cum		
4	Dismantling all types of plain cement concrete works, stacking serviceable materials at site and removing rubbish as directed within a lead of 75 m.	60.00	Cum		
5	Dismantling R.C. floor, roof, beams etc. including cutting rods and removing rubbish as directed within a lead of 75 m. including stacking of steel bars	60.00	Cum		
6	Dismantling all types of masonry excepting cement concrete plain or reinforced, stacking serviceable materials at site and removing rubbish as directed within a lead of 75 m.	60.00	Cum		
7	Labour for lowering and stacking after dismantling in parts R.S. joists, channels, angles, tees, plates etc.complete as directed.	60.00	Qntl		
8	Removal of rubbish,earth etc. from the working site and disposal of the same beyond the compound, in conformity with the Municipal/Corporation Rules for such disposal, loading into truck and cleaning the site in all respect as per direction of Engineer in charge.	180.00	Cum		

9	Surface Dressing of the ground in any kind of soil including removing vegetation inequalities not exceeding 15 cm depth and disposal of the rubbish within a lead upto 75 m as directed.	9000.00	Sqm		
10	Earth work in excavation of foundation trenches or drains, in all sorts of soil including removing, spreading or stacking the spoils within a lead of 75 m. as directed.	360.00	Cum		
11	Earth work in filling in foundation trenches or plinth with good earth, in layers not exceeding 150 mm. including watering and ramming etc. layer by layer complete,With earth obtained from excavation of foundation	80.00	Cum		
12	Levelling and Compacting original ground (Sub Grade) by power roller of capacity 80Kn to 100 Kn including filling in depression occur during rolling to obtain the desired dry density	800.00	Cum		
13	Filling in foundation or plinth by silver sand in layers not exceeding 150 mm as directed and consolidating the same by thorough saturation with water, ramming complete including the cost of supply of sand	71.00	Cum		
14	Single Brick Flat Soling of picked jhama bricks including ramming and dressing bed to proper level and filling joints with local sand.	81.00	Sqm		
15	Brick work with 1st class bricks in cement mortar (1:4) In superstructure, ground floor	105.00	Cum		
16	Ordinary Cement concrete (mix 1:2:4) with graded stone chips (20 mm nominal size) excluding shuttering and reinforcement,if any, in ground floor as per relevant IS codes.	60.00	Cum		
17	Supplying, spreading and consolidating an uniform and homogeneous mixture of Stone Dust and Sand (mixed in proportion of 3 : 1 by volume and by any approved method as per direction of Engineer-in- Charge) to the required thickness in layers at 97% Proctor Density (not less than 1.7 gm/cc) with power roller to proper gradient and camber, including watering as necessary, lighting, guarding, barricading and making adequate earthen bundh where necessary to protect the edges and curing with water for 2 to 3 days, mending cracks and depressions by rolling where necessary complete as per Specification including all incidental charges of roller, cost of fuel & lubricants. The compaction factor is 0.67.	1200.00	Cum		

	Note: Rolling should also be done before spreading of mixture of stone dust and sand				
18	Supplying ready mixed concrete of M 30 Grade with well graded stone chips of 20 mm nominal size containing designed quantity of cement per Cu.m of wet concrete produced in computerised batching plant under controlled condition using approved super plastisizer, designing concrete mix following I.S. 10262 and I.S. 456, transporting the mix with agitation in transit mixer to work site depositing the mix on a platform erected for the purpose at required levels of concreting and then placing the mix in its final location of form work, compacting and curing the same complete as per specification & direction of the Engineer-in-charge including computerised batching plant transit mixer with all accessories vibrators etc. inclusive of all other incidental charges in this connection complete but excluding cost of hire charge of platform and its supporting staging which would be paid through separate item. ii)With approved concrete pump	2004.00	Cum		
19	Supplying ready mixed Steel fibre(steel fibre dosage-20 Kg/Cum) concrete of M 30 Grade with well graded stone chips of 20 mm nominal size containing designed quantity of cement per Cu.m of wet concrete produced in computerised batching plant under controlled condition using approved super plastisizer, designing concrete mix following I.S. 10262 and I.S. 456, transporting the mix with agitation in transit mixer to work site depositing the mix on a platform erected for the purpose at required levels of concreting and then placing the mix in its final location of form work, compacting and curing the same complete as per specification & direction of the Engineer-in-charge including computerised batching plant transit mixer with all accessories vibrators etc. inclusive of all other incidental charges in this connection complete but excluding cost of hire charge of platform and its supporting staging which would be paid through separate item. ii)With approved concrete pump	172.00	Cum		

20	Providing, erecting & fixing in position steel shuttering at all locations for all shapes etc in all complete including deshuttering of the same after specified period without damaging the concrete works as directed by Engineer-incharge, etc. Providing and applying approved form oil on all surfaces of formwork coming in contact with concrete as per specifications and drawings and as directed by Engineerin-charge.	1,680.00	Sq.m		
21	Reinforcement for reinforced concrete work in all sorts of structures including distribution bars, stirrups, binders , dowel bar (dowel bar should be installed as per normal practice) etc initial straightening and removal of loose rust (if necessary), cutting to requisite length, hooking and bending to correct shape, placing in proper position and binding with 16 gauge black annealed wire at every intersection, complete as per drawing and direction (Sail/Tata/RINL)	202.00	MT		
22	Supplying and laying Polythene Sheet (150gm / sq.m.) over damp proof course or below flooring or roof terracing or in foundation or in foundation trenches	9000.00	Sq.m		
23	M.S. structural works in columns, beams etc. with simple rolled structural members (e.g. joists, angle, channel sections conforming to IS: 226, IS: 808 & SP (6)- 1964 connected to one another with bracket, gussets, cleats as per design, direction of Engineer-in-charge complete including cutting to requisite shape and length, fabrication with necessary bolting, metal arc welding conforming to IS: 816- 1969 & IS: 1995 using electrodes of approved make and brand conforming to IS:814- 2004, haulage, hoisting and erection all complete. The rate includes the cost of rolled steel section, consumables such as electrodes, gas and hire charge of all tools and plants and labour required for the work including all incidental chages such as electricity charges, labour insurance charges etc.	20.00	MT		
24	Plaster (to wall, floor, ceiling etc.) with sand and cement mortar including rounding off or chamfering corners as directed and raking out joints including throating, nosing and drip course, scaffolding/staging where necessary,With 1:4 cement mortar,15 mm thick plaster	840.00	Sq.m		

25	Neat cement punning about 1.5mm thick in wall, dado, window sill, floor etc	816.00	Sqm		
26	Applying Exterior grade Acrylic primer of approved quality and brand on plastered or concrete surface old or new surface to receive decorative textured (matt finish) or smooth finish acrylic exterior emulsion paint including scraping and preparing the surface thoroughly, complete as per manufacturer's specification and as per direction of the EIC	900.00	Sq.m		
27	Protective and Decorative Acrylic exterior emulsion paint of approved quality, as per manufacturer's specification and as per direction of Engineer-in-Charge to be applied over acrylic primer as required. The rate includes cost of material, labour, scaffolding and all incidental charges but excluding the cost of primer	900.00	Sqm		
28	Priming one coat on steel or other metal surface with synthetic oil bound primer of approved quality including smoothening surfaces by sand papering etc	492.00	Sqm		
29	Painting with best quality synthetic enamel paint of approved make and brand including smoothening surface by sand papering etc. including using of approved putty etc. on the surface, if necessary, On steel or other metal surface, With other than hi-gloss of approved quality, Two coats (with any shade except white)	492.00	Sqm		
30	Supplying & laying Double Wall Corrugated (with external annular corrugation and smooth internal walls) High Density Polyethelene Pipes conforming to IS 16098 (Part-II):2013 having Stiffness Class of SN 8 with Ring Stiffness not less than 8.00 KN/Sqm. and Impact Resistance TIR value not more than 10% including necessary jointing materials for nonpressure underground Drainage, Sewerage & Cross drainage application. 300mm internal dia.	330.00	M		
31	Filler joint Providing and filling joint sealing compound as per drawings and technical specifications with coarse sand and 6% bitumen by weight	3000.00	M		

32	Painting Lines, Dashes, Arrows etc on Roads in Two Coats on New Work Painting lines, dashes, arrows etc on roads in two coats on new work with ready mixed road marking paint conforming to IS:164 on bituminous surface/concrete surface, including cleaning the surface of all dirt, dust and other foreign matter, demarcation at site and traffic control (Reference to MORT&H's specification 803). (ii) Up to 10 cm in width	60.00	Sqm		
33	Painting Lines, Dashes, Arrows etc on Roads in Two Coats on Old Work Painting lines, dashes, arrows etc on roads in two coats on old work with ready mixed road marking paint conforming to IS: 164 on bituminous surface/concrete, including cleaning the surface of all dirt, dust and other foreign matter, demarcation at site and traffic control (Reference to MORT&H's specification 803). (ii) Up to 10 cm in width	36.00	Sqm		
34	Providing and laying reinforced cement concrete pipe NP4 with spigot socket for culverts on first class bedding of granular material in single row including fixing with cement mortar 1:2 as per Technical Specification Clause 1106 for Rural Roads of MORD 300MM	15.00	RM		
35	Supplying and Planting of different plant / trees (Supplying well grown plants bushy and healthy, minimum height as specified i.e. exposed height including all leads & lift, carriage, handling, manuring, applying pesticide and fertilizer etc.	6.00	Each		
	Relocation/transplantation of whole tree/plant by uprooting it from its old location to plug it into the new position as per the direction of EIC	15.00	Each		

Package-2

Sl No	Description of Item	Qnty	Unit	Rate (Rs)	Amount (Rs)
1	Detail survey of the proposed hard stand area using Auto Level/Total station and necessary design, drawing and detailing for the project. (All drawing should be submitted both in hard and soft copies along with PDF & Auto Cad files)	6300.00	Sqm		

2	Dismantling of flexible pavements and disposal of dismantled materials upto a lead of 100 m, stacking serviceable and unserviceable materials separately as per Technical Specifications Clause 202 for Rural Roads of MORD. Bituminous Courses	6.00	Cum		
3	Dismantling of flexible pavements and disposal of dismantled materials upto a lead of 100 m, stacking serviceable and unserviceable materials separately as per Technical Specifications Clause 202 for Rural Roads of MORD. Granular Courses	10.00	Cum		
4	Dismantling all types of plain cement concrete works, stacking serviceable materials at site and removing rubbish as directed within a lead of 75 m.	40.00	Cum		
5	Dismantling R.C. floor, roof, beams etc. including cutting rods and removing rubbish as directed within a lead of 75 m. including stacking of steel bars	40.00	Cum		
6	Dismantling all types of masonry excepting cement concrete plain or reinforced, stacking serviceable materials at site and removing rubbish as directed within a lead of 75 m.	40.00	Cum		
7	Labour for lowering and stacking after dismantling in parts R.S. joists, channels, angles, tees, plates etc.complete as directed.	50.00	Qntl		
8	Removal of rubbish,earth etc. from the working site and disposal of the same beyond the compound, in conformity with the Municipal/Corporation Rules for such disposal, loading into truck and cleaning the site in all respect as per direction of Engineer in charge.	120.00	Cum		
9	Surface Dressing of the ground in any kind of soil including removing vegetation inequalities not exceeding 15 cm depth and disposal of the rubbish within a lead upto 75 m as directed.	6000.00	Sqm		
10	Earth work in excavation of foundation trenches or drains, in all sorts of soil including removing, spreading or stacking the spoils within a lead of 75 m. as directed.	240.00	Cum		

11	Earth work in filling in foundation trenches or plinth with good earth, in layers not exceeding 150 mm. including watering and ramming etc. layer by layer complete,With earth obtained from excavation of foundation	52.00	Cum		
12	Levelling and Compacting original ground (Sub Grade) by power roller of capacity 80Kn to 100 Kn including filling in depression occur during rolling to obtain the desired dry density	400.00	Cum		
13	Filling in foundation or plinth by silver sand in layers not exceeding 150 mm as directed and consolidating the same by thorough saturation with water, ramming complete including the cost of supply of sand	47.00	Cum		
14	Single Brick Flat Soling of picked jhama bricks including ramming and dressing bed to proper level and filling joints with local sand.	54.00	Sqm		
15	Brick work with 1st class bricks in cement mortar (1:4) In superstructure, ground floor	70.00	Cum		
16	Ordinary Cement concrete (mix 1:2:4) with graded stone chips (20 mm nominal size) excluding shuttering and reinforcement,if any, in ground floor as per relevant IS codes.	40.00	Cum		
17	Supplying, spreading and consolidating an uniform and homogeneous mixture of Stone Dust and Sand (mixed in proportion of 3 : 1 by volume and by any approved method as per direction of Engineer-in- Charge) to the required thickness in layers at 97% Proctor Density (not less than 1.7 gm/cc) with power roller to proper gradient and camber, including watering as necessary, lighting, guarding, barricading and making adequate earthen bundh where necessary to protect the edges and curing with water for 2 to 3 days, mending cracks and depressions by rolling where necessary complete as per Specification including all incidental charges of roller, cost of fuel & lubricants. The compaction factor is 0.67. Note: Rolling should also be done before spreading of mixture of stone dust and sand	500.00	Cum		

18	<p>Supplying ready mixed concrete of M 30 Grade with well graded stone chips of 20 mm nominal size containing designed quantity of cement per Cu.m of wet concrete produced in computerised batching plant under controlled condition using approved super plastisizer, designing concrete mix following I.S. 10262 and I.S. 456, transporting the mix with agitation in transit mixer to work site depositing the mix on a platform erected for the purpose at required levels of concreting and then placing the mix in its final location of form work, compacting and curing the same complete as per specification & direction of the Engineer-in-charge including computerised batching plant transit mixer with all accessories vibrators etc. inclusive of all other incidental charges in this connection complete but excluding cost of hire charge of platform and its supporting staging which would be paid through separate item. ii)With approved concrete pump</p>	1336.00	Cum		
19	<p>Supplying ready mixed Steel fibre(steel fibre dosage-20 Kg/Cum) concrete of M 30 Grade with well graded stone chips of 20 mm nominal size containing designed quantity of cement per Cu.m of wet concrete produced in computerised batching plant under controlled condition using approved super plastisizer, designing concrete mix following I.S. 10262 and I.S. 456, transporting the mix with agitation in transit mixer to work site depositing the mix on a platform erected for the purpose at required levels of concreting and then placing the mix in its final location of form work, compacting and curing the same complete as per specification & direction of the Engineer-in-charge including computerised batching plant transit mixer with all accessories vibrators etc. inclusive of all other incidental charges in this connection complete but excluding cost of hire charge of platform and its supporting staging which would be paid through separate item. ii)With approved concrete pump</p>	258.00	Cum		

	Providing, erecting & fixing in position steel shuttering at all locations for all shapes etc in all complete including deshuttering of the same after specified period without damaging the concrete works as directed by Engineer-incharge, etc. Providing and applying approved form oil on all surfaces of formwork coming in contact with concrete as per specifications and drawings and as directed by Engineerin-charge.	1,120.00	Sq.m		
21	Reinforcement for reinforced concrete work in all sorts of structures including distribution bars, stirrups, binders , dowel bar (dowel bar should be installed as per normal practice) etc initial straightening and removal of loose rust (if necessary), cutting to requisite length, hooking and bending to correct shape, placing in proper position and binding with 16 gauge black annealed wire at every intersection, complete as per drawing and direction (Sail/Tata/RINL)	118.00	MT		
22	Supplying and laying Polythene Sheet (150gm / sq.m.) over damp proof course or below flooring or roof terracing or in foundation or in foundation trenches	6000.00	Sq.m		
23	M.S. structural works in columns, beams etc. with simple rolled structural members (e.g. joists, angle, channel sections conforming to IS: 226, IS: 808 & SP (6)- 1964 connected to one another with bracket, gussets, cleats as per design, direction of Engineer-in-charge complete including cutting to requisite shape and length, fabrication with necessary bolting, metal arc welding conforming to IS: 816- 1969 & IS: 1995 using electrodes of approved make and brand conforming to IS:814- 2004, haulage, hoisting and erection all complete. The rate includes the cost of rolled steel section, consumables such as electrodes, gas and hire charge of all tools and plants and labour required for the work including all incidental chages such as electricity charges, labour insurance charges etc.	14.00	MT		
24	Plaster (to wall, floor, ceiling etc.) with sand and cement mortar including rounding off or chamfering corners as directed and raking out joints including throating, nosing and drip course, scaffolding/staging where necessary,With 1:4 cement mortar,15 mm thick plaster	560.00	Sq.m		

25	Neat cement punning about 1.5mm thick in wall, dado, window sill, floor etc	544.00	Sqm		
26	Applying Exterior grade Acrylic primer of approved quality and brand on plastered or concrete surface old or new surface to receive decorative textured (matt finish) or smooth finish acrylic exterior emulsion paint including scraping and preparing the surface thoroughly, complete as per manufacturer's specification and as per direction of the EIC	600.00	Sq.m		
27	Protective and Decorative Acrylic exterior emulsion paint of approved quality, as per manufacturer's specification and as per direction of Engineer-in-Charge to be applied over acrylic primer as required. The rate includes cost of material, labour, scaffolding and all incidental charges but excluding the cost of primer	600.00	Sqm		
28	Priming one coat on steel or other metal surface with synthetic oil bound primer of approved quality including smoothening surfaces by sand papering etc	328.00	Sqm		
29	Painting with best quality synthetic enamel paint of approved make and brand including smoothening surface by sand papering etc. including using of approved putty etc. on the surface, if necessary, On steel or other metal surface, With other than hi-gloss of approved quality, Two coats (with any shade except white)	328.00	Sqm		
30	Supplying & laying Double Wall Corrugated (with external annular corrugation and smooth internal walls) High Density Polyethelene Pipes conforming to IS 16098 (Part-II):2013 having Stiffness Class of SN 8 with Ring Stiffness not less than 8.00 KN/Sqm. and Impact Resistance TIR value not more than 10% including necessary jointing materials for nonpressure underground Drainage, Sewerage & Cross drainage application. 300mm internal dia.	220.00	M		
31	Filler joint Providing and filling joint sealing compound as per drawings and technical specifications with coarse sand and 6% bitumen by weight	2000.00	M		

32	Painting Lines, Dashes, Arrows etc on Roads in Two Coats on New Work Painting lines, dashes, arrows etc on roads in two coats on new work with ready mixed road marking paint conforming to IS:164 on bituminous surface/concrete surface, including cleaning the surface of all dirt, dust and other foreign matter, demarcation at site and traffic control (Reference to MORT&H's specification 803). (ii) Up to 10 cm in width	40.00	Sqm		
33	Painting Lines, Dashes, Arrows etc on Roads in Two Coats on Old Work Painting lines, dashes, arrows etc on roads in two coats on old work with ready mixed road marking paint conforming to IS: 164 on bituminous surface/concrete, including cleaning the surface of all dirt, dust and other foreign matter, demarcation at site and traffic control (Reference to MORT&H's specification 803). (ii) Up to 10 cm in width	40.00	Sqm		
34	Providing and laying reinforced cement concrete pipe NP4 with spigot socket for culverts on first class bedding of granular material in single row including fixing with cement mortar 1:2 as per Technical Specification Clause 1106 for Rural Roads of MORD 300MM	10.00	RM		
35	Supplying and Planting of different plant / trees (Supplying well grown plants bushy and healthy, minimum height as specified i.e. exposed height including all leads & lift, carriage, handling, manuring, applying pesticide and fertilizer etc.	4.00	Each		
36	Relocation/transplantation of whole tree/plant by uprooting it from its old location to plug it into the new position as per the direction of EIC	10.00	Each		

TYPICAL DRAWING OF CONCRETE JOINT

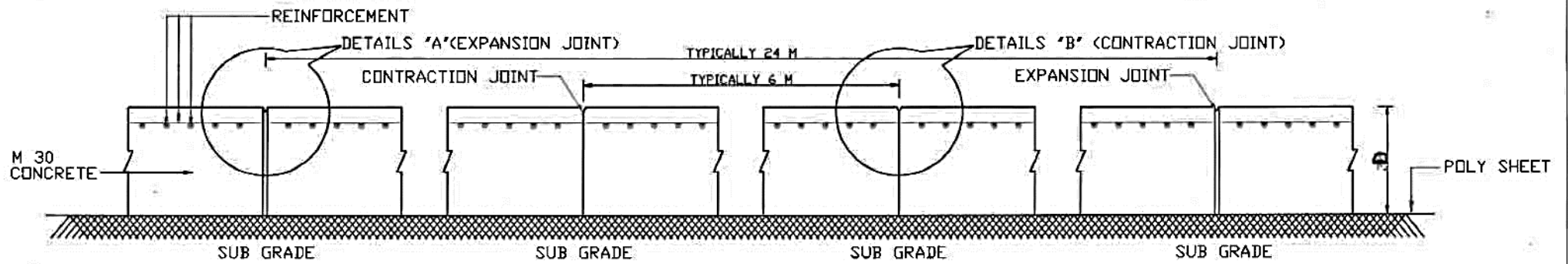

TYPICAL SECTION

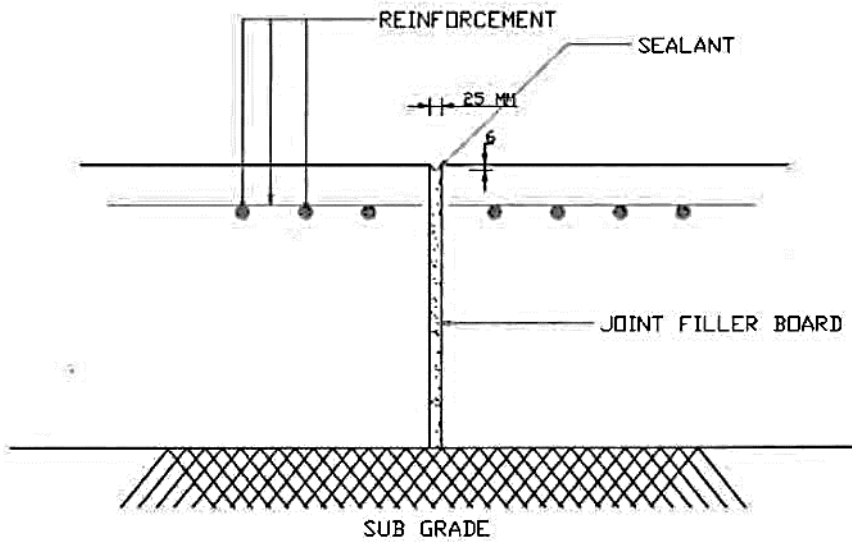

DETAILS "A" (EXPANSION JOINT)

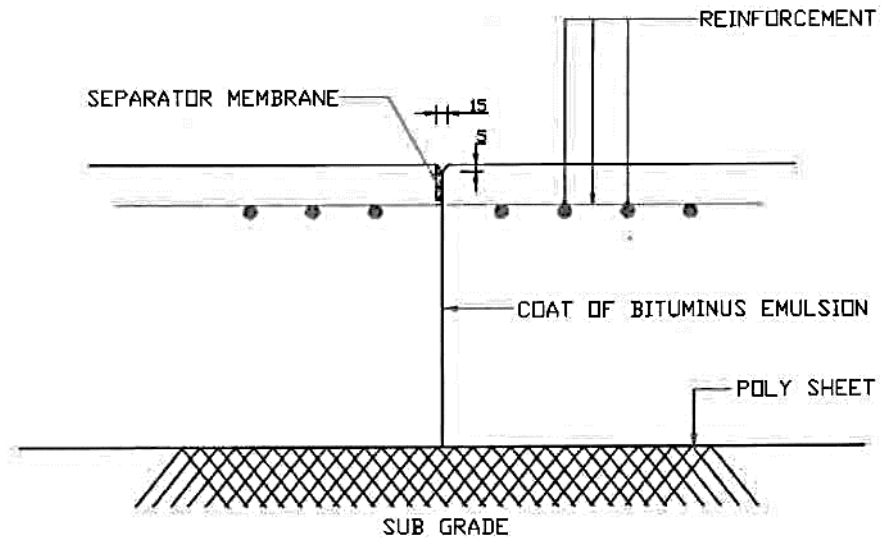

DETAILS "B" (CONTRACTION JOINT)

H O O G I L Y R I V E R

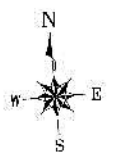

STANDARD TERMS & CONDITIONS (STAC)

मानक निबंधन और शर्तें (एसटीएसी)

(1) INTEGRITY PACT समग्रताअनुबंध:

All the participating vendors in this tender are required to enter into agreement by signing an Integrity Pact.

“The Pact essentially envisages as agreement between the prospective vendors/bidders and the buyer, committing the persons/officials of both the parties, not to exercise any corrupt influence on any aspect of the contract”.

Signing of Integrity Pact will be preliminary qualification for participation of this tender, only those vendors who have entered into this Pact with GRSE will qualify for the contract. This Integrity Pact will be effective from the stage of invitation of bids till the date of complete execution of this contract.

Signing Authority for Integrity Pact:

(A) Vendor: Proprietor / Director / Authorized representative

(B) GRSE: Head of the ordering department, not below the rank of DGM / AGM

Vendors need to sign on each page of the Integrity Pact document and provide the same on a Govt. issued bond paper of Rs.100/-. The scanned copy of the same need to be uploaded along with the technical Bid documents and original copy of the same to be forwarded to Tendering Department before the due date of the tender.

The vendor has to submit Integrity Pact as per GRSE Format along with Techno-commercial bid, wherever applicable as per NIT.

(2) MICRO & SMALL ENTERPRISE (सूक्ष्मऔरछोटेउद्यम) -

- a) Purchase preference will be given to eligible Micro and Small Enterprise firms as per MSME Act on submission of valid Udyam Registration Certificate (URC) or NSIC copy along with their offer to claim the benefit. Tendered Service is to be listed in the URC or NSIC submitted else they are disqualified to avail the benefit.
- b) Out of 25% target of annual procurement from MSEs, 4% (within the 25%) reservation will be provided for MSEs owned by Schedule Caste (SC) /Scheduled Tribe (ST) entrepreneurs and 3% (within the 25%) reservation will be provided for MSEs owned by women entrepreneurs. Necessary documents to be submitted along with the techno-commercial bid as evidence failing which benefit shall not be accorded. However, in the event of failure of such MSEs to participate in the tender process or meet the tender requirements and L1 price, 4% reservation for MSEs owned by SC/ST entrepreneurs and 3% reservation for MSEs owned by women entrepreneurs will be met from other MSEs.
- c) Following facilities/benefits may be given to MSEs: -
 - (i) Exemption for payment of Tender Fee & Earnest Money Deposit.
- d) (i) MSEs registered with MSME authority as stated above, quoting price within the band of L1 +15% will be allowed to supply a portion of the requirement by bringing

down their price to L1 price in a situation where the L1 price is from someone other than MSE. Such MSEs will be allowed to supply at least 25% of total tendered value. To avail this purchase preference, submission of Udyam Registration Certificate /NSIC is mandatory failing which the benefit will not be accorded.

(ii) In case L1 is not an MSE and there is more than one MSE within the range of L1 +15%, only the lowest MSE shall be considered for 25% order in case of divisible item or 100% in case the order quantity is not divisible, subject to matching the L1 prices.

(iii) If the lowest MSE refuses to accept the L1 price, then the second lowest MSE within the range of L1 +15% will be considered. This process will continue till a MSE in the range accepts the L1 price or the MSEs in the L1 + 15% range are exhausted.

(iv) In case no MSE accepts the L1 price or there is no MSE available in the L1 +15% range, then the order shall be placed to the L1 bidder without applying this principle.

- e) Non-Divisibility of Tender Items: - In case of non-divisible / non-splittable item in tenders, an MSE quoting in the price band of L1+15% may be awarded for full/complete supply of total tendered value, considering the spirit of policy for enhancing the government procurement from MSEs subject to matching the L1 prices by the MSE concerned. However, contract will be awarded as per GOI policy and at discretion of GRSE.
- f) To qualify for entitlement as SC/ST owned MSE, the SC/ST certificate issued by the District Authority must be submitted along with the offer or the same should be indicated in the relevant document NSIC / Udyam Registration Certificate.
- g) For the MSEs owned by SC/ST owned entrepreneur, the benefits as stated above shall be accorded only in the following cases:
- (i) For proprietary MSE, proprietor(s) shall be SC/ST.
 - (ii) For partnership MSE, the SC/ST partners shall be holding at least 51% shares in the unit.
 - (iii) For Private Limited Companies, at least 51% share shall be held by SC/ST promoters.

(3) **TENDER FEE (निविदाशुल्क): NON-REFUNDABLE (गैर वापसी योग्य) –**

- i. Amount of declared non-refundable tender fee is to be submitted in the form of Demand Draft / Pay Order, Payable at Kolkata and issued in favour of “Garden Reach Shipbuilders & Engineers Limited” by any Nationalized/Scheduled Bank other than Co-operative Bank. Physical DD/PO to be forwarded to Tendering Department of GRSE within 07 days of tender due date. A scanned copy of the same is to be uploaded as an attachment to the PART I of e-bid submission.
- ii. MSE registered firms having the tendered service listed in their MSE document will be eligible for exemption of tender fee. To claim the exemption, a copy of the valid MSE certificate with its annexure is to be scanned and uploaded as an attachment to the PART I of e-bid submission. The same is to be confirmed in the techno-commercial concurrence format.

iii. Non-submission of tender fee or a valid MSE certificate may lead to offer rejection.

(4) EARNEST MONEY DEPOSIT (INTEREST FREE) बयाना जमा (ब्याज रहित) -

- i. Amount of declared interest free Earnest Money Deposit (EMD) is to be submitted in form of Demand Draft / Pay Order, Payable at Kolkata and issued in favour of "Garden Reach Shipbuilders & Engineers Limited" by any Nationalized/Scheduled Bank other than Co-operative Bank. Physical DD/PO to be forwarded to Tendering Department of GRSE within 07 days of tender due date. A scanned copy of the same is to be uploaded as an attachment to the PART I e-bid submission.
- ii. EMD may also be submitted in the form of Bank Guarantee with six months validity as per enclosed GRSE format of Bank Guarantee and is to be forwarded directly to GM (Finance), GRSE in Bankers' sealed envelope failing which same will not be accepted. Details of B.G. are to be in Techno-Commercial part of offer.
- iii. MSE registered firms having the tendered service listed in their MSE document will be eligible for exemption from submitting EMD. To claim the exemption a copy of the valid MSE certificate with its annexure is to be scanned and uploaded as an attachment to the General Document part of E-PROCUREMENT. The same is to be confirmed in the PART I concurrence format.
- iv. MSE Registered Firms has to be submit Bid Security Declaration In lieu of Earnest Money Deposit as per GRSE format.
- v. Non-submission of EMD /Bid Security Declaration and valid MSE certificate may lead to rejection of offer.

vi. Refund of Earnest Money Deposits (बयाना जमा की वापसी)

- a. EMD of unsuccessful bidders will be refunded/ returned within 30 days of finalisation of order on surrendering the original copy of GRSE Money Receipt with an application by bidder addressed to HOD of Ordering Department, GRSE on receipt of intimation from GRSE.
- b. EMD of disqualified bidders in TNC/CNC will be returned within 30 days from the date of receipt of application along with original copy of Money Receipt from the bidder. EMD, if not claimed within 1 year from the date of notification EMD will be forfeited.
- c. EMD of successful bidder will be returned after receipt of security deposit against work order as per contractual terms.

vii. Forfeiture of Earnest Money Deposit (बयाना जमा की जब्ती)

EMD may be forfeited under the following circumstances:

- a. The bidder withdraws the bid after opening of Price Bid during the period of validity of offer.

- b. The bidder does not accept the correction of error in bid price as indicated in **Clause 37** hereinafter.
- c. The successful bidder fails within the specifies time limit to:
 - 1. Acknowledge the LOA/Order
 - 2. Furnish the required Security Deposit
 - 3. Non-performance of the contract by the Contractor

(5) **VALIDITY OF OFFER (प्रस्ताव की वैधता) :-**

Your offer should remain valid for a period of 90 days (as per terms of specific NIT) from the due date of the tender.

(6) **SECURITY DEPOSIT (INTEREST FREE) प्रतिभूति (ब्याज रहित):**

- i. Successful bidder will deposit an amount equivalent to the declared per cent of the total contract value as interest free Security Deposit (SD) in the form of Pay Order/D. D/Bank Guarantee (with validity of sixty days beyond contract period as per GRSE format) on any schedule bank other than Co-operative bank payable at Kolkata, duly crossed favouring Garden Reach Shipbuilders & Engineers Limited., within 15 days from the date of site clearance/receipt of LOA or PO/as specified in the NIT. In case of non-submission of SD as per schedule, penal interest will be charged for delayed period of submission of SD beyond 15 days at the prevailing SBI cash credit rate on the amount of SD to be submitted.
- ii. If S.D is submitted in the form of B.G then same is to be forwarded directly to Gen. Mgr. (Finance) in Banker's sealed envelope failing which same will not be accepted. Details of B. G. should also be confirmed to Ordering Department, GRSE.
- iii. S.D. amount would be refunded / returned after successful execution of the job and certification of Material Reconciliation Statement by Internal Audit, if applicable. Vendor is to apply for release of their SD along with Job Completion Certificate which has to be certified by PL/Engineer-in-charge/authorized representative of concerned department through GRSE Ordering Dept. In the event of failure to execute the order satisfactorily or default by the contractor/ sub-contractor, the security deposit will be forfeited.

(7) **WORK DONE CERTIFICATE (W.D.C.) (किए हुए काम का प्रमाणपत्र):** - Firm will put up Work Done for certification to site engineer /PL /or as specified in the NIT, along with clear inspection report signed by Quality Assurance Authority. W.D.C. is to include whether work has been completed as per delivery schedule or the delay in days/weeks occurred in completion of work.

(8) **BILL SUBMISSION (बिल प्रस्तुति):**

On obtaining WDC, bills are to be raised on monthly/quarterly/half-yearly/annually (as specified in NIT) progressive basis in accordance with the Checklist as per GRSE format. Bills are to be submitted at the Bill Receiving Counters located at the respective unit of Company. Bill is to be submitted (in 03 copies) in sealed envelope super-scribing on the envelope the Purchase Order No., Vendor code,

Bill / Invoice No., Name of person /employee to whom bill is addressed, for processing. For this Service Name of the person to be mentioned on sealed envelope will be concerned Project Leader of the Ship/Bill certifying officer.

(9) **COMPLIANCE OF ESI & PF (ईएसआई और पीएफ़ का अनुपालन): -**

- a) Compliance of ESI & PF of the engaged workman is the responsibility of the contractor.
- b) For execution of job inside GRSE premises, vendor has to obtain clearance from HR Dept. regarding statutory compliance of minimum wages, PF, ESI, etc. of their engaged workmen for release of payment.

(10) **POLICE VERIFICATION FOR CONTRACT LABOUR WORKMEN (ठेका श्रमिकों का पुलिस सत्यापन): -**

(a) Police Verification certificates of character antecedents in respect of all employees of Contractors/Sub-contractors for operating inside GRSE Ltd. are required to be submitted to Security Dept./GRSE Ltd. before processing of Gate Passes.

(b) A certificate from the contractor's labour, clearly endorsing that characters of all his labourers have been duly verified and found to be satisfactory be submitted to GRSE at the time of making Gate Pass.

(c) Photo Identity Card /Gate Pass as required by GRSE will be arranged by the contractor for his employees at his own cost.

(11) **GST REGISTRATION (जी एस टी पंजीकरण): -** The vendor will have to submit copy of GST registration certificate (Part A & Part B) along with the Technical bid. Any bidder without having GST Registration Certificate will not be considered for Ordering.

(12) **GUARANTEE PERIOD (गारंटी अवधि): -**

Workmanship will be guaranteed for satisfactory performance for a period **as stated in NIT.** Any faulty work carried out by the sub-contractor is to be rectified by them within the time stipulated by the GRSE. In case of failure of sub-contractor to meet the ship's programme, outstanding deficiencies shall be rectified by GRSE and all costs of such work shall have to be borne by the sub-contractor).

During guarantee/ warranty period if any equipment or any component thereof supplied by the contractor, suffers due to defective material and/ or due to improper design and/ or due to defective drawing or due to faulty workmanship the contractor will assume full responsibility of rectification of such defective equipment or component thereof including all direct expenses relating to removal and re-positioning of the replacement/ repaired equipment or component thereof and subsequent test & trial, incurred thereon without any financial implication to GRSE.

(13) **PRICE (मूल्य):**

A. For Tender in NIC Portal (एन आई सी पोर्टल टेंडर हेतु): - NA

a) Price bid need to be filled up (excluding GST) in html format only through e-portal. No other attachment regarding price will be allowed, if so, then offer will be rejected. For break-up of prices, GRSE may attach excel sheet with the html format price bid and the bidder has to fill up their prices in excel sheet and also in html format as per instruction in NIT.

B. For Tender in GeM Portal (जे ई एम पोर्टल टेंडर हेतु):

a) Price bid needs to be filled up (with or without GST as specified in NIT) only through GeM portal for the total job.

b) The Bidder may have to upload the breakup of their quoted price in line with BOQ, as specified in NIT, along with their price offer in GeM portal.

c) The price should remain firm & fixed till satisfactory execution of the entire contract as per NIT. GST percentage has to be indicated in the offer. GST registration certificate for the service being tendered is to be enclosed with the techno-commercial bid. GST registration number is to be quoted in all bills.

(14) **QUANTITY VARIATION (मात्रा भेद) : As per term of NIT.** Quantity as specified in the NIT/SOTR/Price Bid is tentative and it may vary according to the actual requirement of the job. The selected bidder has to execute the required quantity at the same rate, terms & conditions up to variation (+/-25%) or as specified in the NIT in addition to the initial tendered quantity. Necessary amendment of Purchase Orders will be issued accordingly.

(15) **UNREASONABLE QUOTES अतर्कसंगत भाव -**

A. For Job Contract (कार्य संविदा हेतु) :

i) In case the price of L-1 Bidder is found to quote unreasonably low and/or express desires to withdraw from the tender then such bid will be cancelled and EMD will be forfeited and punitive action will be taken in line with the provision as per GRSE Vendor Policy.

ii) However, in case the L1 Bidder agrees to take-up the job with such unreasonable low quote, lower by 30% or more than estimate and also if the difference in price between L1 & L2 is 30% or more, then the quoted price to be analysed w.r.t tender requirement and if the L1 bidder fails to justify their quoted rate, the obtained L1 quote will be rejected and punitive action will be taken in line with the provision as per GRSE Vendor Policy.

iii) If the justification is acceptable to GRSE, then the bidder has to submit Bank Guarantee of 10% of the total Contract value (inclusive of GST) in addition to the Security Deposit (SD) and Performance Bank Guarantee (PBG) (as applicable) for execution of the job till satisfactory completion of entire contract. There shall be no exemption / relaxation for the Guarantee against unreasonable quote. In case of breach of contract GRSE shall reserve the right to invoke the BG and may impose tender holiday for a period as per GRSE Vendor policy.

B. For Manpower Contract (श्रमशक्ति संविदा हेतु): NA

- i) The quoted price of the L1 bidder should comply with the prevailing Minimum Wages Act & Other Statutory requirements i.e PF, ESI etc.
- ii) In case the quoted price of the L1 bidder is found unreasonably low i.e does not comply with the Minimum Wages Act & Other Statutory requirements and the L1 bidder fails to justify their quoted rate then the obtained L1 quote will be rejected and punitive action will be taken in line with the provision as per GRSE Vendor Policy.

(16) **JOINT VENTURE (संयुक्त ऊधम) :**

The bids submitted by a joint-venture company of two or more firms/persons/entities as partners/promoters shall comply with the following requirements:

- i) The Joint Venture Agreement must be a registered document under the Indian Registration Act and must be an independent and registered entity under the Companies Act/Indian Partnership Act, having its own trade name and having separate CIN, PAN, GST and other Statutory Licenses/Registrations independent of its promoters/partners.
- ii) All partners/promoters of the joint venture shall be liable jointly and severally for the execution/performance of the project/contract and for all sorts of contractual obligations, responsibilities and liabilities and consequences arising out of breach of terms and conditions of contract.
- iii) A Certified/True copy of the Joint Venture Agreement shall have to be submitted with the bid along with the resolution of Board of Directors (in case of a company) or a Power of Attorney to be executed by all the Partners (in case of Partnership Firm) of JV entity authorizing such person who will sign on behalf of JV entity.
- iv) Submission of EMD/SDs/Performance Guarantee etc., to be made by the Joint Venture Company/Firm and similarly all payments would also be remitted to/in favour of the JV entity.
- v) In order for a joint venture to qualify/meet the minimum criteria as may be specified in the Tender, the experience and financial capability of each of its promoters/ partners would be considered jointly to judge the experience and/or the financial capability of the JV entity as an independent entity. That is to say that the individual experience/qualification of each partner/promoter of the JV would be considered together for ascertaining the experience/qualification criteria of the JV. However, if any specific criteria/qualification is mentioned in the Tender that has to be met by each of the partners, then in such case each of the JV partner/promoters have to meet the same.
- vi) Neither the JV entity nor any of its partners/promoters should have been blacklisted, banned or debarred from issuing any Tender or suffering Tender Holiday from participating in any Tender process of Government of India or any of its Agencies or by any State Government or by an PSU (both Central & State included) or by any Court/Tribunal. If so, then the bid is liable to be rejected.

vii) If selected, PO would be issued in favour of the JV.

(17) **CONSORTIUM (अल्पकालीन संघटन):**

The bids submitted by a Consortium of two or more firms as partners shall comply with the following requirements:

- i) There must be a written Agreement for formation of the Consortium amongst its members which should *inter alia* include the role of each member, the ratio of investment and the ratio of profit/loss sharing. The terms of the Agreement cannot be modified post submission of the bid and during execution of Contract, if awarded, without the express consent of GRSE. The Consortium Agreement must record that as to which member would act as the Lead Member in the Contract/Tender. This authorization shall be evidenced by submitting with the bid a Power of Attorney authorizing such member to act on its behalf as Lead Member, signed by legally authorized signatories of all other partners/members.
- ii) Each partner firm/company of a Consortium must legally authorize its representative who will represent the partner firm/company to sign and execute the Consortium Agreement and all other necessary papers/documents required for the formation of Consortium and all other purpose relating to activities of Consortium.
- iii) The leader shall be authorized to incur liabilities and to receive instruction for and on behalf of any and all partners/members of the consortium and the entire execution of the contract and all other related documents shall be done under the supervision and involvement of the lead member.
- iv) All partners of the consortium shall be liable jointly and severally for the execution of the project or contract without any limitation of liability. Any default or lapse on the part of any of the members of the Consortium regarding performance of the contract will be treated as default on the part of the Consortium as a whole and the Lead Member alone will be responsible for all consequential losses and damages that may be sustained by GRSE for such default or lapse on the part of a member.
- v) A Certified True copy of the Consortium contract/agreement entered into by and between the consortium partners and a certified True copy of the Power of Attorney, referred above, must be submitted with the bid and failure to submit any of such documents will make the bid of the Consortium liable to be rejected.
- vi). If Contract is awarded to the Consortium, an Agreement would be executed by and between GRSE and all the Consortium members wherein, *inter alia*, the role of each member and the mode of payments to be specifically defined and/or mentioned. However, all the consortium members shall remain, jointly and severally, responsible for execution and completion of the Contract and also to make good for all losses and damages if any sustained or to be

sustained by GRSE in the subject contract due to default and/or negligence of the Consortium as a whole or of any of its members. Any statement or clause seeking to limit the liability of each member of the Consortium, such statement or clause to be treated as incompatible with the principle of joint and several liability and the bid of the Consortium will be liable to be rejected as not in compliance of tender specifications, without further evaluation.

- vii) In order to qualify/meet the qualification criteria, each of its partners/members or combination of partners/members must meet the minimum criteria set for the individual bidder. Failure to comply with this requirement will result in rejection of the Consortium's bid. The data/figures of each of the partners/members of the Consortium shall be added together in proportion to their participation in the Consortium, to determine the bidder's capacity as a whole to comply with the minimum criteria.
- viii) The percentage of partnership of the lead partner shall be highest among all the Consortium partners. Bid has to be submitted by the Lead Partner in its name however it should be clearly indicated that the lead partner is submitting such bid on behalf of a Consortium of which it is the Lead Partner.
- ix) The lead partner shall be responsible for payment of Bid Security/EMD as well as the Security Deposit & Performance Guarantee. However, the same has to be submitted by MSME/NSIC firms also if such firm acts as a Lead partner.
- x) All Payments to be made to the Lead Member pursuant to satisfactory execution of the job as specified in the Contract irrespective of the performance by all the members. Payments made to Lead partner of the Consortium would be construed as valid payment. Further the Consortium members agree not to entangle GRSE in any internal dispute between the Consortium members regarding payment/non-payment or any other issue and accordingly waives their rights, if any in this regard.
- xi) None of the consortium partners/members should have been blacklisted, banned or debarred or issued any Tender holiday from participating in Government Contracts by either the Government of India or any of its Agencies or by any State Government or by an PSU (both Central & State included) or by the Courts/Tribunals. If so, then the bid is liable to be rejected.

Note: The Consortium Agreement & the PoA is to be submitted by the Consortium's Lead partner along with the Bid for examination by GRSE. If the Consortium Agreement or the PoA does not meet the criteria as specified in the clause then such bid would be liable to be rejected.

- (18) **MAINTENANCE OF MACHINES (यंत्रों का अनुरक्षण):** - The maintenance of machines brought in by contractors are to be undertaken as per OEM recommendations. Certificate to this effect is to be rendered by the contractor.
- (19) **SUB-CONTRACTING OF SUB-CONTRACTED JOB (उप संविदा कार्य का उप संविदा)**
:-

- a) Sub-Contracting of the Sub-Contracted job is usually discouraged. When a contract is being finalised with a Vendor/ Contractor for execution of a particular job, the Contractor shall not sub-contract the job / a part of the job.
- b) However, in case of requirement, the job in part or full could be sub-contracted with an approval from GRSE and copy of the same has to be forwarded to Ordering Dept. & HR Dept. for their information.
- c) For sub-contracting of the sub-contracted job, the Vendor/Contractor has to submit the details of the sub-contractor to whom the job will be loaded including their name, credentials, document of past performance etc. for approval of GRSE Engineer In-Charge/ In-charge of User Dept./Project Leader / Project Superintendent /Head of Units.

- (20) **EXCESS/WASTE/REJECTED MATERIALS (अतिरिक्त/बेकार/ अस्वीकृत सामग्री) :-** Removal of excess/waste/rejected materials etc. generated during execution of work should be arranged by the Contractor at their own cost immediately after completion of work each day and for non-removal of same by the Contractor, the expenditure incurred by GRSE (if any) in removing these materials will be recovered from the available dues of the Contractor.
- (21) **FIRE &SAFETY PRECAUTIONS अग्नि एवं संरक्षा सावधानियाँ :-** The Vendor/Contractor shall abide by the Safety regulations/rules of the GRSE as detailed in Fire & Safety Guidelines (please refer www.grse.in). The Vendor/Contractor should take all safety precautions and provide adequate supervision & control for their workmen in order to carry out the job safely. In case of any violation of safety precaution and non-usage of safety equipment, Contractor shall be liable for a penalty which is detailed in Fire and Safety Guidelines (please refer www.grse.in). Penalty amount depends on the type and frequency of violation mentioned in the safety guideline and the same will be deducted from the defaulter's bill.
- (22) **SAFETY GUIDELINE FOR MATERIAL HANDLING EQUIPMENT (सामग्री चलान उपकरण हेतु मार्गदर्शन):** The Vendor/Contractor shall abide by the Safety Guidelines /regulations of GRSE as detailed in NIT. The Vendor/Contractor should comply with all the Safety requirements like Statutory Examination and Certification of Crane & associated lifting tackles, Display of SWL, Competency requirement of Crane Operators, PUC etc. in order to carry out the job safely. In case of any violation GRSE will take appropriate action as per policy.
- (23) **MANDATORY USE OF ISI MARKED PPE BY CONTRACTOR EMPLOYEES (संविदा कर्मचारी द्वारा आई एस आई निशान पी पी ई व्यवहार की अनिवार्यता):** The Contractor shall ensure the use of ISI marked PPE by their engaged Employees. An indicative list of ISI marked Personal Protective Equipment, is appended below for mandatory compliance by the vendors without any deviation:

LIST OF PPES (पी पी ई की सूची)

Note: Apart from the above-mentioned PPE, vendors may consider any other type of standardized PPE as per job requirement, in consultation with GRSE Safety Department.

(24) **ENVIRONMENT MANAGEMENT AND OCCUPATIONAL HEALTH & SAFETY(पर्यावरण प्रबंधन एवं व्यावसायिकस्वास्थ्य सुरक्षा):** - The vendor shall ensure compliance of Environment Management System (ISO14001:2014), Occupational Health & Safety (ISO 45001:2018) & Energy Management System (ISO 50001:2011) while carrying out their activity in the yard.

(25) **ENERGY CONSERVATION (ऊर्जा संरक्षण):** -

GRSE will provide power supply at free of cost for execution of job. The vendor should ensure that the power during execution of job shall be used in a very economic way to save energy as per Energy Management System of ISO 50001: 2011.

(26) **GUARANTEE FOR RAW MATERIAL(अनिर्मित सामग्री की गारंटी)** : This Clause will be applicable for Collection of Raw materials /Free Issue materials from GRSE for the jobs which are to be executed outside GRSE premises.

a) Raw materials will be required to collect from GRSE against submission of Bank Guarantee as per GRSE format for the equivalent value of material as specified in NIT/Purchase Order. Transportation of materials from GRSE to Sub-contractor's premises and transportation of finished materials from Sub-contractor's premises up to GRSE is the responsibility of the contractor or as specified in NIT.

b) Indemnity Bond affixing the Common Seal from the registered sub-contractors may be accepted in lieu of Bank Guarantee but it should be backed by Insurance Coverage with GRSE as the beneficiary on case to case basis. If the contractor is unable to take coverage, GRSE will cover such risk and cost of premium will be borne by the contractor/recovered from their dues.

c) Indemnity Bond has to be submitted as per GRSE Format on the non-judicial Stamp paper of value Rs. 100/- and to be Notarized if Common Seal is not applicable.

d) During collection of material, the Transporter of the Sub-Contractor has to submit L-R copy, failing which materials will not be issued to the Sub-Contractor.

e) For the jobs which are to be executed inside GRSE premises, submission of Bank Guarantee or Indemnity Bond for Collection Raw materials is not required.

(27) **MATERIAL RECONCILIATION STATEMENT (MRS) (सामग्री मिलान विवरण) :** -

(a) Firms are to furnish the material reconciliation statement (running MRS) to GRSE, for items supplied by GRSE for execution of a job at vendor's premises. Furnishing of MRS to be done immediately on delivery of the Finished item/Block but not later than 30 days of delivery of the finished item showing details of raw materials received, material actually consumed, excess material returned, wastage etc. This statement should be submitted with documentary evidence of material

issued/returned/wastage duly accepted by competent authority of GRSE and as per the GRSE format and filled up check list for MRS. Permissible variation in MRS is 1.5% of design weight of structure. MRS certification is to be completed by GRSE within 60 days of receipt of the same from vendors.

(b) Quantity of stiffeners used in transportation are to be mentioned in delivery challan

clearly indicating whether the stiffeners are: -

- i) Temporary stiffeners supplied by vendor.
- ii) Sections of ABS quality supplied by GRSE.

(c) While submitting MRS of Finished item/Block, copies of certified MRS of all previous Finished items/Blocks are to be enclosed. This will be called the final MRS.

(28) **INSURANCE (बीमा):** - In case the sub-contracted job has to be executed at contractor's premises, the Insurance has to be taken by the contractor with appropriate value coverage for the underlying risks (the beneficiary would be GRSE by endorsement) e.g. Loss due to following:

- (i) Fire as per AIFT including EQ, STFI at Contractors premises.
- (ii) Burglary including theft during Storage at Contractors premises.
- (iii) Marine transit to and fro as per ITC(A) including SRCC (on the basis of agreed valuation between GRSE & contractors).
- (iv) Loading & unloading including TP liability at all fabricator's premises.
- (v) Loss due to infidelity of contractors whilst in storage.
- (vi) Spoilage of material by contractors by any accidental reasons whatsoever.

If the contractor is unable to take coverage, GRSE will cover such risk and cost of premium will be borne by the contractor/recovered from their dues.

For the jobs which are to be executed inside GRSE premises, Insurance coverage will not be the responsibility of contractor.

(29) **SITE-INCHARGE/ LOG BOOK/ HINDRANCE & OTHER RECORDS (कार्यस्थान प्रभार/कार्यपंजी/बाधा एवं अन्य रिकार्ड):** -

- a) One fully responsible and Qualified Site-in-charge has to be posted at the site during progress of work.
- b) Attendance Register, Wage Register etc. are to be maintained daily for the particular job on board and to be shown as and when required.
- c) Details of technical personnel deployed for the job.
- d) Monthly progress report.
- e) Log book for re-work/ modification.
- f) Details of materials brought by vendor along with copies of challan.
- g) Proper record of hindrances is to be maintained by the sub-contractor for the purpose of timely removal of the hindrance and is to be put up for approval by

Project Leader/Site Engineer on weekly basis. A copy of the same would have to be enclosed while submitting any request for waiver of liquidated damages.

h) Sufficient Supervisory Staff should be provided by the contractor during execution of work and in case of any accident/ damage to GRSE properties, full responsibility will be attributed to the contractor and loss incurred will be recovered from the contractor.

(30) **WORKING HOURS (कार्य समय) :**

The Contractor's normal working hours shall be in between 8 AM-5:06 PM from Monday to Friday & from 8:00 AM to 1:00 PM on Saturday. 1st & 3rd Saturday is Non-Duty Saturday. Work may also be required to be carried out in shifts (A, B & G shifts) as per GRSE's requirement. Also, work may be required to be carried out on Sunday/Holiday or beyond schedule working hours as per requirement of GRSE and the Contractor will have to arrange for same as per SOTR/NIT Terms.

(31) **RISK PURCHASE (जोखिम खरीद):**

In case the progress of work is not satisfactory and the contractor fails to maintain the schedule, GRSE reserves the right to get the work done by alternative source at the risk and cost of sub-contractor.

GRSE shall be at liberty to purchase/obtain the service from the alternative source as it deems fit, to make good such default and or in the event of the contract being terminated, the balance of the remaining service to be delivered there under. Any excess over the job price / service rates, paid and incurred by GRSE, as the case may be, over the contract price shall be recoverable from the firm. To make good the recoverable excess amount paid, GRSE shall be at liberty to invoke Bank Guarantee and/or with other available dues of the firm.

(32) **INDIVIDUALITY OF THE CONTRACT (संविदा की वैयक्तिकता):**

This Contract should be treated as an individual contract and should not be related with other orders with GRSE in respect of progress of work or payment.

(33) **SECURITY OF INFORMATION (सूचना की गोपनीयता): -**

All documents and drawings of this project are of confidential in nature and should be used explicitly for the purpose for which they are provided. Drawings should not be copied and should be returned to GRSE on completion of work.

No information in respect of contracts/orders shall be released to the national or international media or any one not directly involved its execution without the express written approval of the Integrated Headquarters, MOD (NAVY). In the event of any breach of above provisions, the vendor would have to make good of any loss/ cost/ damage/ any other claim whatsoever preferred by anybody to GRSE in this respect.

Non-Disclosure Agreement (NDA) as specified in the NIT has to be submitted as per GRSE Format.

(34) **REGISTRATION OF NEW VENDOR (नए बिक्रेता का पंजीकरण):**

The contractor has to confirm if they are registered with GRSE and Indicate Vendor Code (5 digits) and Product Code group accordingly in their offer. If the contractor is not registered with GRSE, then documents required for provisional vendor registration has to be submitted to the Ordering Department. For Permanent Vendor Registration with GRSE, the contractor has to submit their application to GRSE Vendor Development Cell.

(35) **CONTRACT WORKMAN WAGE PAYMENT (संविदा कामगार का मजदूरी भुगतान): -**
Payment of wages to the contractor's employee/workmen should be made through individual bank account on monthly basis instead of cash payment. PF-UAN activation of all the contractor's employee/workmen is mandatory.

(36) **INSPECTION (निरीक्षण): -**

(i) Quality assurance authority: As per NIT/SOTR.

(ii) Inspection to be carried out stage wise by Quality Assurance Authority. On completion of work for any stage, vendor has to submit Inspection Offer to GRSE (Inspection Agency) for stage inspection. GRSE (Inspection Agency) shall co-ordinate with the Outside Inspection Authorities (as applicable) for carrying out inspection of completed job.

(iii) GRSE reserve the right to inspect all operations to be carried out by the contractor. Free access to the work site at all the time shall be ensured by contractor. The presence or absence of GRSE representative does not relieve contractor of the responsibility for quality control. The contractor shall provide all assistance for carrying out inspection of completed work.

(iv) Repeat inspection for any particular job is to be discouraged as far as possible. Hence the vendor should complete the job in all respect prior to submission of Inspection Offer to avoid reoffering. In case of repeat inspection happens for more than two occasions then the additional cost implication incurred by GRSE will be deducted from the bills of the vendor at actual. Number of occasions of repeat inspection for any particular job is to be indicated by GRSE in inspection note and same is to be incorporated in the work done certificate for deduction of additional cost implication for repeat inspection. Cost of deduction shall be calculated by Executing Dept., GRSE with the help of Finance Dept., GRSE.

(37) **CORRECTION OF ERRORS (त्रुटि सुधार):**

Bids determined to be responsive will be checked by GRSE for any arithmetic error. Errors will be corrected by GRSE as follows:

(i) **For Manual Tendering:** - NA

a) Where there is a discrepancy between the rates in figures and in words, the rates in words will govern.

b) Where there is a discrepancy between the unit rate and the line item total resulting from multiplying the unit rate by the quantity, the unit rate as quoted will govern.

(ii) For Tendering through NIC Portal: - NA

Where there is a discrepancy between the rates in html format and the attachment to price bid (if applicable), the rates in attachment to price bid will govern. In attachment to Price bid; if any discrepancy found between the unit rate and the line item total resulting from multiplying the unit rate by the quantity, the unit rate as quoted will be considered.

(iii) For Tendering through GeM Portal: -

Where there is a discrepancy between the total price quoted in GeM Portal and the attachment (i.e break up of quoted price in line with BOQ) to price offer, the total price quoted in GeM portal will govern. In attachment to the Price offer, if any discrepancy found between the unit rate and the line item total resulting from multiplying the unit rate by the quantity, the unit rate as quoted will be considered.

(38) **FORCE MAJEURE (अप्रत्याशित घटना) :**

In the event of contractor being unable to fulfil the obligation under the agreement owing to force majeure, such as War, Fire, Earthquake, Flood, Strike/ Lockout at GRSE premises where the contractor is working, the party affected shall not be held responsible for any failure or non-performance of the duties and obligations under the agreement, provided that all responsible efforts have been made to overcome the consequences of such failure, or non-performance. The time for performances of the contractual obligation shall then be extended by period not more than the duration of such events.

In the event of Force Majeure condition existing at contractor's site in GRSE Premises or CPT areas for GRSE work, GRSE is to be intimated with details of such happenings and cessations thereof, within 3 days. Force Majeure is to be limited to contractor's site in GRSE/CPT premises for GRSE's work only. Lock out/ Closure of contractor's factory premises or office or any other place outside GRSE/CPT/GRSE nominated place as indicated above cannot be considered as a Force Majeure condition under this contract.

(39) **TERMINATION OF CONTRACT (अनुबंध की समाप्ती):** In the event of non-performance or non-engagement of manpower for the execution of the job within the notice period, GRSE reserves the right to cancel the order in part or in full, and no compensation whatsoever will be entertained.

(40) **DAMAGE OF MATERIALS / EQUIPMENTS (सामग्री/उपकरण की छती):** The contractor will ensure that no damage is caused to the materials, equipment or any other property of GRSE due to negligence and / or any reason whatsoever by the contractor's personnel. The cost of such damage will be suitably recovered from contractor's bills.

(41) **OFFICE & STORAGE SPACE (कार्यालय एवं भंडारण स्थान):** The contractor will have to arrange their office & storage required for execution of job, for cumulative order value of Rs.75 lakhs and above, of their own. However, space for placing up to one container will be provided free of cost by GRSE. Container will have to be removed by the contractor within 03 months from the date of final settlement with GRSE. In

case of non-removal of container within specified period penalty as deemed fit will be imposed for the occupied area of GRSE.

(42) **ARBITRATION (मध्यस्थता): -**

- i. If at any time, before during or after the contract period, any unsettled claim, question, dispute or difference arises between the parties, upon or in relation to or in connection with or in any way touching or concerning this order, the same shall be settled/adjudicated through Arbitration to be conducted by a Sole Arbitrator, to be appointed by the parties on mutual consent, in accordance with the provisions of the Arbitration and Conciliation Act, 1996.
- ii. In the event the parties fail to mutually appoint a Sole Arbitrator within 30 days from the receipt of a request by one party from the other, then either of the parties may approach the Hon'ble High Court at Calcutta under the provisions of the Arbitration and Conciliation Act, 1996 for appointment of a Sole Arbitrator by the Hon'ble Court.
- iii. Such arbitration shall, in all respects, be conducted in accordance with the provisions of the Arbitration and Conciliation Act, 1996 and the rules framed there under or any statutory modification or re-enactment thereof for the time being in force.
- iv. The Award of the Sole Arbitrator shall be final, conclusive and binding upon the Parties.
- v. In the event of the death or resignation or incapacity or whatsoever of the said Sole Arbitrator if appointed by the parties mutually the said parties may again appoint a suitable Substitute Arbitrator in place of the erstwhile Sole Arbitrator to continue with the proceedings. In the event of appointment of the Sole Arbitrator by the Hon'ble High court at Calcutta on death or resignation or incapacity or whatsoever of the said Sole Arbitrator, either of the parties in this behalf, may make an application to the Hon'ble High court at Calcutta for appointment of a Substitute Arbitrator and the Hon'ble Court may pass such orders as it deems fit and proper.
- vi. Also, in the event an Arbitration award is set aside by a competent court the parties may appoint a Sole Arbitrator mutually or on failing to appoint a Sole Arbitrator mutually within the statutory period then either of the parties may file an application before the Hon'ble High Court at Calcutta under the provisions of the Arbitration and Conciliation Act, 1996 for appointment of a Sole Arbitrator by the Hon'ble Court in accordance with the provisions of the Arbitration & Conciliation Act.
- vii. The cost of the arbitration, fees of the arbitrator, remuneration of the stenographer and clerk, stamp paper etc. shall be shared equally by the parties, unless otherwise directed by the Sole Arbitrator. The venue of arbitration shall be at Kolkata and unless otherwise decided by the parties or by the Sole Arbitrator himself, the venue shall be the premises of Garden Reach Shipbuilders & Engineers Ltd. located at 43/46, Garden Reach Road, Kolkata 700 024.

viii. The language of the proceeding shall be in English.

(43) **JURISDICTION (न्याय अधिकार):** Litigation, if any, pertaining to this contract will come under the jurisdiction of High Court at Kolkata.

- i) All contracts shall be deemed to have been wholly made in Kolkata and all claims there under are payable in Kolkata City and it is the distinct condition of the order that no suit or action for the purpose of enforcing any claim in respect of the order shall be instituted in any Court other than that situated in Kolkata City, West Bengal State, India.
 - ii) The Firm is warranted that all service rendered by them shall conform to applicable city, states & central laws, ordinances and regulations and the said Firm shall indemnify / defend / relieve GRSE harmless, from / of against loss, cost of damage, by reason or any actual or alleged violation thereof.
 - iii) GRSE shall not be liable under the workmen's compensation Act of 1923; in case any employee or workmen receives injury while actually serving his employer in connection with the latter's work inside the compound of GRSE Ltd.
 - iv) All existing applicable Laws such as ESI, PF, SERVICE, CONTRACT LABOUR, CHILD LABOUR etc. as applicable, shall be binding for the contract.
1. For any discrepancy between SOTR/NIT (Notice Inviting Tender) and STAC, SOTR/NIT statement may be taken as final.
 2. Clarification required, if any, regarding Tender Document, should be got resolved by contacting competent authority of GRSE prior to submission of bid.

INTEGRITY PACT

Between

M/s Garden Reach Shipbuilders & Engineers Limited (GRSE) hereinafter referred to as "The Principal"

and

..... hereinafter referred to as "the Bidder/Contractor"

Preamble

The Principal intends to award, under laid down organizational procedures, contract/s for "Name of the job:-----". The principal values full compliance with all relevant laws of the land, rules, regulations, economic use of resources and of fairness /transparency in its relations with its Bidder(s)/ or Contractors (s).

In order to achieve these goals, the principal will appoint an Independent External Monitor (IEM), who will monitor the tender process and the execution of the contract for compliance with the principals mentioned above.

Section 1- Commitments of the principal

[1] The Principal commits itself to take all measures necessary to prevent corruption and to observe the following principles:-

- a. No employee of the principal, personally or through family members, will in connection with the tender for, or the execution of a contract, demand, take a promise for or accept for self or third person, any material or immaterial benefit which the person is not legally entitled to.
- b. The Principal will, during the tender process treat all Bidder(s) with equity and reason. The principal will in particular, before and during the tender process, provided to all Bidder(s) the same information and will not provide to any Bidder(s) confidential /additional information through which the Bidder(s) could obtain an advantage in relation to the tender process or the contact execution.
- c. The principal will exclude from the process all known prejudiced persons.

[2] If the principal obtains information on the conduct of any of its employees which is a criminal offence under the IPC/PC Act, or if there be a substantive suspicion in this regard, the principal will inform the Chief Vigilance Officer and in addition can initiate disciplinary actions.

Section 2- Commitments of the Bidder(s)/Contractor(s)

[1] The Bidder(s)/Contractor(s) commit himself to take all measures necessary to prevent corruption. He commits himself to observe the following principles during his participation in the tender process and during the contract execution.

a. The Bidder(s)/ Contractor(s) will not, directly or through any other person or firm, offer, promise or give to any of the principal's employees involved in the tender process or the execution of the contract or to any third person any material or other benefit which he/she is not legally entitled to in order to obtain in exchange any advantage of any kind whatsoever during the tender process or during the execution of the contract.

b. The Bidder(s)/Contractor(s) will not enter with other Bidders into any undisclosed agreement or understanding, whether formal or informal. This applies in particular to prices, specifications, certifications, subsidiary contracts, submission or non-submission of bids or any other actions to restrict competitiveness or to introduce cartelization in the bidding process.

c. The Bidder(s)/Contractor(s) will not commit any offence under the relevant IPC/PC Act, further the Bidder(s)/Contractor(s) will not use improperly, for purpose of competition or personal gain, or pass on to others, any information or document provided by the principal as part of the business relationship, regarding plans, technical proposals and business details, including information contained or transmitted electronically.

d. The Bidder(s)/Contractor(s) of foreign origin shall disclose the name and address of the Agents/representatives in India, if any. Similarly the Bidder(s) / Contractor(s) of Indian Nationality shall furnish the name and address of the foreign particulars, if any. Further details as mentioned in the "Guidelines on Indian agents of Foreign suppliers" shall be disclosed by the Bidder(s)/Contractor(s). Further as mentioned in the Guidelines all the payments made to the Indian agent/representative have to be in Indian Rupees only, copy of the "Guidelines on Indian agent of foreign supplier" is annexed and marked as annex.

e. The Bidder(s)/Contractor(S) will, when presenting his bid, disclose any and all payments he has made, is committed to or intends to make to agents, brokers or any other intermediaries in connection with the award of the contract.

[2] The Bidders(s)/ Contractor(s) will not instigate third persons to commit offences, outline above or be an accessory to such offence.

Section 3- Disqualification from tender process and exclusion from future contracts.

If the Bidder(s)/Contractor(s) before award or during execution has committed a transgression through a violation of Section 2, above or in any other form such as to put his reliability or credibility in question, the principal is entitled to disqualify the Bidders(s)/ Contractor(s) from the tender process or take action as per the extant procedure of the company.

Section 4- Compensation for Damages.

- 1) If the principal has disqualified the Bidder(s) from the tender process prior to the award according to section 3, the principal is entitled to demand and recover the damages equivalent to earnest Money deposit/Bid security.
- 2) If the Principal has terminated the contract according to section 3, or if the principal is entitled to terminate the contract according to section 3, the Principal shall be entitled to demand and recover from the contractor liquidated damages of the contract value or the amount equivalent to Performance Bank Guarantee.

Section 5- Previous Transgression

- 1) The Bidder declares that no previous transgressions occurred in the last 3 years with any other company in any country conforming to the anti corruption approach or with any other Public Sector Enterprise in India that could justify his exclusion from the tender process.
- 2) If the Bidder makes incorrect statement on this subject he can be disqualified from the tender process or action can be taken as per the procedure mentioned in "Guidelines on Banning of business dealing"

Section 6- Equal treatment of all Bidders/Contractors/Sub-contractors.

- 1) The Bidder(s)/Contractor(s) undertake(s) to demand from all sub-contractors a commitment in conformity with this integrity pact, and to submit it to the principal before contract signing.
- 2) The principal will enter into agreements with identical conditions as this one with all Bidders, Contractors and Sub-Contractors.
- 3) The Principal will disqualify from the tender process all bidders who do not sign this pact or violates its provisions.

Section 7- Criminal charges against violating Bidder(s) Contractor(s)/Sub-Contractor(s)

If the principal obtains knowledge of conduct of a Bidder, contractor or subcontractor, or of an employee or a representative or an associate of a Bidder, Contractor or Sub contractor which constitutes corruption, or if the principal has substantive suspicion in this regard, the principal will inform the same to the Chief Vigilance Officer.

Section 8- Independent External Monitor/Monitors

- 1) The Principal appoints competent and credible Independent External Monitor for this pact. The task of the Monitor is to review independently and objectively, whether and to what extent the parties comply with the obligations under this agreement.
- 2) The Monitor is not subject to instructions by the representative of the parties and perform his functions neutrally and independently. He reports to the Chairman GRSE.
- 3) The Bidder(s)/Contractor (s) accepts that the Monitor has the right to access without restriction to all project documentation of the principal including that provided by the contractor. The contractor will also grant the Monitor, upon his request and

demonstration of a valid interest, unrestricted and unconditional access to his project documentation. The same is applicable to subcontractors. The Monitor is under contractual obligation to treat the information and documents of the Bidder(s)/ Contractor(s) /Subcontractor(s) with confidentiality.

4) The Principal will provide to the Monitor sufficient information about all meeting among the parties related to the project provided such meetings could have an impact on the contractual relations between the principal and the contractor, The parties offer to the Monitor the option to participate in such meetings.

5) As soon as the Monitor notices, or believes to notice, a violation of this agreement, he will so inform the management of the principal and request the management to discontinue or take corrective action, or to take other relevant action. The Monitor can in this regard submit non-binding recommendations. Beyond this the Monitor has no right to demand from the parties that they act in a specific manner, refrain from action or tolerate action.

6) The Monitor will submit a written report to the Chairman, GRSE within 8 to 10 weeks from the date of reference or intimation to him by the principal and should the occasion arise, submit proposals for correcting problematic situations.

7) Monitor shall be entitled to compensation on the same terms as being extended to/provided to Independent Directors on the GRSE Board.

8) If the Monitor has reported to the Chairman GRSE a substantiated suspicion of an offence under relevant IPC/PC act, and the Chairman GRSE has not, within the reasonable time taken visible action to proceed against such offence or reported it to the Chief Vigilance Officer, the Monitor may also transmit this information directly to the Central Vigilance Commissioner.

9) The word `Monitor' would include both Singular and plural.

Section 9- Pact Duration:

This pact begins, when both parties have legally signed it. It expires for the contractor 18 months after the last payment under the contract, and for all other Bidders 6 months after the contract has been awarded.

If any claim is made/lodged during this time, the same shall be binding and continue to be valid despite the lapse of this pact as specified above, unless it is discharged/determined by Chairman of GRSE.

Section 10- Other provisions:

1) This agreement is subject to Indian Law, place of performance and jurisdiction is the Registered Office of the principal i.e. Kolkata.

2) Changes and supplements as well as termination notices need to be made in writing. Side agreements have not been made.

3) If the Contractor is a partnership or a consortium, this agreement must be signed by all partners or consortium members.

4) Should one or several provisions of this agreement turn out to be invalid, the remainder of this agreement remains valid. In this case, the parties will strive to come to an agreement to their original intentions.

(For & On behalf of the principal)

(For & On behalf of the Bidder/Contractor)

Place

Place

Date

Date

Witness 1
(Name & Address)

Witness 2
(Name & Address)

ANNEXURE - 4

FORMAT FOR EXECUTED RELEVANT JOBS TO JUSTIFY TECHNICAL ELIGIBILITY

1. **Name of the Bidder:**

2. **Job Description:**

3. **Tender Reference:**

Details of Executed relevant jobs:

Sl. No	Description of Executed relevant jobs	Order No. & Date (Supporting soft or, hard copy to be submitted)	Start & Completion date as per Order	Actual start date	Actual Completion Date	Order placed by	Value of Purchase order	Work completion certificate Ref. No. & date (Supporting soft or, hard copy to be submitted)
1								
2								
3								
4								
5								

Note: Please add additional pages if required

(Signature of Authorized Representative)

Date:

Name:

Designation:

FORMAT ON FINANCIAL ELIGIBILITY CRITERIA

(To be submitted on Company's letter head)

1. **Name of the Bidder:**

2. **Job Description:**

3. **Tender Reference:**

A. Financial Data for evaluating Financial Eligibility :

SL. No.	Financial Years	Turn Over (Rs. In Lakhs)
1	2022-23	
2	2021-22	
3	2020-21	

B. Detail of Solvency certificate:

Reference no. of certificate	Name of Bank, Branch	Amount of Solvency (Rs.)

(Signature of Authorized Representative)

Date:

Name:

Designation:

Note: i) Audited reports for above FY to be submitted as supporting documents.

ii) Banker's letter confirming solvency to be submitted as detailed in Article-19

SELF-CERTIFICATION FOR DECLARATION REGARDING BLACKLISTING/ TENDER HOLIDAY

(To be submitted in Company's Letterhead)

- A. Name of the Bidder: _____ Date: _____
- B. Job Description: _____
- C. GeM Tender/Bid Reference: _____

Dear Sir,

1. I / We, Proprietor / Partner(s) / Director(s) of M/s. _____ hereby declare that our firm / company namely M/s. _____ have neither been blacklisted nor have received any tender holiday by any PSUs/Central & State Govt. Organizations or any other Government / Quasi Government Organizations during last 03 (three) years ending on **31-May-2024** from taking part in Government tenders.

OR

I / We Proprietor/ Partner(s) / Director(s) of M/s. _____ hereby declare that our firm / company namely M/s. _____ has received tender holiday from M/s. _____ *(name of PSUs/Central & State Govt. Organizations or any other Government / Quasi Government Organizations)* from taking part in Government tenders for a period of _____ months w.e.f. _____ to _____ *(date)*. The period is over on _____ *(date)* and now our firm/company is entitled to take part in Government tenders. (Relevant withdrawal/revocation document is attached).

2. In case the above information are found inappropriate, I / We are fully aware that the offer submitted by our firm / contract awarded to our firm/company namely M/s. _____ will be rejected / cancelled by M/s GRSE, and EMD / SD shall be forfeited and appropriate action will be taken in accordance with the vendor policy of GRSE.

Signature

Name

Designation:

Name & address of the firm:

Date:

with Seal

Signature of Bidder

**CHECK LIST OF STATUTORY RESPONSIBILITY OF CONTRACTOR
THE CONTRACT LABOUR (R& A), ACT, 1970 AND CENTRAL RULES, 1971**

SL. NO.	NATURE OF STATUTORY REQUIREMENTS	FORM NO.	RESPONSIBILITY	REMARKS
01	Labour License	Form –II	Contractor	Contractors engaging 20 or more contract labours would apply for obtaining labour license (in triplicate) to the ALC (C), Kolkata. A copy of the license should be submitted to concerned Unit HR Department. <i>Note:</i> The Contractor cannot deploy more than the number of workmen mentioned in the license on any day.
02	Renewal of labour license	Form –II	Contractor	The contractor shall apply to the ALC(C), Kolkata for renewal of license at least 30 days prior to its expiry. A copy of the acknowledgement / renewed license should be submitted to concerned Unit HR Department.
03	Notice for commencement / completion of work	Form-VII	Contractor / Principal Employer	The contractor shall submit Form – VII to the Inspector / Labour Enforcement Officer (C), Kolkata within 15 days intimating the actual date of commencement / completion of the work. The receipted copy of Form – VII should be submitted to concerned Unit HR Department.
MAINTENANCE OF REGISTERS				
04	Employee Register	FORM – A	Contractor	Comprising of personal details like name, father's name, DOB, Address etc. of the workmen engaged by the contractor.
05	Wages Payment Register	FORM – B	Contractor	Comprising of current rate of minimum wages, employees PF & ESI contribution and other allowances, if any.
06	Register of Loan / Recoveries / Fines etc.	FORM – C	Contractor	To maintain record of loans, fines and advances given, if any and monthly record of recoveries.
07	Attendance Registers	FORM – D	Contractor	Data of daily attendance of each workmen engaged by the contractor indicating their in and out time.

SL. NO.	NATURE OF STATUTORY REQUIREMENTS	FORM NO.	RESPONSIBILITY	REMARKS
08	Employment Card	Form – XII	Contractor	Every contractor shall issue employment card / appointment letter to their contract workers within 03 days from their date of employment.
09	Service Certificate	Form – VIII	Contractor	To be issued by the contractor upon termination of employment / completion of work etc.
10	Wage-slip	Form – XIX	Contractor	Contractors shall issue wage-slip to their workmen at least 01 day prior to disbursement of wages.
11	Annual Return	Online Submission	Contractor	Every Contractors shall prepare Annual Return for the previous year which is submitted online by the Contractors' in <i>Shram Suvidha</i> Portal to the Registering Officer within 31st Jan of the following year.

**CHECK LIST OF STATUTORY RESPONSIBILITY OF CONTRACTOR
COMPLIANCE OF OTHER STATUES FOR ENGAGEMENT OF CONTRACTORS' WORKMEN**

Sl. No.	Relevant Statues	Responsibility	Compliances to be ensured as per the Statute
01	The Factories Act, 1948 & West Bengal Factories Rules, 1958	Contractor	<p>1. <u>Leave with Wages</u>: Every worker who has worked for a period of 240 days or more is entitled to get leave with wages to be calculated one day for every 20 days of work performed by him.</p> <p>2. <u>Payment of Overtime</u>: Where a worker has worked for more than 09 hours in any day or for more than 48 hours in a week, he shall, in respect of overtime work, be entitled to wages twice the hourly rate.</p> <p>3. <u>Hours of Work</u>: The total nos. of hours of work in a week, including overtime, shall not exceed sixty.</p> <p>4. <u>Hours of Overtime</u>: The total hours of overtime shall not exceed fifty in any quarter i.e. during three consecutive months for any worker.</p>
02	Payment of Wages Act, 1936	Contractor	Contractors (employer) engaging less than 1,000 persons have to pay wages before expiry of the 7th day after the last day of wage period.
03	The Minimum Wages Act, 1948	Contractor	Contractors (employer) shall pay minimum wages to every worker as per the Central rates circulated by the Management from time to time.
04	The EPF & MP Act, 1952	Contractor	<p>1. Every contractor shall obtain the following before commencement of work:</p> <p>(a) PF Code No. of the firm.</p> <p>(b) PF UAN i.r.o of the workmen engaged by him.</p> <p>(c) Ensure submission of nominee and dependent details while applying for UAN of workmen.</p>
		Contractor	<p>2. Every contractor shall contribute towards PF @ 12% of the monthly wages of each workman as employer's share and recover 12% of monthly wages from each employee, as employees share and thereafter remit the entire amount to EPFO i.r.o every workman engaged by him. The contribution for the preceding month should be remitted prior to expiry of the 15th day of the following month. Contractors (Employers) are also required to bear the administrative charges as applicable.</p>

Sl. No.	Relevant Statutes	Responsibility	Compliances to be ensured as per the Statute
05	The ESI Act, 1948	Contractor	1. Every contractor shall obtain the following: a) ESI Code No. of the firm b) ESI code no. i.r.o of the workmen engaged by him c) Ensure submission of nominee and dependent details while applying for ESI TIC (E-Pehchan Card).
		Contractor	2. Every contractor shall remit ESI contribution (employers' share @ 3.25% and employees' share @ 0.75%) i.r.o every workman engaged by him for the preceding month prior to expiry of the 15th day of the following month.
06	The Payment of Bonus Act 1965 & Rules	Contractor	1. Contractors shall pay annual bonus to their workmen (Contract Labour) drawing wages below and upto Rs. 21,000/- per month. Bonus will be payable minimum @ 8.33% and maximum @ 20% of annual wages.
		Contractor	2. Register in Form - C format {Rule 4(b)} of 'The Payment of Bonus Act, 1965' is to be maintained by the contractor for submission of Annual Return as per the Act.

**RESPONSIBILITIES OF CONTRACTORS OVER AND
ABOVE THE STATUTORY REQUIREMENTS**

- (i) Contractors shall take all necessary steps for disbursement of wages through bank-transfer and issue a payment notice at least 02 days prior to such bank-transfer for information of respective unit HR Dept. as well his workers. (should be incorporated in the contract document in the Payment Terms).
- (ii) All contractors should obtain labour-licenses prior to commencement of work. Principal Employer shall not allow any contractor without license.
- (iii) All outsourced jobs are required to be supervised by a Supervisor duly appointed by the Contractor. The contractor should declare the name and contact number of the supervisor(s) against each P.O before commencement of work and submit the details of the supervisor(s) to the respective unit HR Department. He should keep adequate nos. of supervisors to supervise and co-ordinate the execution of job by contract labours. (The principal employer must check that the name and number of the supervisor which has been provided by the contractor, whether the same person is coming as the said supervisor).
- (iv) The supervisor's name should not be mentioned in the employee register as he is not a contract labour.
- (v) Supervisor of concerned contractor should be present in the work-site where the contract labours of the concerned contractor are supposed to work. To ensure the presence of the supervisor, their attendance may be recorded by the user department on daily basis.
- (vi) Contractor should mention the name of his Supervisor / agent / manager in Form-II which is to be submitted to ALC (C) for obtaining labour license.
- (vii) The supervisor should maintain the attendance register of their contract labours (Form-D) which may be randomly checked by the Officers of the user department. This attendance register will be submitted by the contractors on monthly basis along with the wages-payment registers to the respective unit HR Depts. for obtaining certification of payment of wages to each contractor labour based on their daily / monthly attendances.
- (viii) Contractors must submit details of their firms in the Appendix B1 format prior to commencement of work. They must also submit details of their contract labours in B2 formats for making new gate-passes for the purpose of entry / exit prior to the engagement of such contract labour.

CHECK LIST FOR BILL SUBMISSION - for Service Contracts				
A.	GENERAL PARTICULARS: (to be checked and submitted by Contractor/Vendor)			
A.1	BTN (as per BTS System):-			
A.2	Invoice No and date / E-Invoice No. & Date (if applicable for the vendor) (Original & in triplicate)			
A.3	PO Number			
A.4	Name of Vendor			
A.5	Location of work :	MW / RBD/ FOJ/ TU / 61Park/Vendor's premises		
I. For RA Bill (Running/Progressive bill) (Put ✓ Mark)		YES	NO	NA
A.6	PO Number and date verified with Invoice:			
A.7	Vendor Name & Address in Invoice verified with Purchase Order:			
A.8	Vendor Code as in PO verified with Invoice:			
A.9	Original certified WDC enclosed :			
A.10	Whether WDC is Certified by the Authorized Person as per PO / SOTR with Rubber Stamp			
A.12	HSN/SAC code is as per PO			
A.13	GSTIN No. is as per PO			
A.14	GST % is as per PO			
A.15	Security Deposit (SD) submitted as per PO			
A.16	PBG of equivalent amount submitted, as per PO			
A.17	Compliance of Statutory Liabilities of labour as per PO			
II. Applicable for Final/Balance Bill (Put ✓ Mark)				
A.20	Certified Job Completion Certificate (JCC) enclosed			
A.21	MRS as per PO terms enclosed (If applicable)			
A.22	Guarantee Period (GP) expired as per PO term			
A.23	PBG of equivalent amount submitted, if GP is not over (If Yes, copy to enclose with the bill)			

Signature of Vendor's representative
with Seal/Stamp

Note: Transaction fee of Rs. 500.00 for first return & Rs. 1000.00 for subsequent return of bill with inappropriate documents will be charged.

CHECK LIST FOR BILL SUBMISSION - for Service Contracts**For GRSE Use Only**

B.	To be checked and verified by Bill certifying authority (Put ✓ Mark)	YES	NO	NA
B.1	Whether Bill has been forwarded through BTS			
B.2	Whether WDC is Certified by the Authorized Person as per PO / SOTR with Rubber Stamp			
B.3	Job starting & Completion Date (Schedule & Actual) indicated in WDC			
B.4	Certification of Penalty/ Recovery from bill indicated in WDC, if applicable			
B.5	Whether Bill is Certified by the Authorized Person as per PO / SOTR with Rubber Stamp			
B.6	Certification of Penalty/ Recovery from bill as per WDC, if applicable			
B.7	Service Entry Sheet(SES)/GR in line with WDC, PO & Invoice			
	For Final/Balance Bill (Put ✓ Mark)			
B.8	Certified MRS copy as per PO terms enclosed (If applicable)			
B.9	Guarantee Period (GP) expired as per PO term and JCC			
B.10	PBG copy of equivalent amount till GP validity enclosed(if GP is not over)			

Signature of GRSE Bill Certifying Authority
with Designation